

# UTILITY BRUSH TRUCK

TRI-COUNTY FIRE PROTECTION DISTRICT / PLYMOUTH, ILLINOIS



# ALEXIS



THANK YOU TO THE TRI-COUNTY FIRE PROTECTION DISTRICT FOR THE PURCHASE OF THIS UNIT.

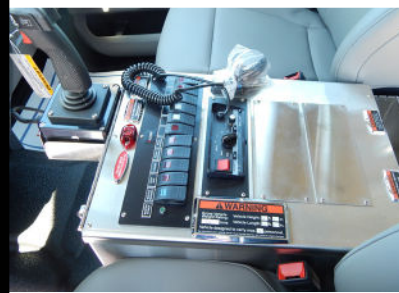

## TECHNICAL SPECIFICATIONS

- Ford F-550 4x4 Crew Cab Chassis
- 7.3L 350-HP V8 Gas Engine
- TorqShift 10-Speed Automatic Transmission
- Heavy Duty Aluminum Body & Subframe
- N-FAB Podium Black Nerf Bars
- Ranch Hand Legend Brush Guard
- Darley 2BE Direct Drive Pump w/ Honda 20-HP Engine
- 300-Gallon Poly Tank w/ 10-Gallon Foam Tank
- Two (2) 1" Discharges w/ Forestry Hose, Rear
- One (1) 2 1/2" Discharge, Rear
- One (1) 1 1/2" Discharge, Rear
- Trident Foamate Class A Around-the-Pump Foam System
- Akron 3462 Forestry Monitor, Front
- Hannay 1" Booster Reel, Right Side Rear
- Treadplate Hose Tray, Left Side Compartment Top
- Backboard Storage Compartment, Right Side Compartment Top
- Floor Mounted Console for Emergency Switches w/ Map/Binder Storage
- Progressive Dynamics Battery Charger
- Kussmaul Super Auto Eject 120V Shoreline Connection
- Whelen LED Warning Light Package
- Whelen Electronic Siren w/ 100-watt Speaker
- Whelen Pioneer LED Telescopic Light, Right Side Front of Body
- FRC VantagePoint LED Remote Controlled Light, Headache Rack
- Diamond Grade Chevron Striping, Rear
- 7' 10" Overall Height
- 24' 4" Overall Length
- 179" Wheelbase
- 60" Cab to Axle
- 7,500 FAWR
- 14,706 RAWR
- 19,500 GVWR

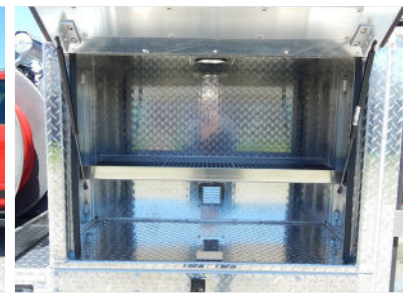

To view more photos and download spec sheet, please visit us at [AlexisFire.com](http://AlexisFire.com).

CUSTOMER APPROVAL SIGNATURE: \_\_\_\_\_ DATE: \_\_\_\_\_

TR-1CO-0001

IN THE EVENT THERE ARE DISCREPANCIES BETWEEN THE DRAWING AND THE SPECIFICATIONS THE SPECIFICATIONS SHALL PREVAIL.

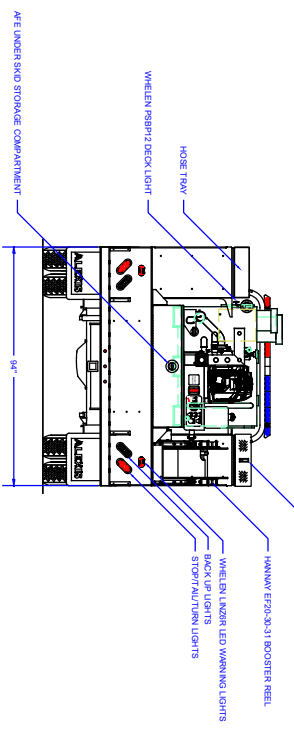
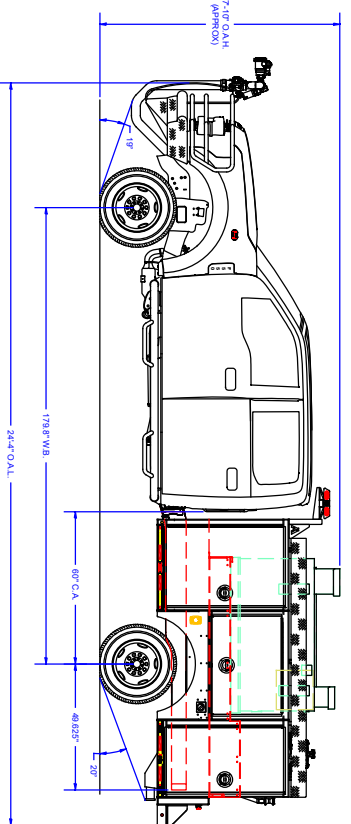
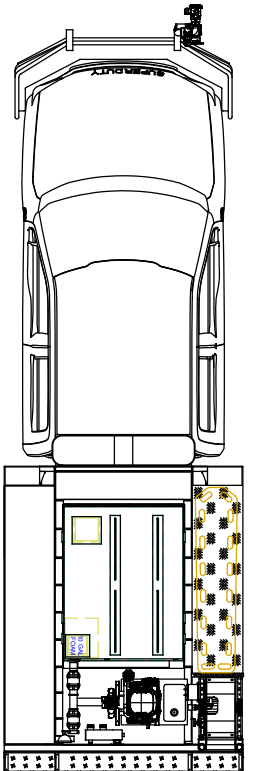
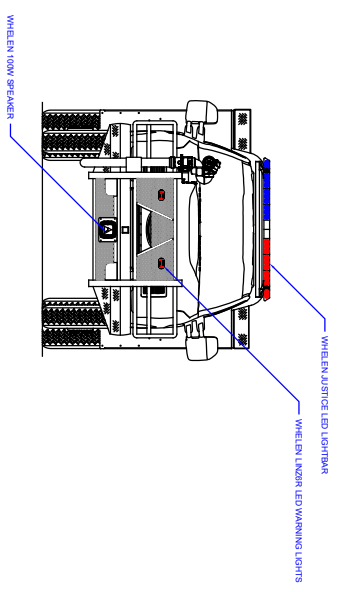
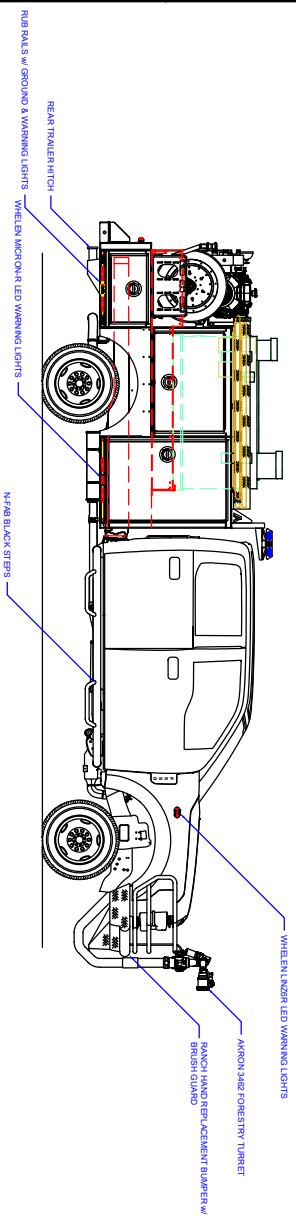

**COMPARTMENT DIMENSIONS**

COMP #	DOOR OPENING SIZES
L1 & R1	28" WIDE X 24" HIGH X 17" DEEP
L2 & R2	35" WIDE X 26" HIGH X 17" DEEP
L3	25" WIDE X 44" HIGH X 17" DEEP
R3	25" WIDE X 17" HIGH X 17" DEEP

**ALEXIS FIRE EQUIPMENT CO.**  
 P.O. BOX 669, ALEXIS, ILLINOIS 62412  
**UTILITY BRUSH TRUCK**  
 TRI COUNTY FPD  
 PLYMOUTH, IL

UNLESS OTHERWISE SPECIFIED:  
 DIMENSIONS ARE IN INCHES AND DECIMALS THEREAFTER.  
 DIMENSIONS ARE NOT DIMENSIONAL.

REVISION HISTORY	DATE	BY	DESCRIPTION
1	09/08/20	J. HENNING	ISSUE FOR PRODUCTION
2			

PUMP INFO:	APPARATUS TYPE:	MATERIAL:
Control Location: Rear	UTILITY FLATBED	Aluminum
Pump Drive: None	Chassis: Ford 4-Door	
Pump Make: SMI-Gas	Tank Capacity: 300	
Pump Model: OTHER		
Pump GPM:		