

CUSTOMER APPROVAL SIGNATURE:

DATE:

ALEXIS-0001

IN THE EVENT THERE ARE DISCREPANCIES BETWEEN THE DRAWING AND THE SPECIFICATIONS, THE SPECIFICATIONS SHALL PREVAIL.

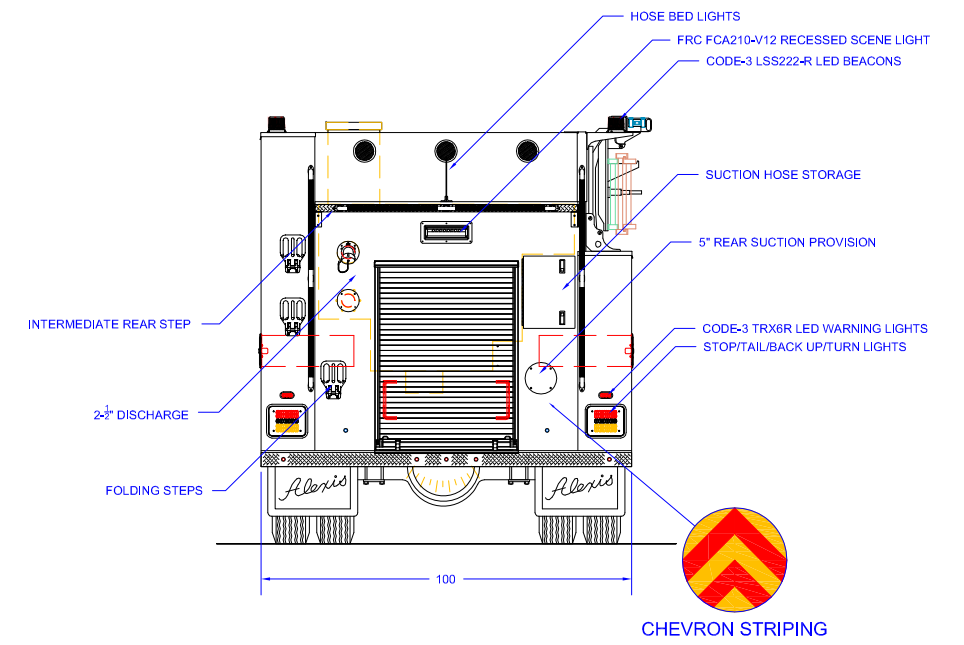
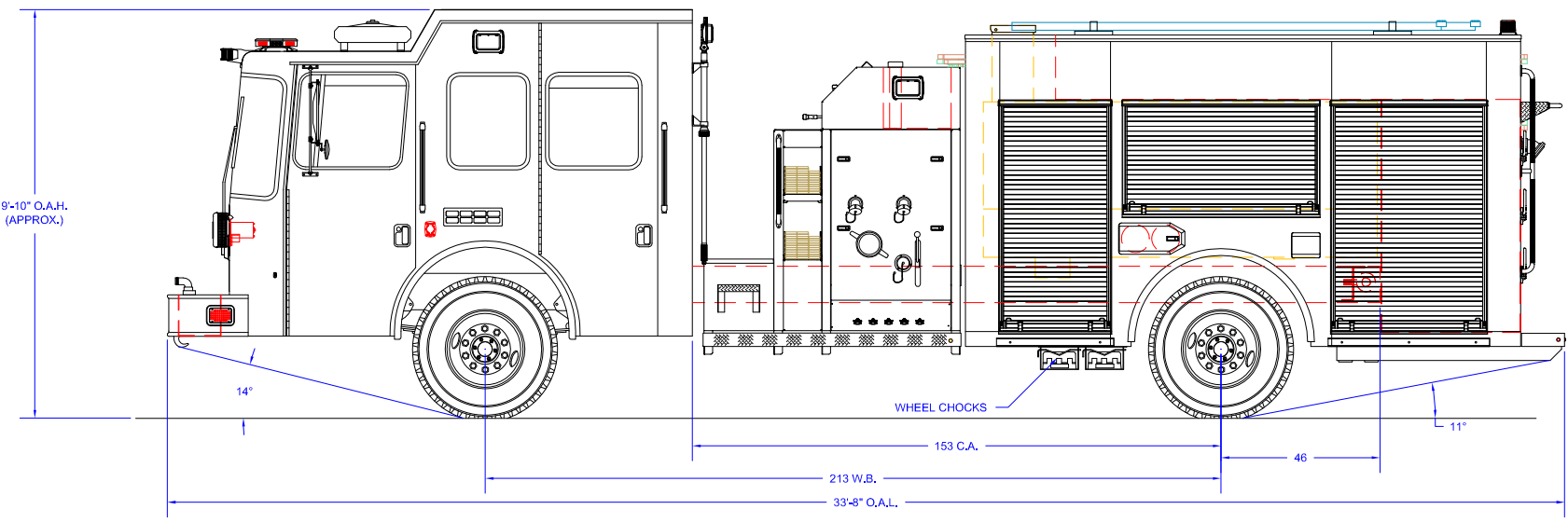
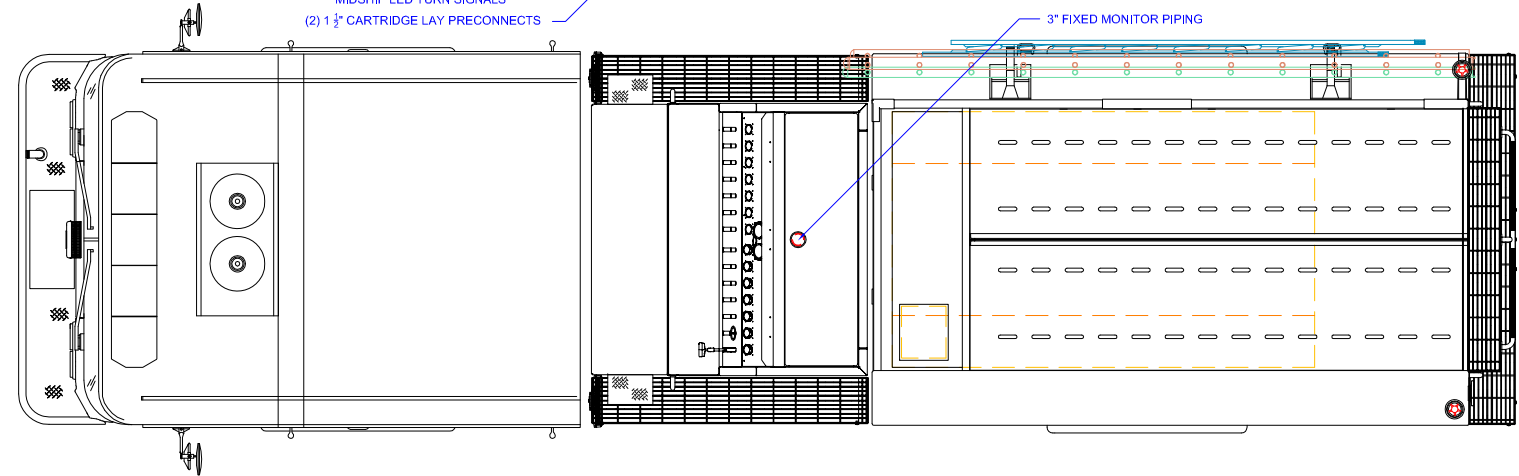
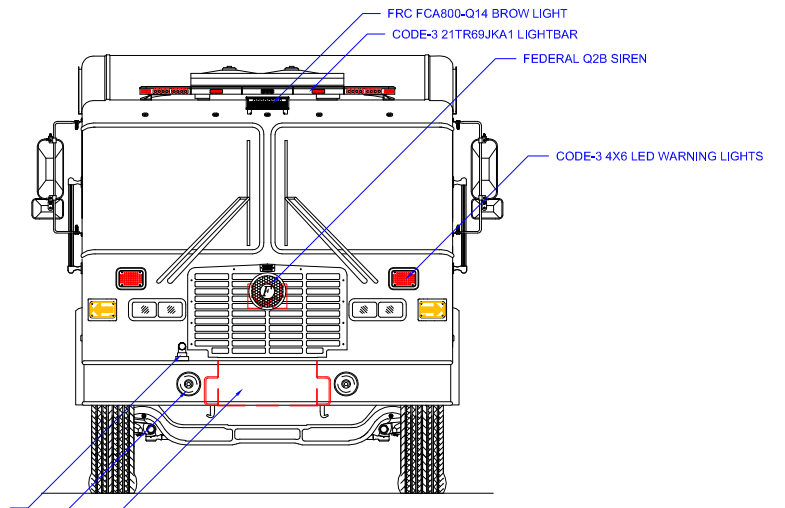
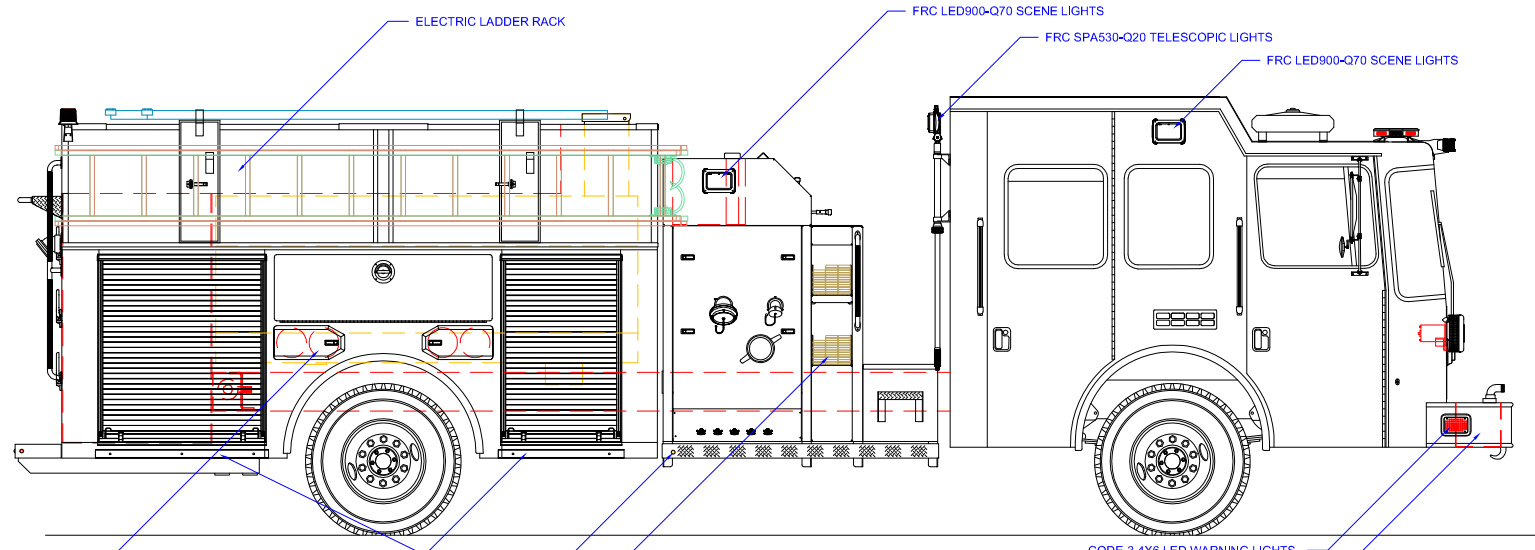

| REVISION HISTORY | | | |
|------------------|-------------|------|-----|
| REV | DESCRIPTION | DATE | DWN |
| | | | |

| | |
|--------------------------------|----------------------------------|
| Pump Info: | |
| Control Location: Top | Apparatus Type: Pumper |
| Pump Drive: Split Shaft | Chassis: HME 60 - BOC |
| Pump Make: Darley | Tank Capacity: 1000 |
| Pump Model: PSM | |
| Pump GPM: 1500 | Material: Stainless Steel |

| COMPARTMENT DIMENSIONS | |
|------------------------|------------------------------------|
| COMP # | DOOR OPENING SIZES |
| L1 | 30" WIDE X 61" HIGH X 12"/26" DEEP |
| L2 | 54" WIDE X 27" HIGH X 12" DEEP |
| L3 | 42" WIDE X 61" HIGH X 12"/26" DEEP |
| R1 | 30" WIDE X 45" HIGH X 12"/26" DEEP |
| R2 | 56" WIDE X 15" HIGH X 12" DEEP |
| R3 | 42" WIDE X 45" HIGH X 12"/26" DEEP |
| REAR | 36" WIDE X 44" HIGH X 37" DEEP |

UNLESS OTHERWISE SPECIFIED DIMENSIONS ARE IN INCHES TOLERANCES ARE NOT CUMULATIVE

DECIMAL ± 0.062 ANGULAR ± 0.5°
 FRACTIONAL ± 1/16 METRIC ± 1.6 mm

The copyright of this drawing and design and the right of reproduction there is vested in and belongs to Alexis Fire Equipment Co.

DRAWN: M.TINKHAM 3/12/15
 MATERIAL:

Alexis FIRE EQUIPMENT CO.
 P.O. BOX 549, ALEXIS, ILLINOIS 61412

PUMPER
 ALEXIS FIRE EQUIPMENT COMPANY
 ALEXIS, ILLINOIS

SIZE: D SCALE: 1/2"=1'
 DWG NO: P-V51
 CONTRACT #: 2315 SHEET 1 OF 2

CUSTOMER APPROVAL SIGNATURE:

DATE:

ALEXIS-0001

IN THE EVENT THERE ARE DISCREPANCIES BETWEEN THE DRAWING AND THE SPECIFICATIONS, THE SPECIFICATIONS SHALL PREVAIL.

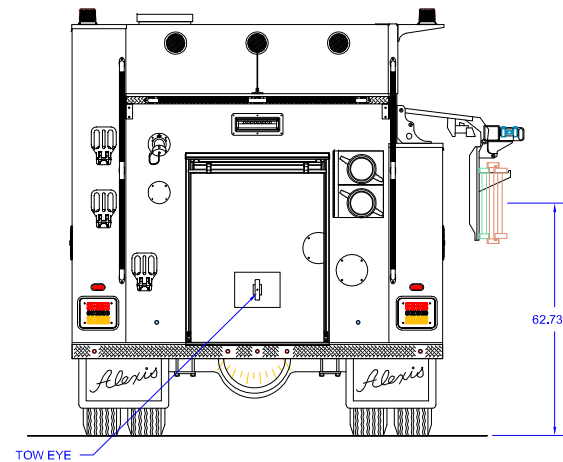
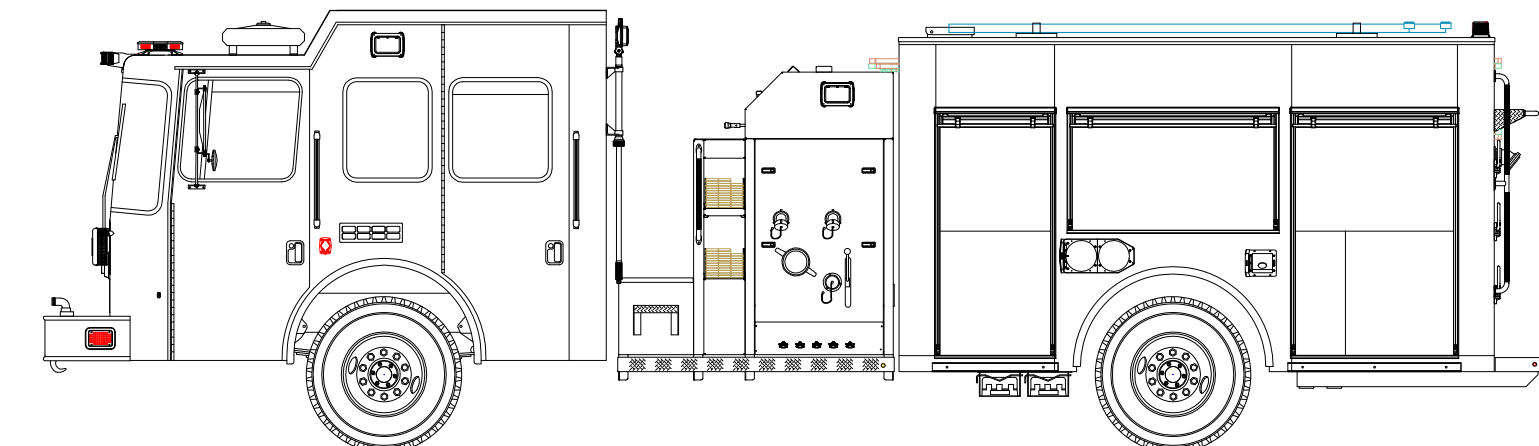
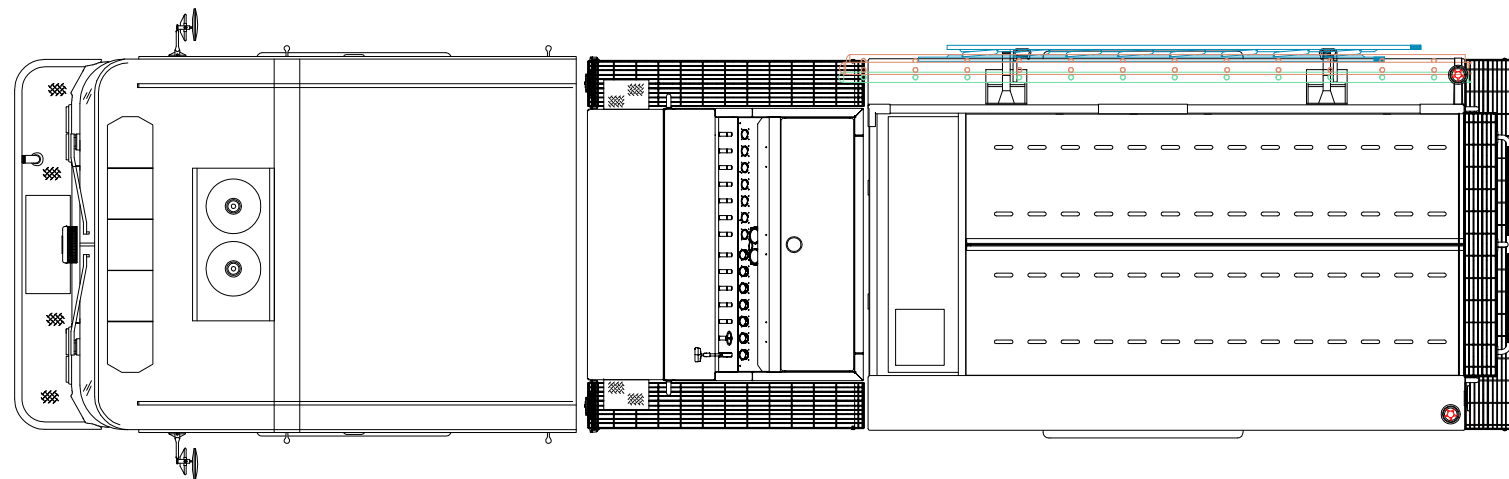
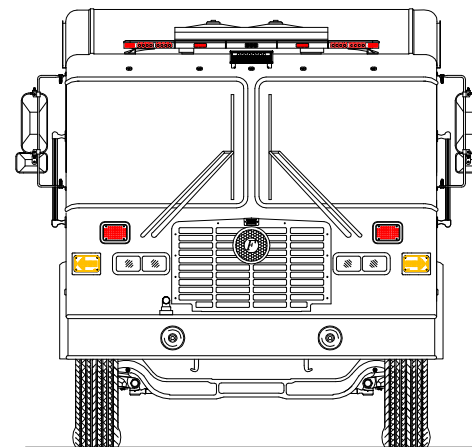
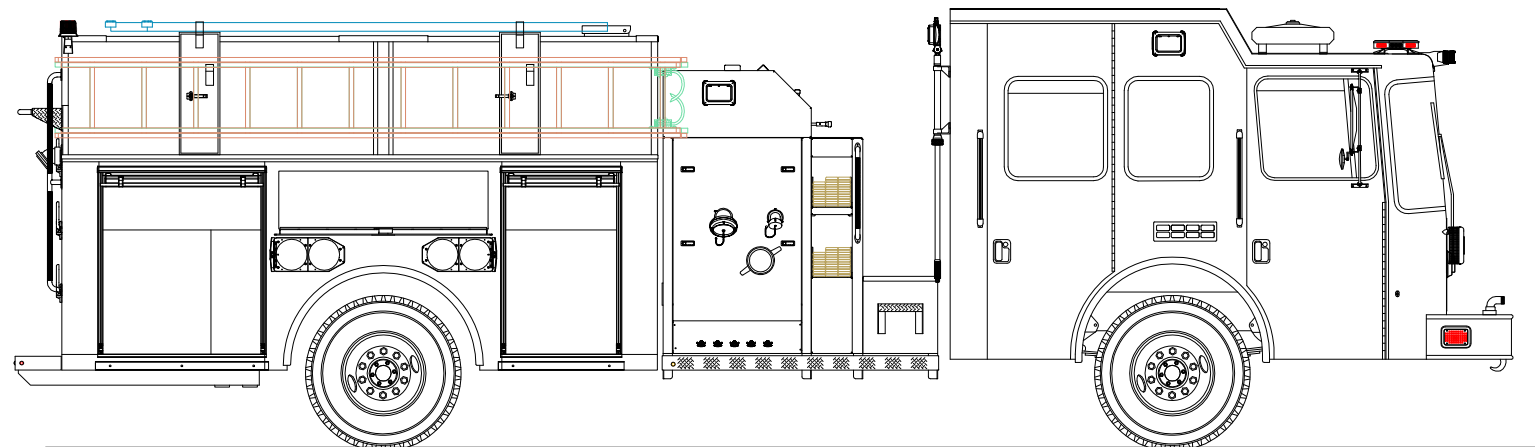

Pump Info:

| | |
|--------------------------------|----------------------------------|
| Control Location: Top | Apparatus Type: Pumper |
| Pump Drive: Split Shaft | Chassis: HME 60 - BOC |
| Pump Make: Darley | Tank Capacity: 1000 |
| Pump Model: PSM | |
| Pump GPM: 1500 | Material: Stainless Steel |

| REVISION HISTORY | | | |
|------------------|-------------|------|-----|
| REV | DESCRIPTION | DATE | DWN |
| | | | |

COMPARTMENT DIMENSIONS

| COMP # | DOOR OPENING SIZES |
|--------|------------------------------------|
| L1 | 30" WIDE X 61" HIGH X 12"/26" DEEP |
| L2 | 54" WIDE X 27" HIGH X 12" DEEP |
| L3 | 42" WIDE X 61" HIGH X 12"/26" DEEP |
| R1 | 30" WIDE X 45" HIGH X 12"/26" DEEP |
| R2 | 56" WIDE X 15" HIGH X 12" DEEP |
| R3 | 42" WIDE X 45" HIGH X 12"/26" DEEP |
| REAR | 36" WIDE X 44" HIGH X 37" DEEP |

UNLESS OTHERWISE SPECIFIED DIMENSIONS ARE IN INCHES TOLERANCES ARE NOT CUMULATIVE

DECIMAL ± 0.062 ANGULAR ± 0.5° FRACTIONAL ± 1/16 METRIC ± 1.6 mm

The copyright of this drawing and design and the right of reproduction there is vested in and belongs to Alexis Fire Equipment Co.

DRAWN M.TINKHAM 3/12/15

MATERIAL

Alexis FIRE EQUIPMENT CO.
P.O. BOX 549, ALEXIS, ILLINOIS 61412

PUMPER
ALEXIS FIRE EQUIPMENT COMPANY
ALEXIS, ILLINOIS

SIZE SCALE DWG NO
D 1/2"=1' P-V51

CONTRACT # 2315 SHEET 2 OF 2



Alexis Fire Equipment
Alexis, IL

Gentlemen:

We hereby propose to furnish, after your acceptance, approval, and proper execution of the accompanying contract, the fire apparatus as follows:

One (1) Alexis Custom Top Mount Pumper

As per specifications attached herewith.

TOTAL APPARATUS.....\$ *

* Does not include any applicable taxes. Any local or state tax, if applicable, must be added to the above price.

Shipment of completed apparatus shall be made within 330 calendar days after our approval of properly signed contract, subject to causes beyond our control. This proposal is made subject to your acceptance within thirty (30) days from date of same. If acceptance is delayed beyond that period, we will, upon request, advise you of any increase in said amount which may be occasioned by causes beyond our control.

Respectfully submitted,
ALEXIS FIRE EQUIPMENT COMPANY

By: _____

"QUALITY HAS NO SUBSTITUTE"

PAYMENT TERMS

OPTION 1

The chassis payment shall be made within ten (10) days of invoicing.

The balance of the contract plus any contract alterations shall be payable upon the delivery of the finished unit.

Upon payment, the Alexis Fire Equipment Company shall furnish the purchaser a "Statement of Origin" or the necessary validated documents required for title application.

OPTION 2

The chassis payment shall be made within ten (10) days of invoicing.

A progress payment of \$ shall be made within ten (10) days of invoicing, upon the initial construction of the apparatus body. The ___ Fire Department may **DEDUCT** \$ from the front page price for this payment.

The balance of the contract plus any contract alterations shall be payable upon the delivery of the finished unit.

Upon payment, the Alexis Fire Equipment Company shall furnish the purchaser a "Statement of Origin" or the necessary validated documents required for title application.

Additional payment terms available upon request.

ISO 9001:

Alexis Fire Equipment Company operates a Quality Management System under the requirements of ISO 9001. These standards, sponsored by the "International Organization for Standardization (ISO)," specify the quality systems that shall be established by the manufacturer for design, manufacture, installation and service.

DIGITAL PHOTOGRAPHS:

Digital photographs of apparatus under construction are taken on a weekly basis and emailed to a department supplied email address. Additionally, these photos are uploaded to our website at www.alexisfire.com allowing those department members who may not have access to the emailed photos to track the progress of the unit.



109 EAST BROADWAY • ALEXIS, ILLINOIS 61412 • P 800.322.2284 • F 309.482.6127 • SALES@ALEXISFIRE.COM

SERVICE CENTER:

The Alexis Priority-One service team is staffed with factory trained mechanics ready to meet your service requirements. Our staff is continually working on maintaining updated EVT and ASE certification.

The Alexis Service Team is available 24 hours a day, 7 days a week for your service emergencies. We use the latest paging system for fast, efficient and reliable service.

Our service facility covers an area of approximately 14,000 square feet.

The Alexis Service Team can assist you in fire apparatus service, ambulance service, aerial device maintenance, generator and rescue tool maintenance and service, and air pack inspections. Our staff can provide our customers with a complete apparatus training program, meeting the latest training requirements.

Alexis is a single source warranty center for the following manufacturers: HME, Spartan Motors, RK Aerials, Darley, Hale, and Waterous.

Our service team has over 50 years of cumulative experience in the fire service industry. In addition, they are backed by our fabrication, electrical, and paint and finish departments. This combination of training and hands-on experience offers true reliability and dependability.

Alexis keeps detailed documentation of all repair, maintenance, and inspection performed by our personnel. With time and manpower at such a premium among many fire departments, why not allow the Alexis Service Team to set up and maintain records for your fleet?

The Alexis Service Team is committed to providing prompt and courteous service, quality products and fair pricing.

Business: Alexis Fire Equipment Company

Contact Person: Barb Lafferty

Location: 109 East Broadway Alexis, IL 61412

Phone: 800-322-2284

DELIVERY:

To insure proper break-in of all drive train components while under warranty, the finished apparatus shall be delivered to the purchaser under its own power.

The apparatus shall be covered by comprehensive and liability insurance during the delivery period. The purchaser shall assume the insurance obligation on acceptance. At that time, the purchaser shall present to the manufacturer's agent a certificate of verification, showing liability, comprehensive, and collision insurance coverage.

A qualified representative shall remain in the department a sufficient length of time to demonstrate the operation, care and maintenance of the equipment to one (1) shift of personnel.



GENERAL INFORMATION:

LOCATION

The Alexis Fire Equipment facilities are located at 109 East Broadway, Alexis, Illinois 61412. We maintain a complete stock of parts and services available around-the-clock. We also propose to maintain parts and service for a minimum period of twenty (20) years on all apparatus which is manufactured.

NOTATION

To further assure the customer of our ability to manufacture quality fire apparatus, we are proud of the fact that Alexis Fire Equipment Company is family-owned and has been in the fire apparatus business since 1947.

PERSONNEL CAPACITIES

To meet the spirit of N.F.P.A. 1500 paragraph 6.3.1, this apparatus has been designed to transport not more than six (6) people.

6.3 Riding in Fire Apparatus

6.3.1 All persons riding in fire apparatus shall be seated and belted securely to the vehicle by seat belts in approved riding positions and at any time the vehicle is in motion. Standing or riding on tailsteps, sidesteps, running boards or in any other exposed position shall be specifically prohibited.

MAXIMUM TOP SPEED:

To meet the intent of NFPA 1901 4.15.2, the top speed of the vehicle shall not exceed 68 MPH or the manufacturer's maximum fire service speed rating for the tires installed on the apparatus, whichever is lower.

INFORMATION TO BE PROVIDED:

Alexis Fire Equipment Company shall supply, at the time of delivery, the following documents:

- A) The manufacturer's record of apparatus construction details, including the following information:
1. Owner's name and address

2. Apparatus manufacturer, model, and serial number.
 3. Chassis make, model, and serial number.
 4. GAWR of front and rear axles.
 5. Front tire size and total rated capacity in pounds.
 6. Rear tire size and total rated capacity in pounds.
 7. Chassis weight distribution in pounds with water and manufacturer mounted equipment.
 8. Engine make, model, serial number, number of cylinders, bore, stroke, displacement and compression ratio, rated horsepower and related speed, and no-load governed speed.
 9. Type of fuel and fuel tank capacity.
 10. Electrical system voltage and alternator output in amps.
 11. Battery make and model, capacity in CCA.
 12. Transmission make, model, and type.
 13. Pump to drive through the transmission (yes or no)
 14. Engine to pump gear ratio used
 15. Pump make, model, rated capacity in g.p.m., serial number, number of stages, and impeller diameter in inches.
 16. Pump transmission make, model, and serial number.
 17. Priming device type.
 18. Type of pump pressure control system.
 19. Auxiliary pump make, model, rated capacity in g.p.m., serial number, number of stages, and impeller diameter in inches.
 20. Water tank certified capacity in gallons.
 21. Aerial device type, rated vertical height in feet, rated horizontal reach in feet, and rated capacity in pounds.
 22. Paint numbers
 23. Company name and signature of responsible company executive.
- B) If the apparatus has a fire pump, the pump manufacturer's certification of suction capability.
- C) If the apparatus has a fire pump, a copy of the apparatus manufacturer's approval for stationary pumping applications.
- D) If the apparatus has a fire pump, the engine manufacturer's certified brake horsepower curve for the engine furnished, showing the maximum no-load governed speed.
- E) If the apparatus has a fire pump, the pump manufacturer's certification of hydrostatic test.
- F) If the apparatus has a fire pump, the certification of inspection and test for the fire pump.
- G) If the apparatus has an aerial device, the certification of inspection and test for the aerial device.
- H) If the apparatus has an aerial device, all the technical information required for inspections to comply with NFPA.
- I) Weight documents from a certified scale - showing actual loading on the front axle, rear axle(s), and overall vehicle (with the water tank full but without personnel, equipment, and hose) - shall be supplied with the completed vehicle.

- J) Written load analysis and results of the electrical system performance tests.
- K) If the apparatus is equipped with a water tank, the certification of water tank capacity.
- L) If the apparatus has a fire pump, two (2) copies of the pump operation and maintenance manual.
- M) Two (2) destination effective wiring diagrams.
- N) Copies of electrical and mechanical component manuals for equipment purchased on or with the apparatus.
- O) A sketch of the booster tank indicating all dimensions and baffle locations.
- P) If the apparatus has a pump, one (1) certification of third party test

WARRANTY:

Alexis Fire Equipment Co., Inc. warrants each new piece of fire and rescue apparatus manufactured by Alexis to be free from defects in material and workmanship under normal use and service for a period of one year from the date of delivery. Our obligation under this warranty is limited to furnish any parts to replace those that have failed due to defective material or workmanship, as the company may elect, provided that such part, or parts shall be returned to us not later than one year after delivery of such vehicle. All water tanks will be warranted as stated herein and may have extended warranty as explained elsewhere in the Alexis Fire Equipment Co. Proposal.

This warranty will not apply:

- 24. To normal maintenance services including, but not limited to, electrical lamps, valve seals, normal lubrication and/or proper adjustment of minor items.
- 25. To any vehicle which shall have been repaired or altered outside of our factory, in any way so as, in our judgment, to affect its stability, nor which has been subject to misuse, negligence, or accident, nor to any vehicle made by us which shall have been operated at a speed exceeding the factory rated speed, or loaded beyond the factory rated load capacity.
- 26. To the chassis and associated equipment furnished with chassis, signaling device, generators, batteries or other trade accessories. These are warranted separately by their respective manufacturers.
- 27. To work performed by an outside service without prior authorization obtained from Alexis Fire Equipment.
- 28. To costs incurred from an outside service for non-warranty related items.

This warranty is in lieu of all other warranties, expressed or implied, and all other representations to the original purchaser and all other obligations or liabilities, including liability for incidental or

consequential damages on the part of the company. We neither assume nor authorize any person to give or assume any other warranty or liability on the company's behalf unless made or assumed in writing by the company.

LENGTH AND/OR HEIGHT LIMITATIONS:

OVERALL HEIGHT:

The OAH of the unit shall not exceed 10'.

OVERALL LENGTH:

The OAL of the unit shall not exceed 34'

CHASSIS MODIFICATIONS:

MUD FLAPS:

Each rear fender shall be extended with a black rubber mud flap, thus preventing splash and road debris from damaging the apparatus body.

WHEEL DRESS HUB AND NUT COVERS:

The front and rear wheels shall be dressed with polished hub covers and lug nut covers.

LABELS:

A permanent plate in the driving compartment shall specify the quantity and type of the following fluids used in the vehicle:

- Engine Oil
- Engine Coolant
- Chassis Transmission Fluid
- Pump Transmission Lubrication Fluid
- Pump Primer Fluid (if applicable)
- Drive Axle(s) Lubrication Fluid
- Air-Conditioning Refrigerant
- Air-Conditioning Lubrication Oil
- Power Steering Fluid
- Cab Tilt Mechanism Fluid

- Transfer Case Fluid
- Equipment Rack Fluid
- CAFS Air Compressor System Lubricant
- Generator System Lubricant
- Front Tire Cold Pressure
- Rear Tire Cold Pressure
- Maximum Tire Speed Ratings

A final manufacturer's certification of the GVWR or GCWR along with a certification of each GAWR, shall be supplied on a label affixed to the vehicle.

A sign that reads "Occupants Must Be Seated and Belted When Apparatus Is in Motion" shall be provided. The sign shall be visible from each seated position.

A label that states the number of personnel the vehicle is designed to carry shall be located in an area visible to the driver.

A sign stating the overall height of the vehicle in feet and inches, the overall length of the vehicle in feet and inches, and the GVWR in tons shall be provided and mounted. The sign shall be visible to the driver of the vehicle while seated.

A label stating "Do Not Wear Helmet While Seated" shall be visible from each seating position.

FUEL TANK:

The chassis shall incorporate a rear fuel tank installed by the chassis manufacturer. The fill and vent shall be installed behind the left rear wheel in a recessed housing with a hinged stainless steel door, Model 101426. The fill shall be labeled with the type of fuel intended.

CAB TILT PENDANT CONNECTION:

The chassis supplied cab tilt connection shall be mounted on the right side of the apparatus. For a pumper, the receptacle shall be located on the discharge panel. For a rescue, the receptacle shall be located in the R1 compartment.

BUMPER EXTENSION HOSE TRAY - FULL WIDTH:

One (1) full width hose tray shall be provided on the front bumper. The tray shall be manufactured of aluminum treadplate material and shall be mounted on top of the chassis supplied gravel shield.

The hose tray shall incorporate one (1) nylon buckle assembly in the center to retain the hose within the tray during travel.

The hosewell shall have the capacity to contain 150' of 1 $\frac{3}{4}$ " hose.

AIR LIMITER:

A limiter valve shall be installed on the chassis air reserve tank, eliminating the use of all air accessories when the chassis air pressure is under 100 psi, thus reserving all available air for braking effort.

HELMET STORAGE:

To meet the intent of NFPA 14.1.8.4.1, the helmet for each occupant shall be stored in an exterior compartment.

PUMP AND PIPING:

DARLEY PSM 1500 SPLIT SHAFT PUMPING SYSTEM:

MANUFACTURER: DARLEY
MODEL: PSM 1500
CAPACITY:1500 gpm at 150 psi

A Darley model PSM 1500 GPM single stage split-drive shaft driven fire pump shall be provided and installed.

The pump shall be midship mounted and designed to operate through an integral transmission, including a means for power selectivity to the driving axle or to the pump. The pump shall be driven by a driveline from the chassis transmission. The engine, transmission and driveline components shall provide sufficient horsepower and RPM to enable the pump to meet and exceed its rated performance.

The pump shall contain a cored heating jacket feature that, if selected, can be connected into the vehicle antifreeze system to protect the pump from freezing in cold climates, and to help reject engine heat from engine coolant, providing longer life for the engine.

Pump Shaft

The pump shaft shall be precision ground stainless steel with long wearing Chromium Oxide hard coating under the packing glands with a hardness level of #RC72. The shaft shall be splined to receive

broached impeller hubs, for greater resistance to wear, torsional vibration, and torque imposed by engine, as well as ease of maintenance and repair.

The bearings provided shall be heavy duty, deep groove, radial type ball bearings. Sleeve bearings on any portion of the pump or transmission shall be prohibited due to wear, deflection, and alignment concerns. The bearings shall be protected at all openings from road dirt and water splash with oil seals and water slingers.

Impeller

The impeller shall be a high strength bronze alloy of mixed flow design, splined to the pump shaft for precision fit, durability, and ease of maintenance. Impeller shall be vacuum cast designed for maximum lift and highest capacity. The seal rings shall be renewable, double labyrinth, wrap around bronze type.

Impeller shaft oil seals shall be constructed to be free from steel components except for the internal lip spring. The impeller shaft oil seals shall carry a lifetime warranty against damage from corrosion from water and other fire-fighting fluids.

Pump Transmission

The transmission case shall be heavy duty cast iron. A magnetic drain plug shall be provided. Transmission case shall include a dip stick for checking oil level. Transmission case interior shall be powder coated to reduce oil contamination. Transmission case shall be equipped with a removable plate for quick inspection of gears, shafts, and bearings inside the transmission.

The pump drive shaft shall be precision ground, heat treated alloy steel, with a minimum 2-1/2" x 10" spline. The net through-torque rating of the gearbox shall exceed 19,000 foot pounds. Gears shall be helical design, and shall be precision ground for quiet operation and extended life. The gears shall be manufactured from alloy steel and carburized for surface hardness and strength.

The pump clutch gear shall be a heat treated alloy-steel splined spur gear to engage either the pump drive gear or the truck drive shaft gear, and shall have bullet-nosed teeth to reduce the possibility of a butt-tooth condition. The pump clutch gear shall be separate from the main drive gear in order to maintain the greatest precision for driving the pump gear train. The pump transmission shall require no further lubrication beyond that provided by the intrinsic action of the gears, to reduce the likelihood of failure due to loss of auxiliary lubrication.

Driveline Installation

The chassis drivelines shall be sized for intended application and torque requirements. The installation shall comply with driveline manufacturer's guidelines.

Manuals

Two (2) manuals covering the fire pump transmission and selected options of the fire pump shall be provided with the apparatus.

PRIMING PUMP:

The priming pump shall be a Trident Emergency Products compressed air-powered, high efficiency, multi-stage, venturi based AirPrime™ System. All wetted metallic parts of the priming system are to be of brass and stainless steel construction. A single panel mounted control will activate the priming pump and open the priming valve to the pump. The priming system shall have a five year warranty.

The priming pump shall be controlled from the pump operator's panel.

DRIVELINES:

The chassis drivelines shall be modified to accept the pump drivelines. The pumping system drivelines shall be manufactured by the apparatus manufacturer. The drivelines shall be professionally balanced by the apparatus manufacturer to ensure complete system balance.

6" SUCTION:

One (1) 6" NST suction shall be located on each side of the apparatus body. The suctions shall be open and not gated. An inlet screen and a 6" handle cap shall be included.

PIPING:

The piping will be stainless steel material throughout the waterway system. The suction waterway shall be 6" 304 stainless steel material. The suction waterways shall be designed to flow a minimum of 17% in excess of the rated capacity from draft. The suction piping shall incorporate a 4" suction inlet to allow for full flow from the tank valve assembly. The suction piping shall be adapted from 6" TIPT to NST with a chrome adapter. The suction system shall be designed with 6" victaulic couplings to allow ease of access for maintenance or removal of the pumping system.

The discharge system shall incorporate a 4" x 6" stainless steel distribution system. The manifold shall be fed from the 4" piping system. The discharge system shall incorporate a 4" victaulic system to allow ease of access for maintenance or removal of the pumping system. Each discharge shall be fed from

above the manifold system.

PUMP DRAINS:

The entire pump and its controls shall be drainable with a master drain piped to the lowest points of the pump and its control piping. The master drain shall be of a threaded design that will seal all drain points without allowing recycle.

MECHANICAL SEAL:

The pump shall be furnished with a Darley maintenance free mechanical seal. The mechanical seal shall be a non-contacting, non-wearing dual seal design. Seal shall be a Silicon Carbide Mechanical seals with welded springs. The stationary face of mechanical seals shall be made from Silicon Carbide, and be extremely hard and of a heat dissipative material, which resists wear and dry running damage much better than conventional Ni-resist and Tungsten Carbide materials

AIR PUMP SHIFT:

The shifting mechanism shall be a heat-treated, hard anodized aluminum power cylinder, with stainless steel shaft. The assembly shall be plumbed utilizing a 3/8" air line for maximum performance. An in-cab control for rapid shift shall be provided that locks in road or pump.

For automatic transmissions, three green warning lights shall be provided to indicate to the operator(s) when the pump has completed the shift from Road to Pump position. Two green lights to be located in the truck driving compartment and one green light on pump operators panel adjacent to the throttle control. For manual transmissions, one green warning light will be provided for the driving compartment. All lights shall have appropriate identification/instruction plates.

INTAKE PRESSURE RELIEF VALVE

One (1) Task Force Tips model #A1860 pressure relief valve shall be provided. The valve shall have an easy to read adjustment range from 90 to 300 PSI with easy to read 90, 125, 150, 200, 250, 300 psi settings and an "OFF" position. Pressure adjustment can be made utilizing a 1/4" hex key, 9/16" socket or 14mm socket. For corrosion resistance the cast aluminum valve shall be hardcoat anodized with a powder coat interior and exterior finish. The valve shall be configured for either a Waterous or Hale pump, and have a 2-1/2" male NH threaded discharge outlet and a "DO NOT CAP" label near discharge outlet. The valve shall meet NFPA 1901 requirements for pump inlet relief valve. The unit shall be covered by a five-year warranty.

REQUIRED PUMP TESTING:

If the fire pump has a rated capacity of 750 gpm or greater capacity, the pump shall be tested after the pump and all its associated piping and equipment have been installed on the apparatus. The tests shall be conducted at the Alexis facility and certified by an EVT Certified pump operator. The certification shall include (at least) the following tests: the pumping test, the pumping engine overload test, the pressure control system test, the priming device tests, and the vacuum test. If the apparatus is equipped with a water tank, the water tank to pump flow test shall be included.

A test plate shall be provided at the pump operator's position that gives the following information: the rated discharges and pressures, the speed of the engine determined by the certification test for each unit, the position of the parallel/series pump as used, and the no-load governed speed of the engine stated by the engine manufacturer on a certified brake horsepower curve. The plate shall be completely stamped with all information at the factory and attached to the vehicle prior to shipping.

PUMP CERTIFICATION:

Upon final apparatus delivery, the original copy of the certificate of inspection by an independent third party shall be furnished.

The pumping system shall be capable of delivering:

- 100 % of rated capacity at 150 psi. net pump pressure
- 70 % of rated capacity at 200 psi. net pump pressure
- 50 % of rated capacity at 250 psi. net pump pressure

PUMP MODULE - TOP MOUNT:

A free standing pump module shall be located between the chassis cab and the body.

The pump module shall be a self-supported structure mounted to the frame separate from the cab and body. Pump module design beginning with a formed framework assemblies that are precision manufactured from corrosion free heavy 7 gauge stainless steel forms. This framework mounts to the truck frame through a mounting design complimented with four (4) VIBRA mount elastomer cushions. The result shall be a mounting system that allows for the twisting movement of the truck frame without undue stress loading of the pump module.

The pump operator's panel shall be located across the top of the apparatus, and the suction/discharge panels shall be located on the left and right sides of the apparatus.

An automotive rubber seal shall be adhered to the pump panel to reduce vibration that may occur during pump operation or road application. The panel shall be attached to the framing with 3/16" pin, 1"

knuckle, continuous stainless steel hinges. The hinges shall be attached with stainless steel fasteners.

Each panel shall be secured with latches at the top and bottom of the door opening.

The top mount operator's panel shall be hinged for access to the individual gauges and the electrical components. No exceptions.

Once the module is designed, the valve control placements on a control module shall result in a neat and orderly layout. Open the access door on a side control module and peer inside. The horizontal control rods appear neat and orderly.

PUMP OPERATOR'S PANEL:

The pump operator's panel shall include the following:

PRESSURE GOVERNOR and MONITORING DISPLAY

One (1) Fire Research PumpBoss series PBA400-A00 pressure governor and monitoring display kit shall be installed. The kit shall include a control module, intake pressure sensor, discharge pressure sensor, and cables. The control module case shall be waterproof and have dimensions not to exceed 6 3/4" high by 4 5/8". The control knob shall be 2" in diameter with no mechanical stops, have a serrated grip, and a red idle push button in the center. It shall not extend more than 1 3/4" from the front of the control module. Inputs for monitored information shall be from a J1939 databus or independent sensors. Outputs for engine control shall be on the J1939 databus or engine specific wiring.

The following continuous displays shall be provided:

- Engine RPM; shown with four daylight bright LED digits more than 1/2" high
- Check engine and stop engine warning LEDs
- Engine oil pressure; shown on a dual color (green/red) LED bar graph display
- Engine coolant temperature; shown on a dual color (green/red) LED bar graph display
- Transmission Temperature: shown on a dual color (green/red) LED bar graph display
- Battery voltage; shown on a dual color (green/red) LED bar graph display
- Pressure and RPM operating mode LEDs
- Pressure / RPM setting; shown on a dot matrix message display
- Throttle ready LED.

A dot-matrix message display shall show diagnostic and warning messages as they occur. It shall show monitored apparatus information, stored data, and program options when selected by the operator. All LED intensity shall be automatically adjusted for day and night time operation.

The program shall store the accumulated operating hours for the pump and engine to be displayed with the push of a button. It shall monitor inputs and support audible and visual warning alarms for the following conditions:

- High Battery Voltage
- Low Battery Voltage (Engine Off)
- Low Battery Voltage (Engine Running)
- High Transmission Temperature
- Low Engine Oil Pressure
- High Engine Coolant Temperature
- Out of Water (visual alarm only)
- No Engine Response (visual alarm only).

The program features shall be accessed via push buttons located on the front of the control module. There shall be a USB port located at the rear of the control module to upload future firmware enhancements.

The governor shall operate in two control modes, pressure and RPM. No discharge pressure or engine RPM variation shall occur when switching between modes. A throttle ready LED shall light when the interlock signal is recognized. The governor shall start in pressure mode and set the engine RPM to idle. In pressure mode the governor shall automatically regulate the discharge pressure at the level set by the operator. In RPM mode the governor shall maintain the engine RPM at the level set by the operator except in the event of a discharge pressure increase. The governor shall limit a discharge pressure increase in RPM mode to a maximum of 30 psi. Other safety features shall include recognition of no water conditions with an automatic programmed response and a push button to return the engine to idle.

The pressure governor and monitoring pressure display shall be programmed at installation for a specific engine.

MASTER GAUGES:

One (1) 4½" compound gauge with a range of 30-0-600 PSI.

One (1) 4½" pressure gauge with a range of 0-600 PSI

WATER TANK INDICATOR

One (1) Fire Research TankVision model WLA200-A00 tank indicator kit shall be installed. The kit shall include an electronic indicator module, a pressure sensor, and a 10' sensor cable. The indicator shall show the volume of water in the tank on nine (9) easy to see super bright LEDs. A wide view lens over the LEDs shall provide for a viewing angle of 180 degrees. The indicator case shall be waterproof, manufactured of aluminum, and have a distinctive blue label.

The program features shall be accessed from the front of the indicator module. The program shall support self-diagnostics capabilities, self-calibration, and a datalink to connect remote indicators. Low water warnings shall include flashing LEDs at 1/4 tank, down chasing LEDs when the tank is almost empty, and an output for an audio alarm.

The indicator shall receive an input signal from an electronic pressure sensor. The sensor shall be mounted from the outside of the water tank near the bottom. No probe shall place on the interior of the tank. Wiring shall be weather resistant and have automotive type plug-in connectors.

The gauge shall be located at the pump operator's panel.

LINE READING GAUGES:

One (1) line reading gauge supplied for each discharge. The gauge shall have a 2½ diameter face with a graduated output scale of 0-400 PSI with black print on a bright white background. The gauge shall be constructed with a Zytel housing, acrylic lens and polished stainless steel bezel. The Zytel nylon case shall be temperature compensated with an internal breathing diaphragm to permit a fully filled case and to allow for a rigid lens with a distortion free viewing area.

A 1/4" brass male NPT fitting shall be centrally located on the rear of the housing and feature the Kem-X socket and freeze protection system that isolates the gauge from contaminants. The gauge utilizes a phosphor bronze Bourdon tube filled with a freeze proof liquid isolated by a diaphragm. The gauge shall be filled with low temperature glycerin for an operating range of -40 to +150 degrees Fahrenheit, which prevents bouncing of the readout needle and provides for an accuracy rating of plus or minus 1% across the entire scale of the gauge.

COLOR CODED TAGS:

Color coded tags with chrome plated bezels shall be provided. Unless otherwise specified all tags shall be color coded to NFPA recommendations and shall be located at the control location, intake/discharge location, and at the drain port location.

TEST PORTS:

Vacuum and pressure test ports shall be provided on the pump operator's panel for connection of the pump test gauges.

PUSH BUTTON ON PUMP PANEL FOR AIR HORNS:

There shall be a push button provided on the pump panel to activate the air horns.

MIDSHIP WALKWAY

A 22" wide walkway shall be incorporated behind the cab and ahead of the body. The walkway shall be framed and supported with an extruded aluminum frame work. The walkway shall be constructed of 3/16" thick 3003-H12 polished aluminum treadplate and attached to the substructure with stainless steel threaded fasteners.

LED WALKWAY COURTESY LIGHTS:

Two (2) Eon E03 Series LED courtesy lights shall illuminate the pump operator's walk way. They shall be switched with the parking brake.

GRAB HANDLES:

Two (2) 24" knurled bright stainless steel 1¼" o.d. grab rails shall be installed, one (1) on each side of the body at the walkway area.

RUNNING BOARDS

The running boards shall be constructed of open serrated grating material and shall be attached to the outriggers on the pump module. The open design prevents accumulation of moisture and debris. The front and side faces of each running board covered with polished aluminum treadplate. The serrated grating material meets NFPA standard 13-7.3: all exterior surfaces have a minimum slip resistance of .68.

STAINLESS STEEL PUMP MODULE:

The area above the side discharge panels on each side shall be manufactured of 14 gauge brushed stainless steel material.

PUMP PANELS:

The top mount pump operator's panel shall be manufactured of 12 gauge stainless steel material and shall include a full width light hood. The operator's panel shall have three (3) E10 Series LED lights

The side discharge panels on the left and right sides of the apparatus shall be manufactured of .190 smooth aluminum and shall include two (2) Eon E03 Series LED lights above the discharge panel. The

panels shall be coated with a flexible black polyurethane material. The material gives the panels a glare resistant and chemically resistant finish that is designed for the fire industry.

The lights activated by the pump panel light switch.

2 ½" DISCHARGE PIPING:

Two (2) 2 ½" discharge(s) shall be located on the left side of the apparatus. Each discharge valve shall be located behind the body panel and controlled from the top mount pump operator's panel. Each discharge shall include a self-locking 2½" quarter-turn ball valve, a 2½" chrome cap with chain, and a sweep elbow of at least 30 degrees downward.

Each above valve shall be manually controlled.

2 ½" DISCHARGE PIPING:

One (1) 2 ½" discharge(s) shall be located on the right side of the apparatus. Each discharge valve shall be located behind the body panel and controlled from the top mount pump operator's panel. Each discharge shall include a self-locking 2½" quarter-turn ball valve, a 2½" chrome cap with chain, and a sweep elbow of at least 30 degrees downward.

Each above valve shall be manually controlled.

2 ½" DISCHARGE, APPARATUS REAR:

One (1) 2½" discharge shall be located on the rear of the apparatus. Each discharge shall be controlled from the top mount pump operator's panel. Each shall include a self-locking 2½" quarter-turn ball valve, a 2½" chrome cap with chain, and a sweep elbow of at least 30 degrees downward.

Each above valve shall be manually controlled.

LOCATION: _____

3" DISCHARGE, APPARATUS RIGHT SIDE:

One (1) 3" discharge shall be located on the right side of the apparatus with the valve behind the body panel. The discharge shall be controlled from the top mount pump operator's panel. A 2½" gauge shall be adjacent to the control. Each 3" and larger discharge shall include an Akron Slo-Cloz adapter.

DISCHARGE ADAPTER:

The 3" discharge shall incorporate one (1) 3" NST LHF x 5" Storz 30 degree elbow with blind cap.

Each above valve shall be manually controlled.

TANK TO PUMP LINE:

One (1) 3" tank to pump line shall be installed into the tank to the suction side of the pump. It shall have 4" piping and valved with a 3" full flow valve. The valve shall be controlled from the pump operator's panel. The tank line shall incorporate a check valve in the line to meet NFPA 1901.

LINE DRAINS FOR DISCHARGES:

The drain valves shall be Innovative Controls ¾" ball brass drain valves with chrome-plated lift lever handles and ergonomic grips. Each lift handle grip shall feature built-in color-coding labels and a verbiage tag identifying each valve, also supplied by Innovative Controls. The color labels shall also include valve open and close verbiage.

VENTED DISCHARGE CAPS:

Each discharge shall incorporate a vented cap designed to relieve stored pressure in the line when disconnected.

GATED SUCTION, LEFT SIDE:

One (1) 2½" gated suction shall be located on the left side of the apparatus. It shall be piped 2½" i.d. including a 2½" Akron full flow quarter turn valve and a 2½" NST female swivel with plug and chain. It shall be remote controlled from the suction location.

Each above valve shall be manually controlled.

REAR SUCTION PROVISION:

The suction manifold, pump panel, and body shall include provisions for a 5" rear suction.

SUCTION LINE DRAINS:

Each 2½" gated suction and those of larger sizes shall incorporate a ¾" quarter turn drain hoses to ground. The drain shall be located behind the body panel, remote controlled from the suction location.

FOAM PROPORTIONER PROVISIONS:

The pump plumbing system shall include provisions for a potential single tank foam proportioning system.

FIXED MONITOR PIPING:

One (1) 3" discharge shall be located on the deck over the pump compartment. The discharge shall be flanged to adapt to a permanent mounted deck pipe. The piping shall be reinforced to allow rated deck pipe flow without piping distortion. The discharge valve shall be a quarter turn 3" full flow valve located in the pump compartment. It shall be controlled from the pump panel. The deluge and its control shall be positioned so the pump operator shall have complete control. The valve shall be a slow close valve per NFPA requirements.

Each above valve shall be manually controlled.

CARTRIDGE LAY PRECONNECT MODULE - (2) 1½":

One (1) independent preconnect module shall be located ahead of the pump module, above the frame rails. The module shall be manufactured of stainless steel material, self supported, and shall incorporate two (2) preconnect hose beds.

Two (2) 1½" cartridge lay preconnects shall be located in the module. The preconnects shall incorporate a 1½", 180° Elkhart 348 swivel adapted to 1½" fire hose thread. The waterways shall be 2" i.d. and include a 2" full flow quarter turn ball valve that is controlled from the operator's panel (NFPA 4-7.2).

Each preconnect shall have the capacity to contain a minimum of 200 ft. of 1¾" hose with nozzle. The preconnects shall be designed as to allow the extension of hose to the left or right side of the apparatus body.

Each above valve shall be manually controlled.

Aluminum trays shall be incorporated with the system. Each tray shall be constructed of .1875" 5052 - aluminum sheet that is fabricated to accommodate the intended usage. Each cartridge shall be securely retained in the apparatus when in place. Aluminum abrasion plates shall be located on each side of the apparatus to protect body panels from the hose and its couplings during hose extension.

PRECONNECT COVER:

The preconnect area shall be covered with black die cut hypalon webbing. It is to be retained to the

apparatus with a screws across the bottom and two (2) nylon buckles at the top.

1½" PRECONNECT, BUMPER EXTENSION:

One (1) 1½" preconnect shall be incorporated within the bumper extension. The piping shall measure 2" i.d. and shall be valved with 2" full flow quarter turn ball valves that are controlled from the operator's panel. It shall include a bumper deck mounted 1½" swivel adapted to 1½" fire hose thread

Each above valve shall be manually controlled.

TANK FILL RECYCLE:

One (1) 2" waterway shall be incorporated from the pressure side of the pump to the tank. The line shall be controlled from the pump panel and valved with a 2" ball valve to allow a pump cooling recycle or tank fill when pumping from draft. When fully opened, it shall have the capacity to refill the tank at 750 gpm when pumping at 100 psi.

VALVING:

Each and every apparatus valve must be an Akron Stainless Steel Ball Valve, per the following specifications.

An Akron Brass Generation II Swing-Out™ Valve, shall be provided. The valve shall have an all brass body with flow optimizing stainless steel ball and dual polymer seats. The valve body shall be of universal design and accept multiple actuators. The valve shall be capable of dual directional flow while incorporating a self-locking ball feature using an automatic friction lock design and specially designed flow optimizing stainless steel ball. The stainless steel ball shall have HydroMax™ technology. All stainless steel parts must be 316 grade for increased resistance to corrosion. The valve shall not require lubrication of seats or any other internal waterway parts, and must be capable of swinging out of the waterway for maintenance by the removal of six bolts. The valve shall be compatible with a slow closing devise. This valve shall be actuated using a manual handle. The handle shall be quickly adjustable to one of eight handle positions and require only 90° travel. The valve shall be manufactured and assembled in the United States. Product must carry a 10 year manufacturer's warranty.

WARRANTY, AKRON BRASS BALL VALVE:

We warrant Akron Brass Swing-Out Valves for a period of ten (10) years after purchase against defects in material or workmanship. Akron Brass will repair or replace any Swing-Out Valve which fails to satisfy this warranty. Repair or replacement shall be at the discretion of Akron Brass. Electrical Components shall carry our standard five (5) year warranty. We will not be responsible for: Wear and

tear; and by improper installation use, maintenance; negligence of the owner or user; repair or modification after delivery; failure to follow our instructions or recommendations; or anything else beyond our control. WE MAKE NO WARRANTIES EXPRESS OR IMPLIED, OTHER THAN THOSE INCLUDED IN THIS WARRANTY STATEMENT, AND WE DISCLAIM ANY IMPLIED WARRANTY OF MERCHANTABILITY OR FITNESS FOR ANY PARTICULAR PURPOSE. Further we will not be responsible for any consequential, incidental, or indirect damages (including, but not limited to, any loss of profits) from any cause whatsoever. No person has authority to change this warranty.

PIPING:

All waterways described herein shall be of schedule 40 threaded stainless steel pipe, schedule 10 welded stainless steel, or "aeroquip" hose. Each shall be installed with the proper couplings to allow apparatus twisting, flexing, and complete removal for service or replacement.

PLUMBING WARRANTY:

The stainless steel plumbing components and ancillary brass fittings used in the construction of the water/foam plumbing system shall be warranted for a period of ten (10) years or 100,000 miles. This covers structural failures caused by defective design or workmanship, or perforation caused by corrosion, provided the apparatus is used in a normal and reasonable manner. This warranty is extended only to the original purchaser for a period of ten (10) years or 100,000 miles from the date of delivery.

PIPING CERTIFICATION:

Upon final apparatus delivery, a certification sheet shall accompany the unit stating that all piping and the pump have been hydrostatically tested to 250 psi.

BODY:

BODY WARRANTY:

Alexis Fire Equipment Company hereby extends its standard one-year fire and rescue apparatus warranty to include defects in materials and workmanship of the body as well as structural defects which, in the sole opinion of the company, substantially affect the total integrity of the body. This warranty is extended only to the original user-purchaser.

Alexis Fire Equipment warrants the 3/16" aluminum and 12 gauge stainless steel bodies, fabricated by Alexis Fire Equipment, under normal use and with reasonable maintenance, shall remain structurally sound for a period of 20 years or 100, 000 miles as long as the design of the apparatus complies with

Alexis engineering practices.

The Company reserves the right to require any such repairs to be made either at Alexis Fire Equipment Company, Inc. or another approved service facility, at the option of Alexis Fire Equipment. Transportation cost to and from the servicing location is the responsibility of the user-purchaser.

The warranty shall be null and void if, upon inspection by the Company, the alleged defect is determined to have been caused by abuse, modification, accident, neglect, or lack of proper maintenance.

This warranty does not apply to the following items that are covered by a separate warranty: paint finish, hardware, door assemblies, moldings, and other accessories attached to the body. In addition, this warranty does not apply to any part or accessory manufactured by others and attached to the body.

Alexis Fire Equipment will be given a reasonable opportunity to investigate all claims. The purchaser must commence any action arising out of, based upon or relating to agreement or the breach hereof, within twelve (12) months from the date the cause of the action occurred.

Alexis Fire Equipment makes no other warranty, expressed or implied, with respect to the apparatus body and all implied warranties of merchantability and fitness for a particular purpose are hereby disclaimed.

BODY SUB FRAME – GALVANIZED STEEL:

The body sub frame system shall be designed for the emergency service application. The sub frame shall be independent of the chassis frame and is to be constructed of heavy structural material to provide the maximum strength and body support necessary for units utilized in emergency service. The system not only is used for total support designed to carry the total load of the apparatus; the system also allows the unit to be a complete lift off transferable apparatus once completed.

The system is designed to carry the emergency apparatus on the chassis main frame in a European style method. This method allows the apparatus body to float independently from the chassis frame ahead of the rear wheels and shall be rigidly attached behind the rear axle area.

The sub frame system shall be isolated from the chassis frame with a custom full length rubber extrusion that totally locks onto each chassis frame rail. This system isolates the body from the frame while also acting as a cushion between the two units.

The sub frame system shall be a complete structural steel sub frame with downriggers and outriggers for maximum strength and proper flexibility of the frame. The steel sub frame shall incorporate 6 x 6 x .375 ASME angle which shall run full length of the chassis frame. The angle allows heavy duty stability to

each outrigger installed on the unit. This system will keep the outriggers from deflecting once the unit is loaded.

Each outrigger shall consist of 4" x 2" x .250 gauge steel rectangular tubing vertical downriggers to continue the total sub frame support. The horizontal under compartment outrigger shall be manufactured of a custom 7 gauge steel material which is formed in a channel design for maximum support. The horizontal outriggers shall include a minimum of two (2) custom designed **VibraCenters** installed on each outrigger to support the load of the body. This system also supports the compartment load and allows it to absorb the road energy and prevent premature wear of the customer's equipment which is loaded in the apparatus. Each **VibraCenter** is designed to carry the load of the apparatus per NFPA guidelines and to absorb shock loads in excess of 10 g's.

If the apparatus incorporates a rear drop sleeper design the sleeper system shall incorporate the 4 x 2 x .250 rectangular sleeper system for maximum body support.

The tank cradle shall be incorporated within the sub frame system to allow for a lower vertical center of gravity and to allow the water load weight to be supported by the sub frame system. The tank cradle shall incorporate the heavy sub frame and 3 inch steel channel placed in accordance with the poly tank manufacturer's recommendations. Each channel is covered with a custom extruded rubber channel to prevent the water tank from chaffing with the stainless steel sub frame.

All welds which are butt welded must and shall be furnished with a steel web plate for additional weld strength. It is important to note all welds on the sub frame system shall be welded in methods that are sanctioned by ASME and SAE standards as to allow complete structural integrity as stipulated and shall also follow the guidelines set forth by the Alexis Standards.

After the sub frame is totally manufactured the sub frame shall be galvanized in the following method with no exceptions.

- **Caustic Stage:** The steel is submersed in a hot caustic tank. This removes soil, oil, grease, and soluble plants
- **Acid Stage:** The steel is immersed in a hydrochloric acid tank to remove surface rust, mill scale, and similar deposits. The surface of the steel is pure metallic known ready to be fluxed
- **Pre-Flux Stage:** The steel is immersed in a hot pre-flux solution of zinc ammonium chloride. This prevents oxidation and keeps the surface reactive prior to dipping in molten zinc.

- Molten Zinc Stage: The steel is immersed in a molten zinc kettle, during this time the zinc metallurgically bonds to the iron and covers the steel with a zinc coating. All surfaces of the object are fully coated, including the inside of tubular structures and hard to reach areas.

It is important to note during that the manufacturing of the sub frame strategic notches and holes will be placed to allow the molten material to totally encapsulate the sub frame system.

APPARATUS FRONT PANEL:

The vertical surfaces between the body panels at the front of body shall be manufactured of 14 gauge 304 stainless steel material.

STAINLESS STEEL BODY PANELS:

The apparatus body panels shall be full height and independent of the tank's sides. The body panels shall be constructed of 14 gauge #4 304 stainless steel material.

APPARATUS REAR PANEL:

The vertical surfaces between the body rails at the rear, from the tailstep walkway to the hose bed, shall be manufactured of smooth stainless steel, in preparation for Chevron striping.

FLAT BACK TRUCK DESIGN:

The apparatus shall be of a flat back design so as to allow for ease of access to the hosebed.

WHEEL HOUSING, PAINTED SMOOTH STAINLESS STEEL:

The rear wheel housing shall be constructed of painted stainless steel and shall incorporate a polished stainless steel fenderette. The circular interliner shall be manufactured of 3/16" Tivar 1000 polymer material.

The polymer material is a chemical and corrosion resistant material, thereby preventing excess wear and corrosion from occurring due to wintertime road chemicals. The polymer material shall be held in place by the use of polymer retainers or bolts for ease of repair and access to the wheel well area.

HOSE MAT:

The hose mat shall be constructed of 5052 aluminum and shall be of a slatted design to provide proper drainage of hose bed.

TAILSTEP:

The tailstep shall be constructed of open serrated grating material, thereby preventing moisture and debris accumulation. The rear and side faces of the tail step shall be polished aluminum treadplate. The serrated grating material meets NFPA standard 13-7.3: all exterior surfaces have a minimum slip resistance of .68.

REAR TOW EYE:

One (1) drop forged steel drawbar tow eye with a 2½" I.D. eye and 1½" O.D. shank shall be mounted between the chassis frame rails. It shall be located behind a hinged treadplate access door in the rear compartment.

DUAL BOTTLE AIR BOTTLE COMPARTMENT(S):

Three (3) Model 101400-1X air bottle storage compartment(s) shall be located in the apparatus wheel well assemblies. For ease of access, each bottle shall be stored within an individual storage tube manufactured of poly material. The compartment shall incorporate a vertically hinged stainless steel door with a black push button latch. Each compartment shall have the capacity to carry two (2) air bottles.

LOCATION: Two (2) right and one (1) left

HOSE BED:

The hose bed shall be located over the booster tank, and must be accessible from the tail step and from its open top. The hose bed compartment shall have a minimum capacity of 55 cu. ft. and a minimum width of 70".

The hosebed shall have the capacity to carry the following hose:

HOSE BED DIVIDER:

One (1) divider shall be located in the hose bed. It shall be constructed of 3/16" aluminum plate. The divider shall be designed for future adjustability with locking blocks in aluminum channels at the front and the rear of the hose bed.

HOSE BED COVER:

One (1) custom tailored 22 oz. hypalon hose bed cover shall be included with the apparatus body. It shall be manufactured of a flame retardant material with a grab tensile of 480 x 500 lbs. and a tongue tear of 160 x 150 lbs. It shall be crack resistant to -40° Fahrenheit and have an adhesion lbs./in of 10.0 lbs. The hose bed cover shall be fitted to the hose bed and retained with a double woven shock cord on the front and both sides. The shock cord shall system shall utilize nylon hooks spaced every 10"-12". The cover shall be sand weighted across the rear flap and shall also include two (2) 2" wide nylon straps with teflon buckle to meet NFPA requirements.

The hosebed cover shall include a 3 year warranty.

The hypalon cover shall be red in color.

COMPARTMENTATION:

COMPARTMENT DESIGN:

The compartmentation shall be fabricated of bolted 14 gauge 304 stainless steel walls and 12 gauge 304 stainless steel floors. The compartmentation is designed to be an intricate part of the body and subframe for maximum compartment support. The compartment tops shall be fabricated of smooth stainless steel material and shall meet the intent of the latest edition of NFPA 15.7 regarding stepping, standing, and walking surfaces. The material shall be formed over each compartment top to act as drip protection over each compartment opening. The compartment flooring will be sweep out design. The front and rear corners of the body shall remain natural finish #4 stainless steel. The material be full height of the compartments and shall wrap around each corner to the compartment door frame.

The specified lighting in each compartment shall be switched automatically with the doors. The lighting shall meet the requirements of NFPA 13.10.5

HEMMED PAN STYLE DOOR CONSTRUCTION - R2

The R2 compartment doors shall be manufactured in a hemmed pan design. The perimeter of the outer pan shall be U-shaped enclosing the perimeter of the inner pan. Automotive grade adhesive shall be applied to provided structure and durability to all four (4) sides of the hem area.

Each compartment door outer and inner pan shall be manufactured of 14 gauge smooth aluminum. The door assembly shall be designed to prevent condensation buildup within the door interior. Insulation shall be installed as necessary between the inner and outer pans of each door.

Each door shall be supported with stainless steel piano hinges, 1" joint x 3/16" pin. Each hinge shall be bolted to the door perimeter and door casement with stainless steel bolts, thereby facilitating door

replacement. The door openings shall have closed cell automotive type seals to prevent water and dirt entry.

There shall be a seal applied to the outer perimeter of the door. A seal shall be provided between any double door compartments.

COMPARTMENT DOOR LATCHING:

The compartment doors shall be secured with a single point latching system. The door handle shall consist of a stainless steel rotary D-ring latch. Each latch shall connect with a pair of strikers.

NON-PAINTED ROLL-UP DOORS:

The designated compartments shall have Robinson Roll-up Shutter Doors with a satin finish. The doors shall be made of an anodized aluminum slat incorporating an exclusive seal that prohibits water intrusion, absorbs shock, eliminates clatter, and provides quiet, vibration-free performance.

TALL BOTTOM RAIL:

Each ROM door shall incorporate a tall bottom rail for improved accessibility.

COMPARTMENT VENTS:

One (1) interior vent shall be installed in the R2 compartment only. The vent shall be constructed of stainless steel and shall incorporate four (4) 5" x ¾" louvers.

LEFT SIDE BODY SHALL BE AS FOLLOWS:

L1

A roll-up door compartment assembly with a door opening of 30" wide x 61" high x 12" deep in the upper area and 26" deep in the lower area shall be incorporated on the apparatus left side ahead of the rear wheels.

The compartment shall include the following:

Unistrut Tracking

LED Krystal-Lite tube lighting to illuminate the entire area. The lights shall run the entire height of the compartment on each side of the door opening.

L2

One (1) compartment with a roll-up door shall be located above the wheel well on the left side. It shall have a door opening of 54" wide x 27" high x 12" deep.

The compartment shall include the following:

Unistrut Tracking

LED Krystal-Lite tube lighting to illuminate the entire area. The lights shall run the entire height of the compartment on each side of the door opening.

L3

A roll-up door compartment assembly with a door opening of 42" wide x 61" high x 12" deep in the upper area and 26" deep in the lower area shall be incorporated on the apparatus left side behind the rear wheels.

The L3 compartment shall extend to the rear body panel.

The compartment shall include the following:

Unistrut Tracking

LED Krystal-Lite tube lighting to illuminate the entire area. The lights shall run the entire height of the compartment on each side of the door opening.

RIGHT SIDE BODY SHALL BE AS FOLLOWS:

R1

A roll-up door compartment assembly with a door opening of 30" wide x 45" high x 12"/26" deep shall be incorporated on the apparatus right side ahead of the rear wheels.

The compartment shall include the following:

Unistrut Tracking

LED Krystal-Lite tube lighting to illuminate the entire area. The lights shall run the entire height of the

compartment on each side of the door opening.

R2

One (1) compartment with a HEMMED drop down door shall be located above the wheel well on the right side. It shall have a door opening of 56" wide x 15" high x 12" deep.

The compartment shall include the following:

Unistrut Tracking

LED Krystal-Lite tube lighting to illuminate the entire area. The lights shall run the entire height of the compartment on each side of the door opening.

R3

A roll-up door compartment assembly with a door opening of 42" wide x 45" high x 12"/26" deep shall be incorporated on the apparatus right side behind the rear wheels.

The R3 compartment shall extend to the rear body rail.

The compartment shall include the following:

Unistrut Tracking

LED Krystal-Lite tube lighting to illuminate the entire area. The lights shall run the entire height of the compartment on each side of the door opening.

REAR COMPARTMENT SHALL BE AS FOLLOWS:

A roll-up door compartment assembly with a door opening of 36" wide x 44" high x 37" deep shall be located at the rear of the apparatus.

TRANSVERSE OPENING:

The side compartments behind the wheel shall be made transverse or interconnecting with the rear compartment. This transverse compartment will be full body width and must be accessible from the left side, right side or the rear compartment area.

The rear compartment shall include the following:

LED Krystal-Lite tube lighting to illuminate the entire area. The lights shall run the entire height of the compartment on each side of the door opening.

ELECTRICALLY CONTROLLED LADDER RACK:

One (1) Ziamatic quick lift ladder system shall be installed on the apparatus. The ladder system shall be controlled from the front area of the ladder location.

ATTIC LADDER BRACKET:

One (1) attic ladder bracket shall be provided. It shall have the capacity to carry an attic ladder. Abrasion pads shall be installed to prevent body finish damage.

The ladder storage shall have the capacity to contain the following: One (1) 24' 2-section ladder, one (1) 14' roof ladder with hooks, and one (1) 10' attic ladder

The ladder rack finish shall remain as originally supplied by the Zico.

LOCATION: Right Side

RUB RAILS:

Bolt on aluminum rub rails shall be installed, below the compartment doors. Said rub rails will be fabricated of a polished "C" channel aluminum, mounted to the body surface utilizing ¼" plastic spacers. The channel designed rub rail shall incorporate a highly reflective red and white reflective stripe to aid in apparatus protection.

The rub rail on each side shall incorporate the NFPA lower zone warning lights. Each light shall be controlled from the in cab switch panel

TANK:

BOOSTER TANK:

The tank shall have a capacity of 1000 US gallons complete with a lifetime warranty. The tank manufacturer shall mark the tank and furnish notice that indicates proof of warranty. The purpose of the markings and notice is to inform department personnel who store, stock, or use the tank that the unit is under warranty. Markings may be brief but should include a short statement that a warranty exists, the substance of the warranty, its duration, and who to notify if the tank is found to be defective.

The tank shall be constructed of ½" thick PT2E polypropylene sheet stock. This material shall be non-corrosive stress relieved thermo-plastic and U.V. stabilized for maximum protection.

The booster tank shall be of a specific configuration and so designed to be completely independent of the body and compartments. All joints and seams shall be nitrogen welded and tested for maximum strength and integrity. The transverse swash partitions shall be manufactured of 3/8" PT2E polypropylene (natural in color) and extend from approximately 4" off the floor to just under the cover. The longitudinal swash partitions shall be constructed of 3/8" PT2E polypropylene (natural in color) and extend from the floor of the tank through the cover to allow for positive welding and maximum integrity.

All partitions shall be equipped with vent and air holes to permit movement of air and water between compartments. The partitions shall be designed to provide maximum water flow. All swash partitions interlock with one another and are welded to each other as well as to the walls of the tank.

FILL TOWER AND COVER

The tank will have a combination vent and manual fill tower. The fill tower will be constructed of ½" PT2E polypropylene and shall be a minimum dimension of 8" x 8" outer perimeter. The tower will be located in the left front corner of the tank. The tower will have a ¼" thick removable polypropylene screen and a PT2E polypropylene hinged type cover. Inside the fill tower, approximately 4" down from the top, shall be fastened a combination vent overflow pipe. The vent overflow shall be a minimum of schedule 40 polypropylene pipe with a minimum I.D. of 4" that is designed to run through the tank and shall be piped behind the rear wheels.

The tank cover is constructed of ½" thick PT2E polypropylene and UV stabilized, to incorporate a multi three-piece design which allows for individual removal and inspection if necessary. The tank cover will be recessed 3/8" from the top of the tank and shall be welded to both sides and longitudinal partitions for maximum integrity. Each one of the three covers will have hold-downs consisting of 2" polypropylene dowels spaced a maximum of 30" apart. These dowels will extend through the covers and be welded to the transverse partitions. This will assist in keeping the cover rigid under fast filling conditions. A minimum of two (2) lifting dowels shall be drilled and tapped ½" x 13" to accommodate the lifting eyes.

SUMP

There will be one (1) sump standard per tank. The sump shall be constructed of ½" PT2E polypropylene and be located in the left front quarter of the tank. The sump will have a minimum 3" NPT threaded outlet on the bottom for a drain plug. This shall be used as a combination cleanout and drain. All tanks shall have an anti-swirl plate located approximately 2" above the sump.

OUTLETS

There will be two (2) standard tank outlets: one for the tank to pump suction line which will be a minimum of a 3" NPT coupling and one for a tank fill line which will be a minimum of a 2" NPT coupling. All tank fill couplings will be backed with flow deflectors to break up the stream of water entering the tank, and be capable of withstanding sustained fill rates of up to 1000 GPM. All auxiliary outlets and inlets must meet all NFPA guidelines in effect at the time of manufacture.

MOUNTING

The tank shall rest on the body cross members with an unsupported area not to exceed 530 sq. inches on tanks up to 40" in height. On tanks over 40" in height, an unsupported area of not more than 400 sq. inches must be maintained. All tanks shall be isolated from the cross members through the use of hard rubber strips with a minimum thickness and width dimension of .250 x 2" and a minimum Rockwell hardness of 60 durometer. Additionally, the tank must be supported around the entire bottom outside perimeter and captured both front and rear as well as side to side to prevent the tank from shifting during vehicle operation. A picture frame type cradle mount shall be utilized with a minimum of 2" x 2" x .250 structural material.

Although the tank is designed on the free-floating suspension principle, it shall be required that the tank have hold down restraints half way between the front and the rear of the tank. These restraints shall be made of 3" x 3" x ¼" angle approximately 6" long. The restraints shall be mounted to the side walls of the hose bed and extend down so that they rest approximately ½" above the top of the tank. The tank shall be completely removable without disturbing or dismantling the apparatus structure.

Upon final apparatus delivery, proper evidence and certifications shall be presented indicating the tank has the capacity of flow to the pump 80% of its rated capacity at a flow rate of 1000 GPM.

DEMO UNIT PROVISIONS:

The tank shall include provisions as needed to accommodate a potential rear suction and one (1) rear 2½" fast fill on the right side above the suction hose storage compartment.

12 VOLT ELECTRICAL:

ELECTRICAL WARRANTY:

Alexis Fire Equipment Co., Inc. warrants each new piece of Alexis fire and rescue apparatus to be free from defects in material and workmanship under normal use and service. Our obligation under this warranty is limited to repairing or replacing, as the company may elect, any part or parts thereof which shall be returned to us with transportation charges prepaid, and as to which examination shall

disclose to the company's satisfaction to have been defective, provided that such part, or parts shall be returned to us within five (5) years or 40,000 miles after delivery of such vehicle. Such defective part or parts will be repaired or replaced free of charge and without charge for installation to the original purchaser.

Prior to any warranty work being performed on the unit, a Warranty Authorization Number must be obtained from Alexis Fire Equipment.

Items specifically covered are:

- Electrical harnesses and harness installation
- Printed circuit board
- Switches, circuit breakers and relays

Items excluded are:

- Chassis electrical systems and components installed by chassis manufacturer
- Separately manufactured items installed by Alexis Fire Equipment including, but not limited to; batteries, sirens, battery chargers, inverters, lightbars and similar equipment. (These are covered by warranties supplied by the manufacturer of the components).
- Periodic tightening and cleaning of connection terminals as this is considered routine maintenance
- Normal wear, abuse, accident, negligence or un-approved alteration of original parts.

Should repairs become necessary under the terms of this warranty, the extent of that repair shall be determined solely by Alexis Fire Equipment and shall be performed solely by Alexis Fire Equipment or a repair facility designated by Alexis. The expense of any transportation to or from such repair facility shall be that of the purchaser and is not an item covered by this warranty.

Alexis Fire Equipment reserves the un-restricted right at any time to make changes in design of and/or improvements on its products without thereby imposing any obligation on itself to make corresponding changes or improvements in or on its products theretofore manufactured.

12 VOLT ELECTRICAL SYSTEM:

Our electrical system is engineered to provide many years of dependable, trouble free service.

The 12 volt apparatus wiring shall be completely independent of the chassis electrical system. The system shall incorporate a state-of-the-art electrical distribution center. The center shall include a microprocessor, automatic reset circuit breakers, and switching relays.

The microprocessors are housed in a weather resistant enclosure. All processors are fully tested, and

modern production processes guarantee long-term reliability in the most rigorous environments. The microprocessors handle the numerous switching functions without the excessive use of relays and the need for excess wiring.

The system can be expanded by adding additional processors and required components to meet desired specifications.

The weather tight modular service center shall be placed in a water-tight compartment in the apparatus body. The service center housing shall be manufactured of aluminum and shall incorporate an access door. Since the microprocessor is of weather resistant design and enclosed in the service center, the electrical system has redundant protection against moisture and corrosion. Redundant protection from the elements dramatically improves reliability and durability.

Wiring harnesses shall be custom made for each truck. Each harness shall be encased in a split barrel, nylon type loom which will be moisture resistant and flame resistant to a minimum of 280° F. Loop outs shall be made at the harness factory utilizing sealed sonic weld technology instead of open-ended butt splicing. The harnesses shall feature Deutsch heavy duty all metal connectors.

Unlike terminal strips, binding post and other open-wiring systems, the Deutsch HD series is a completely sealed unit. The elimination of open wiring systems does away with contamination from moisture, dust, lubricating oils, road salt, and other environmental hazards encountered in heavy duty use. The connector shall provide a multiple keying system that positively prevents mis-mating and makes plug/receptacle coupling quick and easy. The modular harness system will allow for quick and efficient complete body transfer if needed.

An independent switching station shall be centrally located in the apparatus cab. The switches shall be of a rocker type illuminating design. Each switch shall be color coded, and include a description indicating its intended use. Each switch shall be removable for service and replacement. Each switch shall be rated at 10 amp at 250 volts AC and shall act as inputs for the microprocessor.

All electrical circuit feeder wiring supplied and installed by the apparatus manufacturer shall be stranded copper alloy conductors of a gauge rated to carry 125% of the maximum current for which the circuit is protected. Insulation shall be in accordance with SAE J1128, low tension primary cable, type SXL or GXL, and wired to SAE J1292, automobile, truck, truck-tractor, trailer and motor coach wiring, for such loading as the potential employed. Voltage drops in all wiring from the power source to the using device shall not exceed 10%. Overall covering of conductors shall be 280° F (143° C) minimum flame retardant, moisture resistant loom or braid. All connections shall be made with lugs or terminals mechanically secured to the conductors. Wiring shall be thoroughly secured in place and suitably protected against heat, oil, and physical damage. Wiring shall be color coded and printed with a circuit function code over each conductor's entire length.

Circuits shall be provided with properly rated low voltage over-current protective devices. Such devices shall be readily accessible and protected against excessive heat, physical damage and water spray, switches relays, terminals, and connectors shall have a direct current rating of 125% of maximum current for which the circuit is protected.

Wiring Diagrams: Two (2) destination effective wiring diagrams shall be furnished with the apparatus. The wiring diagrams shall incorporate notations to assist an individual with limited electrical experience in the service of the apparatus electrical system.

NOTE: All wiring and components shall meet or exceed current N.F.P.A. codes.

LOAD MANAGEMENT:

The 12 volt load management functions shall be incorporated within the microprocessor based 12 Volt electrical system without the need for a separate load manager.

ELECTRICAL SYSTEM PERFORMANCE TESTS:

The apparatus low voltage electrical system shall be tested and certified per the current NFPA standard. The certification shall be delivered to the purchaser with the apparatus.

DOCUMENTATION:

At the time of delivery, the manufacturer shall provide the following:

- (a) Documentation of the electrical system performance tests;
- (b) A written load analysis, including:
 - 1. The nameplate rating of the alternator;
 - 2. The alternator rating;
 - 3. Each component load comprising the minimum continuous load;
 - 4. Additional loads that, when added to the minimum continuous load, determine the total connected load;
 - 5. Each individual intermittent load.

RADIO:

One (1) radio(s) shall be installed by the customer after receipt of the completed apparatus.

OPTICAL WARNING SYSTEM:

The optical warning system on the fire apparatus shall be capable of two separate signaling modes during emergency operations. One mode shall signal to drivers and pedestrians that the apparatus is responding to an emergency and is calling for the right-of-way. The other mode shall signal that the apparatus is stopped and is blocking the right-of-way.

EMERGENCY WARNING LIGHTS:

For the purpose of defining and measuring the required optical performance, the apparatus shall be divided into four warning zones. The four zones shall be determined by drawing lines through the geometric center of the apparatus at 45° to a line lengthwise of the apparatus through the geometric center. The four zones shall be designated A, B, C, and D in a clockwise direction with zone A at the front of the apparatus. Each zone shall have an upper and lower warning level.

Effective coverage of all four zones, both upper and lower, as required by the latest NFPA Edition shall be provided.

LIGHTBAR:

One (1) Code-3 69" LED lightbar, Model 21TR69JKA1, shall be mounted on the cab roof. The lightbar shall be switched from the in cab switch panel. This lightbar fills the requirements of Zone A Upper, Zone B Upper, and Zone D Upper.

WARNING LIGHTS (REAR):

Two (2) Code-3 Arch LSS222 red LED beacons shall be mounted on the upper rear area of the vehicle. These beacons shall be switched from the in cab switch panel. These lights fill the requirements of Zone C Upper, Zone B Upper, and Zone D Upper.

WARNING LIGHTS (REAR LOWER):

Two (2) Code-3 Model TRX6R red LED lights shall be mounted on the lower rear area of the vehicle. The lights shall be placed inside chrome flanges. These lights shall be switched from the in cab switch panel. These lights fill the requirements of Zone A Lower.

REAR DRIVING SIGNALS:

The rear driving signals shall consist of two (2) Code 3 7X9STTRBZ LED lights, one (1) each side of the apparatus at the rear. The 7X9 LED lights shall incorporate red brake/tail, amber turn, and white

backup in a single light head. The mounting shall include a chrome bezel.

TURN SIGNALS-MIDSHIP:

One (1) S34 Series amber LED midship turn light shall be mounted on each side of the apparatus ahead of the rear wheels.

ICC LIGHTING:

Tecniq S34 Series LED Clearance lights shall be installed on the apparatus. They shall be hermetically sealed cartridge lights for ease of service and durability.

PUMP COMPARTMENT LIGHT:

One (1) 5" T41 Series LED light shall be installed in the pump compartment. The light shall be switched with pump panel lights.

HAZARD LIGHT:

A red, LED flashing light located in the driving compartment shall be illuminated automatically whenever the apparatus parking brake is not fully engaged and any passenger or equipment compartment door is open, any ladder or equipment rack is not in the stowed position, a stabilizer system is deployed, a powered light tower is extended, or any other device is opened, extended, or deployed that creates a hazard or is likely to cause damage to the apparatus if the apparatus is moved. The light shall be marked "Do Not Move Apparatus When Light Is On".

LED COURTESY LIGHTS (UNDER CARRIAGE LIGHTING):

A 5" 12-volt T41 Series LED light shall be located under each area designed for personnel to climb onto the apparatus or descend from the apparatus to the ground level. All ground area lighting shall be controlled by the master switch and shall be switched with the parking brake.

LED TAILBOARD COURTESY LIGHTS:

Two (2) S34 Series LED courtesy lights shall be mounted one (1) each side low on the rear panel. The lights shall illuminate the rear tailboard. They shall be switched with the parking brake.

LED RUNNING BOARD COURTESY LIGHTS:

One (1) S34 Series LED courtesy light shall be mounted on each side low on the pump module. Each

light shall illuminate the running board area. The lights shall be switched with the parking brake.

SCENE LIGHTS:

One (1) Fire Research Spectra LED Flood and Loading Light model SPA900-Q70 surface mount light shall be installed. The light shall be mounted with four (4) screws to a flat surface. It shall be 6 3/4" high by 9" wide and have a profile of less than 1 3/4" beyond the mounting surface. Wiring shall extend from a weatherproof strain relief at the rear of the lamphead.

The light shall have twenty-four (24) white LEDs. It shall operate at 12/24 volts DC, draw 6/3 amps and generate 7000 lumens of light. The lens shall redirect the light along the vehicle and out onto the working area. The lamphead housing shall be aluminum with a chrome colored bezel.

The light(s) shall be switched from the cab console.

LOCATION: Rear left side

TELESCOPIC LED FLOODLIGHT

Two (2) Fire Research Spectra LED Scene Light model SPA530-Q20 side mount push up telescopic light shall be installed. The light pole shall be anodized aluminum and have a knurled twist lock mechanism to secure the extension pole in position. The extension pole shall rotate 360 degrees. The outer pole shall be a grooved aluminum extrusion and qualify as an NFPA compliant handrail. The pole mounting brackets shall have a 2 3/4" offset. Wiring shall extend from the pole bottom with a 4' retractile cord.

The lamphead shall have eighty four (84) ultra-bright white LEDs, 72 for flood lighting and 12 to provide a spot light beam pattern. It shall operate at 12/24 volts DC, draw 18/9 amps, and generate 20,000 lumens of light. The lamphead shall have a unique lens that directs flood lighting onto the work area and focuses the spot light beam into the distance. The lamphead angle of elevation shall be adjustable at a pivot in the mounting arm and the position locked with a round knurled locking knob. The lamphead shall be no more than 5 7/8" high by 14" wide by 3 1/2" deep and have a heat resistant handle. The lamphead and mounting arm shall be powder coated. The LED scene light shall be for fire service use.

The lights shall be individually switched from the in cab switch panel.

LOCATION: One (1) each side of the pump panel

HOSEBED BULKHEAD LIGHTING - LED:

Three (3) 5" LED 12-volt lights, T41 Series, shall be located in the front bulkhead of the apparatus hose bed, below the body decking. Each light shall be rubber grommet mounted and shall be recessed in the upper front wall. Each light shall be switched with the parking brake.

BRACKETING:

FOLDING STEP(S):

Three (3) large folding step(s) shall be furnished on the apparatus. Each step shall be mounted in the specified location.

LOCATION: Rear left side

INTERMEDIATE REAR STEP:

An intermediate rear step constructed of 1/8" grip strut shall be located at the rear of the apparatus between the rear step and the body hose bed. The step shall be 8" deep and shall be body width.

INTERMEDIATE WALKWAY STEP:

An intermediate step constructed of 3/16" aluminum treadplate shall be located on each side of the apparatus at the walkway, between the top of the walkway and the running board. The step shall be 8" deep x 12" wide.

GRAB HANDLES:

Two (2) 58" knurled bright stainless steel 1¼" O.D. grab rails shall be installed on the rear radius of the body panels.

GRAB HANDLE:

One (1) 58" knurled bright stainless steel 1¼" O.D. grab rail shall be installed horizontally below the apparatus hose bed.

HARD SUCTION STORAGE COMPARTMENT:

One (1) hard suction hose storage compartments shall be designed into the rear of the apparatus. The hose shall be accessible from the rear of the apparatus below the tank "T". The compartments shall

incorporate a hinged door with latch. The door shall be manufactured of the same material as the rear body panel and finished to match (treadplate, painted, chevron, etc.) The compartment shall have the capacity to carry two (2) lengths of suction hose with one (1) preconnected low level strainer.

LOCATION: Right Side

WHEEL CHOCKS:

One (1) pair of Worden Safety Model 211001 one-piece rubber wheel chocks shall be provided with the apparatus. Each chock features a molded in grab handle, an elbow fixture for rope or chain attachment, and utilizes a very sticky live rubber to ensure high coefficient of friction.

FINISH:

APPARATUS BODY FINISH:

The final finish of the apparatus shall conform to fire apparatus standards, exhibiting excellent gloss durability and color retention properties.

PREPARATION:

Since the removal of all contaminants and oxidation is essential to the final effect of a finish system, the apparatus shall be pre-cleaned with wax and grease remover and towel dried prior to evaporation.

A 10-step standard body preparation shall be completed.

When the substrate is prepared, the entire body shall be cleaned by washing again with wax and grease remover and towel dried.

PRETREAT AND PRIMERS:

The pretreat and primer applications shall be made in two (2) independent steps. A application of a combined pretreat/primer product will not be allowed as a substitute.

The prepared substrate shall be pretreated with Acid Curing 2 Component Transparent Primer. This pretreat shall be designed to provide corrosion protection and to create an adhesive bond between the substrate and the surface applications.

To enhance adhesion and top coat gloss, a 2 component epoxy primer shall be applied.

All the primed surfaces shall be sanded smooth, thus removing all texture and surface imperfections and creating a finish base that will meet the rigid requirements of the fire and emergency services.

TOP COATS:

Two (2) coats (0.5 - 2.0 mils) urethane base coat shall be applied in a professional manner. After the base coats have cured properly, two (2) coats of a high solids urethane clear coat shall be applied.

All surface imperfections shall be removed by buffing and polishing.

PAINT WARRANTY:

The apparatus shall be covered by a seven- (7) year paint warranty. Following are the covered defects and exclusions.

Covered Defects shall include only the following list of defects:

- Peeling or delaminating of the topcoat and/or other layers of paint.
- Cracking or checking.
- Loss of gloss caused by cracking, checking or hazing.

Defects resulting from the following conditions are excluded from the Warranty:

- Hazing, chalking or loss of gloss caused by improper care, abrasive polishes, cleaning agents, heavy-duty pressure washing, or aggressive mechanical wash systems
- Rock chips are not covered under this warranty.
- Paint deteriorating caused by abuse, scratches, chips, gloss reduction, accidents, acid rain, chemical fallout or acts of nature
- Claims presented without proper Warranty documentation
- Failure on finishes performed by Non-PPG Commercial Certified Technicians
- Failures on finishes due to inadequate film builds
- Failures due to improper cleaning or surface preparation or failure to follow the product use instructions

The hose bed interior walls shall remain natural finish.

COMPARTMENT INTERIOR FINISH:

The interior of the compartments shall be natural finish stainless steel

APPARATUS COLOR:

The color of the apparatus shall be as follows:

COLOR: _____

CAB LETTERING:

Vinyl lettering as described below shall be applied to the chassis cab door, one (1) each side. Each letter shall be 2½" to 3½" high and hand applied.

Vinyl letters/numbers shall be applied to the chassis cab fender area, one (1) each side. Each letter/number shall be 2½" to 3½" high and hand applied.

The lettering vinyl style shall be simulated gold leaf.

The lettering font style shall be Eurostile Bold.

The lettering font highlight type shall be shadow.

LAMINATION WARRANTY:

The apparatus shall be covered by a three (3) year warranty against defects in material and workmanship with the graphics process

REFLECTIVE STRIPING:

The finished apparatus shall be striped white with 6" reflective Scotchlite striping.

DIAMOND GRADE CHEVRON STRIPING:

The rear of the apparatus shall be striped with Diamond Grade retro-reflective striping. The striping shall be applied in a chevron pattern sloping downward and away from the centerline of the apparatus at a 45° angle. The striping shall be single color alternating between red #3992 and fluorescent yellow-green #3983.

The striping shall be applied in the following locations: vertical surfaces between the body panels at the rear, from the tailstep walkway to the hose bed

EQUIPMENT:

One (1) Duo-Safety #10-585A aluminum folding 10' attic ladder(s).

One (1) Duo-Safety 14-775A, 14' Roof Ladder(s) with hooks.

One (1) Duo-Safety #24-900A, 24' 2 Section ground ladder(s).

Two (2) 10' Length(s) of 6" diameter hard suction hose, coupled 6" LHF x 6" RLM. (Not rated for hydrants)

NFPA EQUIPMENT CLARIFICATION:

Any equipment specified in the "Minor Equipment" section (e.g. hose, nozzles, adapters, AED, traffic cones, traffic safety vests, etc.) of NFPA 1901 for each apparatus classification (see below) which is not specified in this proposal shall be considered to be customer supplied and installed.

| Apparatus Type | NFPA Section |
|---------------------|--------------|
| Pumper | 5.8 |
| Initial Attack | 6.7 |
| Mobile Water Supply | 7.7 |
| Aerial | 8.8 |
| Quint | 9.8 |
| Special Service | 10.5 |
| Mobile Foam | 11.9 |

NFPA 1901-2009

The National Fire Protection Association "Standard for Automotive Fire Apparatus, 2009 Edition, is hereby adopted and made a part of these specifications for the componentry supplied in the incomplete chassis.

CUSTOM FIRETRUCK CHASSIS

The chassis shall be designed and manufactured by a custom chassis manufacturer. The manufacturer shall demonstrate evidence of manufacturing similar custom vehicles for at least fifty (50) years.

The chassis shall be designed and manufactured for heavy duty fire service with adequate strength and capacity for all components as detailed within these specifications.

CHASSIS FRAME

The frame shall be designed to industry standards. The manufacturer shall provide a life time frame side rail warranty to the original purchaser of the chassis. The frame rails shall be 10.5" x 3.5" x .375" heat treated steel.

A 3/4 length inner frame side rail liner with dimensions of 9.687" x 3.125" x .3125" shall be provided for additional strength and reduce deflection. The frame liner shall extend from the centerline of the front axle and taper 45 degrees forward and shall extend to the rear of the main frame rail.

The frame side rails shall be 110,000 psi minimum yield and shall have a minimum section modulus of 30.38 cu. in., in the frame liner area, calculated by using the square corner shape method. The resulting frame rail resistance to bending moment shall be 3,341,800 in. lb. per rail.

To insure the maximum clamp load for the fastener prevailing torque the crossmembers shall be bolted in place using grade 8 bolts, hardened washers, and grade "C" distorted thread locknuts. Flanged head fasteners shall not be acceptable. The top of the frame rails shall be free of bolt heads.

Frame engine cutouts shall be made with a plasma torch to minimize the heat affected zone of the cut. All cutouts shall have a minimum of 6 inch transitions between rail flange cut depths to reduce the stress concentrations throughout the cutout area. The root of all transition areas shall have a minimum of a 2 inch radius to reduce stress concentrations at the root.

The main frame rails, frame liner and main frame crossmembers behind the pump shall be galvanized to reduce the effect of harsh road chemicals. This warranty shall be in effect for 20 years after delivery of the apparatus to the end user.

CAB MAIN FRAME CROSSMEMBER

In addition to the rear cab support crossmember there shall be a main frame cross member mounted in the rear cab area. This cross member shall be a wide base flanged design to provide frame spacing and excellent strength to prevent frame paralleling. Every frame cross member shall be bolted in place using grade 8 bolts, hardened washers, and grade "C" distorted thread locknuts.

FRONT AXLE

The front axle shall be a MERITOR model "MFS-18-133A-N" with a 18,740 lb. capacity.

CRAMP ANGLE

The chassis shall have a turning cramp angle of 45-degrees. Both left and right turns have a full 45° cramp angle with tires and wheels mounted on the axle and installed in the chassis. The 45° cramp angle is achieved irrespective of options such as front suctions and disc brakes.

FRONT AXLE OIL SEALS

The front axle shall be equipped with oil bath type oil seals as supplied on the axle from the axle manufacturer. The spindles shall be equipped with transparent covers for oil level inspection.

FRONT AXLE BRAKES

The front brakes shall be Cam-Master Q Plus, 16-1/2" X 6" (419 x 152), S-Cam, air operated heavy duty brakes for increased stopping power and brake life in severe braking applications.

The "S" cam brakes shall incorporate a double anchor pin design, for stability and smooth consistent stopping. The camshafts shall be heat treated with rolled spline construction.

The front axle shall be equipped with automatic slack adjusters (ASA) to provide optimum brake performance.

FRONT SUSPENSION

The front suspension shall be a pin and shackle design. Front springs shall be a minimum of ten (10) leaf elliptical type, 53" x 3-1/2" x .499" forged steel. The front springs shall have a military wrapper for safe operation. For a smooth ride the spring rate shall not exceed 3,000 lbs/in deflection.

All front spring pins shall be ground heat treated steel with grease fittings for lubrication.

The entire front suspension shall be designed for heavy duty custom fire apparatus with a capacity at ground of 18,740 lbs.

Double acting hydraulic shock absorbers are to be installed.

STEERING SYSTEM

The steering shall be equipped with a single SHEPPARD M110 integral power steering gear. The engine shall be equipped with a gear driven pump.

A remote steel reservoir shall be provided with the ability to check the fluid level when the cab is in the lowered position.

FRONT TIRES

The front tires shall be 385/65R22.5-18PR (J) GOODYEAR G-296 MSA tread, tubeless radial tires. These tires shall be mounted on 22.5" x 12.25" rims.

INTERMITTENT* SERVICE LOAD RATING

The front axle GAWR using these tires shall be 20,050 lbs. @ 120 psi.

*Intermittent Service use is defined as no more than 50 miles of continuous operation under maximum recommended payload at the maximum speed. If it is necessary to operate continuously for more than 50 miles without stopping for at least 20 minutes, the emergency vehicle must reduce its speed to no more than 50 mph after the first 50 miles of travel.

TIRE SPEED RATING

The maximum tire speed rating is 68 MPH.

ALUMINUM WHEELS

Two (2) polished aluminum wheels shall be supplied and installed on the front axle. The 22.5" x 12.25" wheels shall be highly polished on the outboard side.

SINGLE REAR AXLE

The rear axle shall be a MERITOR model "RS-25-160" with a 27,000# capacity for the fire service.

MERITOR DIFFERENTIAL

The rear axle shall contain a Meritor 160 Series differential with an 18 inch diameter ring gear utilizing hypoid-Generoid gearing and a 2-1/4 inch diameter axle shaft.

AXLE DIFFERENTIAL LUBE

The axle shall have the initial factory fill made with non-synthetic axle lube meeting the axle manufacturer's recommendations.

REAR AXLE OIL SEALS

The rear axle shall be equipped with premium oil bath type oil seals as supplied on the axle from the axle manufacturer.

REAR AXLE BRAKES

The rear brakes shall be Cam type, 16-1/2" X 7" (419 x 178), S-Cam, air operated heavy duty brakes for increased stopping power and brake life in severe braking applications.

The "S" cam brakes shall incorporate a double anchor pin design, for stability and smooth consistent stopping. The camshafts shall be heat treated with rolled spline construction.

The rear axle shall be equipped with automatic slack adjusters (ASA) to provide optimum brake performance.

VEHICLE TOP SPEED

The rear axle shall be geared for a top speed of 65 to 68 mph at engine governed RPM.

NFPA TOP SPEED STATEMENT

NFPA-1901, 2009 Edition - 4.15.2 The maximum top speed of fire apparatus with a GVWR over 26,000 lb (11,800 kg) shall not exceed either 68 MPH (105 km/hr) or the manufacturer's maximum fire service speed rating for the tires installed on the apparatus, whichever is lower.

NFPA-1901, 2009 Edition - 4.15.3 If the combined water tank and foam agent tank capacities on the fire apparatus exceed 1250 gal (4732 L), or the GVWR of the vehicle is over 50,000 lb (22,680 kg), the maximum top speed of the apparatus shall not exceed either 60 MPH (105 km/hr) or the manufacturer's maximum fire service speed rating for the tires installed on the apparatus, whichever is lower.

The speed selected on this apparatus exceeds 60 MPH (105 km/hr) and the customer is aware of NFPA-1901 and the top speed that will be achieved with the finished apparatus.

SINGLE AXLE REAR SUSPENSION

The rear springs shall be a minimum of seventeen (17) main including four (4) auxiliary leaves. The rear suspension shall have a rating of 27,000 lbs. Capacity. The rear suspension shall be a "self-leveling" slipper type with a main torque leaf that contains a military wrapper. The torque leaf shall contain a bronze bushing for long service life.

The rear hangers are to be of the slipper design. For a smooth ride the rear suspension deflection rate shall not exceed 3,790 lbs. per inch.

One (1) inch diameter rear suspension U-bolts are required.

Two (2) main frame cross members shall be mounted in the rear suspension area, bolted to the frame rail as a rear suspension support member. Each cross member shall be a wide base flanged design to provide frame spacing and excellent strength to prevent frame paralleling. Each cross member shall be bolted in place using grade 8 bolts, hardened washers, and grade "C" distorted thread locknuts.

AIR SYSTEM

An air brake system meeting the requirements of the FMVSS-121 shall be provided. The system shall consist of three (3) reservoirs with a 4,362 cu. in. volume. The air system shall consist of the following components:

Dual air system with dual gauges and a warning light and buzzer. A spring actuated parking brake built into the rear axle brakes with a manual control and warning light in the cab. These shall automatically apply in case of air system failure. A mechanical means of releasing the spring brake shall be provided in the event of total loss of air pressure.

A quick build up system shall be provided, capable of building enough air pressure to release the spring brake in less than thirty (30) seconds, when starting with the entire air system at zero pounds pressure.

The brake system shall be a split system. One (1) system serving the rear brakes and one (1) system serving the front brakes. The two (2) systems shall be connected with a double check valve that shall automatically shuttle air from the front system to the rear system should loss of air pressure occur. This system shall also modulate the amount of air so the spring brakes shall apply in direct relationship to the amount of pressure applied to the treadle valve.

The brake system shall be equipped with a Bendix SR-7 valve to provide modulated spring brakes in the event there is low air pressure in the rear axle air supply reservoir.

The spring brakes shall be piped in such a manner that if the treadle valve is depressed while the spring brakes are applied, the spring brakes shall release and remain released as long as the treadle valve is depressed. They shall reapply immediately when the treadle valve is released.

The piping in the air system shall be 2-ply nylon reinforced color coded tubing for all stationary lines.

AIR DRYER

The air system shall include a BENDIX AD-SP air dryer.

The air dryer shall have a spin off desiccant cartridge.

The air dryer shall incorporate an integral turbo cutoff valve. The turbo cutoff valve shall close the path between the air compressor and the air dryer purge valve during the compressor "unload" cycle. This shall allow the air dryer to purge the water and contaminants without any loss of turbo boost or engine horsepower.

A 12 volt heated moisture ejector shall be an integral part of the air dryer. This heater shall be thermo- statically controlled. The electrical connection for the heater shall use a sealed electrical connector to protect against moisture and corrosion.

DEDICATED AIR HORN RESERVOIR

One (1) 2181 cu. in. additional reservoir shall be connected to the chassis air system to provide an air supply for

the chassis air horns. This reservoir shall include a pressure protection valve on the inlet side to allow full use of this tank without draining air from the chassis air system.

MANUAL AIR TANK DRAINS

All air reservoirs shall have manual 1/4 turn drain valves. The drain valves shall be supplied with rubber seats to reduce air system leaks. The reservoir drain valves shall allow the accumulation of contaminants that are collected in the reservoirs to be drained off to the atmosphere.

MERITOR/ROCKWELL/WABCO ABS BRAKE SYSTEM

A four channel, single rear axle model, MERITOR/ROCKWELL/WABCO ABS Braking System shall be supplied.

A frame mounted electronic control unit (ECU) shall monitor and control wheel speed during braking. Wheel sensors, constantly monitoring wheel speed, send information to the ECU. If a wheel begins to lock the ECU transmits an electrical impulse to modulator valves that can apply, release or hold the air pressure in the brake chambers. The rapid modulation of air pressure prevents wheel lock-up and increases driver control.

This ABS system shall be a 4S/4M system with four (4) wheel speed sensors and four (4) modulator valves.

If a fault occurs in one wheel, that wheel shall have normal (non-ABS) brake function. The other wheels shall continue to provide the ABS function. If the ABS system should fail completely, the brake control shall be returned to normal (non-ABS) braking.

An ABS warning light shall be installed on the driver's dash message center. This warning light shall cycle through a test stage at the point of ignition turn on and remain illuminated until the vehicle reaches approximately four (4) MPH. The light shall illuminate in other conditions to warn of an ABS system failure and shall illuminate when the diagnostic function is activated.

REAR TIRES

The rear tires shall be 12R22.5-16PR (H) GOODYEAR UNISTEEL G182 RSD traction tread, tubeless radial tires. These tires shall be mounted on 22.5" x 8.25" rims.

Single rear axle GAWR using these tires shall be 27,000 lbs. @ 120 psi.

TIRE SPEED RATING

The maximum tire speed rating is 75 MPH.

ALUMINUM WHEELS

Two (2) polished aluminum wheels shall be supplied in the outer wheel position of the rear axle. The 22.5" x 8.25"

wheels shall be highly polished on the outboard side.

LASER ALIGNMENT

The chassis shall have a laser alignment performed at the factory before delivery.

Toe In Front Axle - The toe in on a vehicle is set to reduce tire wear and to insure that the vehicle shall steer in a straight line. Toe in measurements are set to a positive 2.5 millimeters total, giving the vehicle 1.25 millimeters from side to side.

Toe In Rear Axle - The toe in on the rear wheels is set up slightly different in that the axle and wheels are set to ride the "crown" of the road. This is achieved by adjusting the toe to a measurement of no less than 1 millimeter, but no more than 2 millimeters. The ideal measurement is 1.5 millimeters total for both sides.

Cramp Angle - Cramp angle is set to achieve the greatest turning radius possible with the selected components of the vehicle. Each front wheel is set to zero degrees. The wheel is then turned until it reaches the steering stops. This measurement is the cramp angle.

TIRE PRESSURE MONITORING DEVICE

Each tire installed on the apparatus shall be equipped with a tire pressure monitoring device. The device shall consist of a valve stem cap to with an LED tire alert to indicate tire pressure conditions. The LED will flash when the tire drops 8 psi below the factory setting.

DIESEL ENGINE

The chassis shall be powered by a Cummins diesel engine as described below:

| | |
|----------------------|-------------------------------------|
| MODEL: | ISL9-450 |
| NUMBER OF CYLINDERS: | Six |
| BORE AND STROKE: | 4.49 in (114 mm) x 5.69 in (145 mm) |
| DISPLACEMENT: | 543 cu. in. (8.9L) |
| RATED BHP: | 450 hp (336 kW) @ 2100 RPM |
| TORQUE: | 1250 lb-ft (1696 N-m) @ 1400 RPM |
| COMPRESSION RATIO: | 16.6:1 |
| GOVERNED RPM: | 2200 |

Standard Equipment on the engine to include the following:

| | |
|------------------|--|
| OIL FILTER: | A full flow / by-pass combination |
| LUBE OIL COOLER: | High efficiency non-drainback full flow cooling |
| FUEL FILTERS: | Two fuel filters providing 3 / 10 micron absolute filtration |
| STARTER: | 12 volt |
| AIR COMPRESSOR: | A Wabco 18.7 cfm compressor shall be provided |

ENGINE COOLANT RADIATOR

The engine coolant radiator shall have sufficient capacity to perform under the engine manufacturer installation requirements. The chassis manufacturer shall demonstrate the ability to meet this requirement with the submittal of an approved IQA to the fire department for the apparatus.

This radiator shall have HRPOS top and bottom tanks. These tanks shall have a material thickness of 11 gauge. The top and bottom tanks shall be attached to the header assemblies with a minimum of forty (40) fasteners. These fasteners shall not exceed a center distance of 1.938 inches to reduce the possibility of tank leaks. These fasteners shall be torqued to a value of 29.5 ft-lbs.

The header plates shall be made of 16 gauge brass.

The radiator tubes shall be constructed of .0066 inch thick brass and have a dimensional size of .076 inch x .625 inch. These radiator tubes shall have welded tube seams.

The radiator shall contain three (3) rows of tubes arranged in an inline profile across the radiator core. The entire radiator shall contain (231) tubes. These tubes shall have a smooth bore to allow for radiator cleaning.

In the critically stressed area, where the radiator tubes are attached to the header plates, this joint shall be accomplished with a welding process on the coolant side. In addition to the welded joint a solder fillet joint shall occur on the air side of the core creating a continuous dual bond.

The radiator shall have a louvered serpentine type core that contains fins constructed of .0024 inch thick copper. These fins shall be spaced to a maximum density of 14 fins per inch of radiator tube. Each fin shall have a louvered surface for high cooling efficiency.

The radiator shall contain an integral coolant de-aeration tank. This tank shall be designed to remove entrapped air or gas from the coolant side of the radiator.

The radiator side rails shall have integrally designed support gussets for the transition to the header attachment.

The bottom tank of the radiator shall have a drain valve for coolant removal.

The bottom tank of the radiator shall have a transmission cooler with a plate-type design. The plates shall have internal turbulators to break up laminar oil flow across the surface. The cooler shall have 1311 square inches of surface area for water surface contact and heat transfer.

The radiator system shall be pressurized with a cap rated per the cooling system requirements of the specific engine manufacturer.

The high efficiency engine fan shall be encompassed with a radiator shroud to provide the proper air flow from the fan blade to the radiator.

The perimeter of the radiator shall have recirculation baffles to eliminate the possibility of recirculation of "hot" air to the face of the radiator core. The bottom of the radiator shall have a recirculation baffle from the radiator to the frame rails.

COOLANT RECOVERY SYSTEM

A coolant recovery system shall be installed on the chassis. This tank is designed to capture coolant overflow when the engine coolant warms and expands. As the engine cools the overflow is then pulled out of the tank and back into the radiator, thus maintaining proper coolant levels.

CHARGE AIR COOLER RADIATOR

The engine charge-air cooler shall have sufficient capacity to perform under the engine manufacturers installation requirements. The chassis manufacturer shall demonstrate the ability to meet this requirement with the submittal of an approved EPQ to the fire department for the apparatus.

This radiator shall have cast aluminum side tanks. These tanks shall have a material thickness of .200. These tanks shall be attached to the charge-air core with the ALBRAZE construction technique.

The external air fins shall be louvered serpentine and constructed of .006 inch thick aluminum.

The internal air fins shall be of the lance-and-offset design for greater air turbulence and higher efficiency. The internal fins are to be constructed of .010 inch thick aluminum.

The charge-air cooler shall be mounted directly in front of the engine coolant radiator. To reduce vibration rubber "iso" mounts shall be used for mounting of the charge-air cooler to the engine radiator.

The charge air cooler shall contain (12) rows of internal fins within a .313 x 2.632 aluminum tube assembly. This tube assembly shall be constructed of .025 thick aluminum.

The charge-air cooler shall contain thermal expansion slots to allow the expansion and contraction of the charge-air core over the wide range of temperatures that are expected in operation.

The charge air piping between the engine and charge-air cooler shall be aluminum tubing with a wall thickness of .065 inch. The system shall utilize four (4) ply silicone rubber woven Nomex hoses with stainless steel pressure bands. These bands are designed to maintain the hose shape under the pressure of the turbocharger boost air. All clamps used on the charge air piping are to be stainless steel constant torque and shall be installed at each joint.

COOLANT

The coolant system shall contain an ethylene glycol and water mixture to keep the coolant from freezing to a

temperature of -34 degrees F.

COOLANT HOSES

The entire chassis cooling system shall have premium rubber hoses. All clamps to be stainless steel worm drive type clamps.

COOLANT SYSTEM CLAMPS

Single wire constant torque clamps shall be used for all cooling system hoses.

HEATER LINE SHUT OFF VALVES

The heater circuit shall have quarter turn shut off valves installed on both the supply and return lines to allow a complete shut off of coolant flow to the cab heaters in hot seasons of the year. These valves shall be installed in addition to the valves in the heater unit(s).

ENGINE AIR INTAKE FILTER

The engine shall be equipped with a K&N heavy duty washable intake air filter. The filter shall utilize a media that does not require oil.

ENGINE OIL

The engine shall have the initial factory fill made with a non-synthetic engine oil meeting the engine manufacturer's recommendations.

ENGINE BRAKE

A "JACOBS" Engine Brake shall be supplied.

The Driver's dash shall include an engine brake control switch.

Activation of the engine brake shall occur at zero throttle position. The transmission ECU shall be programmed to operate in the pre-select downshift mode to maximize the retarding power of the engine brake.

The brake lights shall illuminate when the Jacobs Brake is in operation.

The Jacobs Brake shall be inoperative when the chassis is in pump mode.

The "JACOBS" engine brake shall be covered under the standard five year Cummins engine warranty.

ENGINE FAST (HIGH) IDLE

The chassis shall be equipped with an Electronic Idle Control (EIC) for the electronic engine. Preset speed is factory adjustable.

The fast idle provision shall only function when the parking brake is set and the transmission is in neutral. Manual selection of the fast idle shall be controlled by a driver's momentary switch.

Automatic activation of the fast idle shall occur when a low voltage condition exists, the truck is in neutral and the parking brakes are applied.

Cancellation of the fast idle shall be achieved by resetting the manual switch or by depressing the service brake pedal.

CORROSION INHIBITOR

Corrosion inhibitor shall be provided as an additive to the chassis cooling system.

AUXILIARY ENGINE COOLER

The cooling system shall have one (1) SENDURE auxiliary engine cooler mounted in the upper radiator water pipe. The apparatus shall have the fire pump water circulated to the cooler from a valve located on the apparatus pump panel.

SPARK ARRESTOR

A spark arrestor shall be installed in the chassis air intake system. This arrestor shall be mounted behind the intake grille to filter out airborne embers.

FAN DRIVE

A fully variable fan drive system shall be installed on the engine. Variable operation is required to reduce fan noise and improve response time and lower off-speed for maximum efficiency.

EXHAUST SYSTEM

A single exhaust pipe shall be provided for the engine. The exhaust pipe shall be supplied with a heat wrap. The wrap shall extend from the engine turbo charger to just below the frame rail.

The exhaust tubing from the turbocharger to the exhaust after treatment device shall be stainless steel.

CUMMINS AFTERTREATMENT SYSTEM

The chassis shall be equipped with a Cummins exhaust after treatment system in compliance with EPA 2010.

TAILPIPE

The tailpipe shall extend from the exhaust muffler/aftertreatment device to the rear of the vehicle making a 90° bend to exit the vehicle ahead of the rear tires on the curbside of the vehicle. The end of the pipe shall be cut square or perpendicular to the exhaust pipe centerline.

The pipe shall be unpolished stainless steel.

An exhaust gas diffuser shall be furnished on the end of the tailpipe.

DIESEL EXHAUST FLUID SYSTEM

The chassis shall be equipped with a 5 gallon Shaw Development Diesel Exhaust Fluid (DEF) reservoir system. The reservoir shall contain an Multifunctional Head Unit (MFHU) that contains integrated level and temperature sensors. The MFHU also shall contain a coolant powered heater to thaw DEF in conditions below 12°F (-11°C) to meet governmental regulations. The reservoir shall be located on the left frame rail behind the front axle beneath the cab. The mounting system shall use stainless steel mounting brackets to reduce the possibility of corrosion.

TRANSMISSION

The transmission shall be an Allison 3000EVS automatic transmission with electronic controls.

The transmission shall be equipped with a lock-up control circuit that shall automatically shift the transmission into 4th gear lock-up when the pump is shifted into gear.

TRANSMISSION COOLER

An automatic transmission cooler shall be provided as an integral part located in the bottom tank of the radiator. It shall be designed to withstand 165 psi working pressure and an intermittent pressure of 250 psi. The cooler shall be of sufficient size to maintain the operating temperature within the recommended limits of the transmission manufacturer.

TRANSMISSION FLUID

The transmission shall be provided with heavy-duty transmission fluid meeting Allison specification TES-389.

FIVE SPEED PROGRAMMING

The transmission shall be programmed for five speeds.

First - 3.49

Second - 1.86

Third - 1.41

Alexis-2315

Fourth - 1.00
Fifth - 0.75
Reverse - 5.03

The transmission shall be able to shift from first through fifth gear without operator intervention. The chassis shall be geared for the top speed in 5th gear.

AUTOMATIC NEUTRAL

The transmission shall be provided with circuitry to provide automatic neutral. Setting the parking brake commands the transmission to neutral when the park brake is applied, regardless of drive range requested on the shift selector. Requires re-selecting drive range to shift out of neutral.

After the transmission has been activated with the automatic neutral feature the shift lever must be returned to neutral and back to drive for midship pump operations.

REMOTE FLUID LEVEL SENSING

The chassis shall be equipped with an electronic low fluid level indicator system for the engine oil, transmission oil, engine coolant and power steering fluid as part of the instrumentation package. This system eliminates the need for daily checking of fluid levels with manual dipsticks.

Coolant over temperature sensors are only capable of sensing excessive coolant temperature caused by clogged radiators, malfunctioning thermostats, failed water pumps or any other "circulation" problem. Upon loss of coolant, however, these temperature sensors must try to respond to hot air which, being a poor thermal conductor, results in signals that arrive only after the engine is severely damaged.

In a like manner, under leaking oil conditions low oil pressure signals are not obtained until the oil pump is starved for oil. Since the oil pump draws liquid from the very bottom of the crankcase pan, these signals arrive only after virtually all oil has been lost. Again, the damage has already occurred.

The liquid level sensor provides an early warning that fluid is being lost and allows corrective action to be taken before damage can occur. By using a sensor to turn on an indicator light, the low fluid level condition is communicated immediately to the operator.

ENGINE COOLANT

The coolant level sensor is located in the upper radiator reservoir. The corresponding LED indicator light is included in the display module.

ENGINE OIL

The engine oil sensor is in the engine oil sump. It monitors the oil level at approximately the 50% level. The corresponding LED indicator light is located to the right of the instrument panel on the doghouse in clear view of the driver.

POWER STEERING FLUID

The power steering fluid sensor is located in the power steering fluid reservoir at the same level as the "Add" indicator on the dip stick. The corresponding LED indicator light is located to the right of the instrument panel on the doghouse in clear view of the driver.

FUNCTION

The LED indicator lights will illuminate when the ignition is placed in the ON position as a test to insure that the warning circuits are working. They will go out when the starter button is pressed if normal fluid levels are detected. One or more of the lights staying on indicates a low fluid level in the corresponding system(s). Any time the engine is ON and a low fluid level is detected, the appropriate light will illuminate. The sensor output will reset when the ignition is turned off.

TRANSMISSION OIL

The transmission oil sensor is in the transmission oil sump. The fluid level indicator is integrated into the shift selector. Accessing the fluid level status is dependent upon the style of shift selector provided.

The transmission fluid level status is accessed through the "mode" function of the shift selector controls. First, park the vehicle on a level surface, shift to N (Neutral), and apply the parking brake. If equipped with a pushbutton shift selector, simultaneously press the Up and Down arrow buttons. If equipped with a lever shift selector, press the display mode button one time. A code will be displayed on the shift controls indicating that the oil level is HI, LO or OK. If the level is HI or LO, the display will also indicate the number of quarts of oil necessary to be added or removed to bring the oil level into the OK range. It may also display an error code that explains why fluid level information is not available. The fluid level check may be delayed until the following conditions are met:

- The fluid temperature is above 60°C (140°F) and below 104°C (220°F).
- The transmission is in N (Neutral).
- The engine is at idle
- The transmission output shaft is stopped.
- The vehicle has been stationary for approximately two minutes to allow the fluid to settle.

See the Care and Maintenance section of the transmission Owner's Manual for a more detailed description of the fluid check procedure along with a complete list of error codes.

DRIVELINES

Universal joints and driveshafts shall be SPICER 1760 series or equal. The driveshaft tube shall be a minimum of 4.09" diameter with a .180" tube wall thickness. The driveshaft slip joints shall be coated to reduce sliding friction and thrust under high torque loads. Permanent driveline installations shall be balanced to prevent vibration.

TEMPORARY DRIVELINE INSTALLATION

The drivelines and driveline center bearing supports shall be a temporary installation for completion by the apparatus manufacturer.

FUEL TANK

The fuel tank shall have a capacity of 50 gallons (US) and be D.O.T. certified. It shall be mounted with straps bolted to the bottom frame flange to allow for easy removal. The tank construction shall be of 12 gauge steel with

single fuel pickup and return tubes. The baffled tank shall be vented to prevent low vacuum and facilitate rapid filling.

The tank shall have a 2" NPT fill to the driver's side of the chassis.

The fuel tank sending unit is to be mounted to the driver's side of the fuel tank for easy replacement without removing body panels.

FUEL LINES

Polyamide fiber, nylon braided, reinforced tubing with push-on reusable fittings shall be provided for the chassis fuel lines.

FUEL/WATER SEPARATOR

The Cummins engine shall be equipped with an integrated fuel / water separator with a self venting bottom drain valve. This filter shall be able to remove up to 95% of dissolved water and up to 99% of free standing water.

ALTERNATOR

A LEECE-NEVILLE model LN4867J 270 Amp alternator shall be installed on the engine. This alternator is internally rectified and regulated.

FIRETRUCK CAB

The apparatus shall be designed to operate in emergency conditions. These conditions require the apparatus to maneuver into areas at a high rate of speed. To facilitate in these operations a cab-over-engine design is required in order to reduce the overall length of the apparatus thus increasing the maneuverability.

The cab design must be such to provide safe and efficient transport of emergency personnel. The cabin shall be designed with four (4) side doors of the largest size possible and with a grab handle and step arrangement to provide ease of entry and egress.

There shall be up to six (6) positions available for occupant transport with a minimum of four (4) forward facing seating positions in the cab. The number of seats and seating locations are described in detail later in this document.

The apparatus cab shall be of the latest in automotive design, styling and appearance.

CAB MATERIALS AND CONSTRUCTION

The extruded aluminum x/ cab shall have the following material gauges as a minimum:

- Cab floor - 3/16" (.190") aluminum
- Front skin - 3/16" (.190") aluminum

- Cab side panels - 3/16" (.190") aluminum
- Cab rear wall - 3/16" (.190") aluminum
- Cab driver's floor - 3/16" (.190") aluminum
- Cab officer's floor - 3/16" (.190") aluminum
- Cab crew area floor - 3/16" (.190") aluminum
- Cab roof - 3/16" (.190") aluminum
- Cab doors - 3/16" (.190") aluminum

Roof Rail Section Extending from the front to the rear of the cab above the doors the cab shall have an extruded aluminum section. This section shall be designed to interlock with the roof sheet and incorporate the door drip molding in one single piece.

Upper Transverse Member Amid ship in the cab there shall be a boxed beam header assembly located transverse in the cab from left to right.

Front Door B-Post This vertical box section of the cab located behind each of the front doors provides the slam post for the door latch assembly. This section also is a main member in the cab skeletal system. The B-Post ties into the Upper Transverse Member to provide torsional stiffness in the open space design of the cab.

Rear Door B-Post The box assembly design of the rear door B-post provides an anchor for the rear door latch assembly. This section is the main vertical support at the cab rear corner providing the anchor point for the rear wall structural lattice network.

Roof Panel Rails - The roof panel sub-assembly shall have extruded hat section supports bonded to the roof skin. These roof hat sections shall be joined to the Cab Roof Rail Section to complete the upper cab skeletal structure. These completed Roof Panel Rails shall provide a grid for maximum roof crush and deflection strength. The roof shall support a minimum weight of 250 lbs. / sq. ft. without permanent roof deformation.

Rear Wall Rails - The rear wall assembly shall have extruded hat section supports bonded to the wall skin. These sections shall be joined to the Roof Panel Rails and to the rear door slam post and floor provide a rear wall grid structure with maximum strength.

Cab Front Wall - The front wall of the cab shall be designed with a double wall construction to reduce the effects of exterior noise in the crew and operator compartment.

CAB DIMENSIONS

The cab shall have the following overall dimensional requirements:

- Overall Width - 100 inches
- Roof - 12" Raised
- Center of front axle to back of cab - 60 inches
- Center of front axle to front of cab - 74 inches
- Windshield area - 4,200 sq. in. minimum
- Front grille opening - 478 sq. in. minimum
- Combined side grille opening - 84 sq. in. each minimum
- Cab full tilt angle - 45 degrees minimum
- Cab full tilt height - 185 inches maximum

Cab interior dimensions shall be provided as a minimum in the following chart:

- Drivers side floor width 25-1/2 inches minimum
- Floor to the ceiling in the driver and officers area of the cab 59-1/2 inches minimum
- Floor to the top of the doghouse 28-1/2 inches maximum
- Officers side floor width 24-1/2 inches minimum
- The measurement across the floor from the rear wall to the first vertical portion of the engine enclosure 39 inches
- Floor to the ceiling in the rear of the cab 65-3/4 inches minimum

CAB DOORS

The cab entry and egress shall be designed for a firefighter in full turnout gear. Each door shall open a minimum of ninety degrees to afford the firefighter maximum space.

The doors shall be of a flush design each having exposed, one-piece, polished stainless steel hinges. The hinge shall be made of 12-gauge material with a minimum hinge pin diameter of 1/4 inch.

The door windows shall have interior and exterior glass weather seals to prevent the influx of exterior air.

The doors shall have exterior and interior paddle type latches for ease of opening with a gloved hand. The paddle latches are to have a rubber gasket, on the outside, separating the handle from the finished painted surface.

FRONT DOORS

The cab front doors shall be of the full-length design enclosing the entire step area of the cab. The door shall be a minimum of 38-1/2 inches wide and 74 inches tall. The front door windows shall have a minimum of 712 square inch area of viewing glass per door. There shall be a fixed piece of forward glass in each of the front doors.

REAR CAB DOORS

The rear cab doors shall be similar to the forward doors and shall be located directly behind the front wheel well area. These doors shall be 86 inches high x 34 inches wide. Each door shall have a roll down rear window with a minimum glass viewing area of 670 square inches.

INTERIOR DOOR LOCKS

All doors shall have door locks with interior controls and exterior keyed door locks. The installation shall be in conformance with FMVSS 206, with specific adherence to 49 CFR 571.206 Section 4.1.3 requiring that "Each door shall be equipped with a locking mechanism with an operating means in the interior of the vehicle". All doors shall be keyed alike. The doors shall be equipped with appropriate safety interlocks to prevent accidental locking of the doors when closed.

DASH TRIM

The drivers cab dash console shall be made of black ABS with an appearance of the latest in automotive design, styling. Accompanying the dash console in the forward section of the cab shall be an officers side flat dash for the mounting of a mobile data terminal.

CAB GLASS

AS-1 safety laminate glass shall be used in a two piece, wrap around design with a minimum 3760 square inches of windshield area for maximum visibility. The windshield shall have the style of a one-piece assembly with the practical installation of two pieces for lower replacement cost. The windshield shall be readily available from a nationally recognized automotive glass manufacturer that maintains local distribution outlets.

All glass shall be tinted.

All fixed glass shall be installed with a one-piece triple locked rubber lacing material. Due to long term appearance two-piece chrome trim lock lacing is not desired.

SUNVISORS

The driver and officer side of the cab shall be equipped with a sun visor. The vinyl covered visors shall be a minimum of 17-1/2" by 9".

DRIVER SIDE ELECTRICAL CABINET

Beneath the drivers seat there shall be an electrical cabinet designed to house the main battery electrical disconnect and facilitate the installation of an onboard battery charger or battery conditioner. A bolt on limited access; aluminum diamond plate hatch shall be installed on the front side of the seat box. The access hatch shall have a louvered section to provide air circulation to the cabinet. This cabinet shall not be used for casual storage.

WINDSHIELD WIPERS

Two speed electric pantograph wipers shall be installed. These wipers shall have minimum 24" blades and have 28 1/2" wet arm electric pump washers. A 70 oz. Minimum windshield washer reservoir shall be furnished.

FASTENERS

All cab exterior fasteners shall be stainless steel type fastened to the cab with nutserts.

BATTERY ACCESS

The rear cab steps shall have a removable kick panel, providing access to the batteries for routine maintenance and inspection.

CAB CORROSION TREATMENT

The cab shall have a corrosion preventative material conforming to Mil Spec C-16173-C, Grade 1, applied during and after construction. A 10-year warranty against perforation due to rust or corrosion shall be furnished for the cab.

TRANSMISSION RANGE SELECTOR

The transmission shall be controlled by an electro-mechanical lever type shift control. It shall be internally illuminated for night operation and have an internal lock (hold override button) to securely hold the shifter in the

position selected.

TRANSMISSION OIL LEVEL SENSOR

The transmission shall be equipped with the oil level sensor (OLS). This sensor shall allow the operator to obtain an indication of the fluid level from the shift selector. The sensor display shall provide the following checks, correct fluid level, low fluid level and high fluid level.

EMI/RFI PROTECTION

The apparatus shall incorporate the latest designs in the electrical system with state of the art components to insure that radiated and conducted electromagnetic interference (EMI) and radio frequency interference (RFI) emissions are suppressed at the source.

The apparatus proposed shall have the ability to operate in the environment typically found in fire ground operations with no adverse effects from EMI/RFI.

EMI/RFI susceptibility is controlled by utilizing components that are fully protected and wiring that utilizes shielding and loop back grounds where required. The apparatus shall be bonded through wire braided ground straps. Relays and solenoids that are suspect to generating spurious electromagnetic radiation are diode protected to prevent transient voltage spikes.

In order to fully prevent the radio frequency interference the purchaser shall be requested to provide a listing of the type, power output, and frequencies of all radio and bio medical equipment that is proposed to be used on the apparatus.

BATTERY BOX TRAY - STAINLESS STEEL

The battery box trays shall be stainless steel to reduce the corrosive potential of the tray. The battery hold down and brackets and hardware shall also be made of stainless steel.

BATTERY BANK

A single battery system shall be provided, utilizing four (4) high cycle type Group 31 batteries.

This system shall be capable of engine start after sustaining a continuous 150 amp load for 10 minutes with the engine off (NFPA-1901).

A battery disconnect switch (Rated at not less than 450 amps continuous) shall be used to activate the system and provide power to the power panel. A green pilot light shall illuminate to indicate that the 1 battery bank is activated.

BATTERY CABLES

All battery wiring shall be "GXL" battery cable capable of handling 125% of the actual load. It shall be run through a heat resistant flexible nylon "HTZL" loom rated at a minimum of 300 degrees Fahrenheit. All cable connections shall be machine crimped and soldered.

STARTING CIRCUIT

One (1) engine start button is to be located on the lower right dash panel. It shall be wired to heavy duty solenoid rated at not less than 1100 amps. The battery indicator light is to be located directly above the start button to indicate that the battery bank is on.

ON-BOARD ELECTRICAL AIR COMPRESSOR PUMP PLUS CHARGER

A KUSSMAUL AUTO AIR model 091-9-1200 air compressor with a 40 amp automatic battery charger shall be supplied on the chassis. A pressure switch senses when the system pressure drops and starts the compressor which then runs until pressure is restored. All ball bearing construction, lubricated for life, assures reliable operation and requires no servicing. Compressor Output: 0.30 CFM@80 PSI; 0.35 CFM@60 PSI. Pressure Switch: Adjustable Set Point-Factory set to 75 PSI Cut-in, 95 PSI Cut-out.

The Pump Plus 1200 charger senses the batteries in the vehicle and recharges exactly as much as required. When the batteries are fully charged, all charging stops. The state of charge of the batteries is indicated on a remotely located bar graph display whenever power is applied to the vehicle.

A selector switch is provided on the charger to operate the compressor either as a D.C. compressor or as an A.C. compressor. In either switch position the compressor operates from the vehicle's battery. When "D.C." is selected, the compressor operates whenever the pressure switch senses low system pressure. This is useful when parking the vehicle away from the 120 volt input power. For those operators who wish to limit compressor operation to the times when the shoreline is connected to the vehicle, the Selector Switch should be placed in the "A.C." position. This will operate the compressor when the A.C. power is available, but shuts off the compressor when the shoreline is removed. In either switch position the compressor is operated by the vehicle's battery.

The compressor shall be located in the officer's side front step well with a bolt on style access panel. As installed in the chassis the compressor power selector switch will be placed in the A.C. position.

The remote charge indicator shall be located on the driver's seat box adjacent to the master battery switch.

SHORELINE AUTO-EJECT

A KUSSMAUL Super Auto Eject, model 091-55-20-120, with weatherproof cover shall be provided.

The Super Auto Eject is to be completely sealed to prevent internal contamination of the working components.

The internal switch arrangement of the Super Auto Eject shall be designed to close and open the 120-volt AC circuit after the mating connector is inserted and before the connector is removed. This design shall prevent arcing at the connector contacts to provide long life.

The electrical connection shall be provided as a 120-volt AC - 20 amp type using a NEMA 5-20P connector.

The Auto-Eject cover shall be a Kussmaul 091-55RD, red in color.

The Auto Eject assembly shall be mounted on the exterior of the cab behind the driver's door.

BATTERY JUMPER STUDS

Battery jumper studs shall be provided on the chassis. The jumper studs shall be mounted underneath the cab, on the rear of the driver's side battery box. The studs shall be connected to the chassis batteries with 1/0 color coded cables, red for the positive cable and black for the negative cable. The studs shall be protected with color coded plastic covers when not being used.

ENGINE DOGHOUSE

The engine doghouse inside the cab will be padded with a layer of sound and heat absorbing foam and covered with heavy duty vinyl trim upholstery to match or accent the interior of the cab.

The underside of the engine enclosure shall be covered with a sandwiched material for interior cab noise and heat rejection. This sandwiched acoustical material shall have one layer of 1/8" foam, a 3/16" single barrier septum and a 7/8" layer of foam to provide an overall thickness of 1-3/16". The sandwich material shall be chemically bonded to prevent layer separation. A finished surface treatment of metalized film shall be provided on the engine side of the barrier. The acoustical barrier shall be held in place with mechanical fasteners in addition to adhesive.

The insulation for protection from heat and sound shall keep the dBa level within the limits stated in the current edition of NFPA 1901.

CAB DOORS - INTERIOR TRIM

To provided durability the interior of the cab doors shall be finished with full length aluminum panel that is finished with Zolatone high abuse paint.

INTERIOR CEILING PADDING AND TRIM

The cab front interior ceiling shall have a one-piece, removable, vinyl headliner to cover all wiring and tubing used for lights and antenna leads.

REAR WALL COVERING

The rear interior wall of the cab shall have a two-piece, removable, wall covering to finish the interior trim, cover all wiring and tubing used for lights and antenna leads.

FLOOR COVERING

The front and rear floor areas of the cab shall be covered with "HUSHCLOTH" sound barrier floor mats. This floor mat shall be a three ply material with a 3/16" thick open cell isolation barrier of Polyurethane, a 3/32" thick closed cell Nitrile mid barrier for section reinforcement, and a 1/16" thick embedded pebbled grain wear surface.

REAR FACING SEAT BOX COVERING

The rear facing seat box area of the cab shall be covered with "HUSHCLOTH" sound barrier floor mat. This floor mat shall be a three ply material with a 3/16" thick open cell isolation barrier of Polyurethane, a 3/32" thick closed cell Nitrile mid barrier for section reinforcement, and a 1/16" thick embedded pebbled grain wear surface. The seat box covering shall blend with the cab interior paint color.

REFLECTIVE MATERIAL - INTERIOR CAB DOOR

The cab and crew compartment doors shall have a minimum of 96 square inches of white reflective material affixed to the inside of each door.

INTERIOR CAB STEP TRIM

The cab steps shall be completely enclosed behind each door. The top surface of the steps shall be covered with non-skid aluminum treadplate trim.

RADIO COMPARTMENT

Beneath the officer's seat there shall be a radio compartment with an interior dimensions of 19-1/2" wide x 17" long x 7" high.

CAB STEP DIMENSIONS

The front cab steps shall have the following overall dimensional requirements:

- Driver's lower step size 10-1/4 inches deep minimum
- Driver's lower step size 29-1/2 inches front to back
- Officer's lower step size 10-1/4 inches deep minimum
- Officer's lower step size 29-1/2 inches front to back

INTERMEDIATE CAB STEP

The cab shall have a full width intermediate "LaserGrip" anti slip inside step. The intermediate step shall be approximately 9 inches from the top of the lower step to the top of the intermediate step.

INTERIOR CAB STEP TRIM

The cab steps shall be completely enclosed behind each door. No portion of the cab entrance step shall be exposed when the door is in the closed position. The lower step shall be sealed from the underside of the cab to eliminate road splash from entering the step area while the vehicle is driving. The horizontal step surfaces shall be covered with bright aluminum tread plate meeting the requirements of NFPA-1901.

The vertical toe kick surface area of the cab step wells shall be covered with aluminum tread plate.

COMPARTMENT OPEN LIGHT

A Red Open Compartment Flashing Light, Whelen OS Series LED shall be mounted on the driver's side face of the overhead panel. A chrome flange is to be supplied with the light.

This light is wired with a flasher to the power panel for completion to circuit on the body.

The light circuit shall be wired so that the light circuit is deactivated when the parking brakes of the apparatus are applied.

A label shall be applied adjacent to the light 'DOOR OPEN'.

Interior Lighting Group - 1871W - 1871SFO

LED Strip Light Interior Light Packages

CAB FLOOR STEP LIGHTING

The floor of the cab shall be trimmed with a ribbed aluminum extrusion. The extrusion shall protrude as a approximately 3/4" over the floor area to provide a mounting channel and guard for an LED integrated light. The LED lighting shall illuminate the step area of the cab and all step lights shall be illuminated when any door is opened and the battery selector switch is in the on position.

DRIVER & OFFICER AREA WHITE LED CAB LIGHTING

There shall be a white LED strip lighting mounted above the full length of each front door in the cab. The strip light shall be mounted in an aluminum extrusion and shall face the center of the cab.

The lighting shall be operated opening a cab door.

CREW AREA WHITE LED CAB LIGHTING

There shall be a white LED strip light mounted in the cab. The LED strip light shall be mounted on the bolster in the center of the cab and shall run the full width of the cab. The strip light shall be mounted in an aluminum extrusion and shall face the rear of the cab.

The lighting shall be operated opening a cab door.

CREW AREA WHITE LED CAB LIGHTING

There shall be a white LED strip light mounted in the cab. The LED strip light shall be mounted at the ceiling on the rear wall and shall run the full width of the cab. The strip light shall be mounted in an aluminum extrusion and shall face the rear of the cab.

The lighting shall be operated opening a cab door.

CREW AREA WHITE LED CAB LIGHTING

There shall be a white LED strip lighting mounted above the full length of each cab crew door in the cab. The strip light shall be mounted in an aluminum extrusion and shall face the center of the cab.

The lighting shall be operated opening a cab door.

CREW AREA RED LED CAB LIGHTING

There shall be a red LED strip light mounted in the cab. The LED strip light shall be mounted on the bolster in the center of the cab and shall run the full width of the cab. The strip light shall be mounted in an aluminum extrusion and shall face the rear of the cab.

The lighting shall be operated by a toggle switch mounted on the forward post of the crew area door on each side of the cab.

CREW AREA RED LED CAB LIGHTING

There shall be a red LED strip light mounted in the cab. The LED strip light shall be mounted at the ceiling on the rear wall and shall run the full width of the cab. The strip light shall be mounted in an aluminum extrusion and shall face the rear of the cab.

The lighting shall be operated by a toggle switch mounted on the forward post of the crew area door on each side of the cab.

HEATER / DEFROSTER

A 57,600 BTU heater with a three speed fan shall be mounted in the front of the cab, centered over the windshield. This heater shall have six (6) adjustable vents to assure windshield defogging.

DEFROSTER FANS

Two (2) 6" windshield defroster fans shall be mounted on the overhead console, one each side of the center of the cab.

45,000 BTU AIR CONDITIONING

A climate control system shall be furnished in the cab. The system shall consist of a 46,000 BTU air conditioning evaporator centrally located on the forward slope of the raised roof.

The system is to have a 13.1 cu. in. minimum compressor mounted on the engine to provide the compressed refrigerant to the system. The compressor is to be plumbed to a heavy duty truck, triple fan air conditioning condenser mounted on the cab roof. The condensing unit shall have an aerodynamic shroud that is painted to match the color of the cab roof. There shall be an extended life filter receiver/dryer with a pressure relief valve installed to protect the system from contaminants, moisture, and high pressure. It is to have a sight glass for visual inspection and ease of service.

The evaporator shall have an externally equalized expansion valve and be thermostatically protected to prevent freeze up. Dual high performance 3-speed blowers shall provide a minimum of 700 CFM air flow. Each blower is to be controlled separately. Eight (8) downward facing adjustable diffusers with shutoff capability shall be utilized to direct the air flow through the cab.

The air conditioning controls, on/off switch, thermostat control, and blower switches shall be located on the climate control display module within reach of the driver.

The climate control system shall utilize both automatic and manual control methods.

The climate control display's system standby screen shall maintain all of the climate control functions OFF.

The climate control display's automatic operation screen shall allow the user to select a desired temperature and the climate control system shall automatically choose the temperature mode (cool or heat) and the fan speed (low, medium or high) to maintain the desired temperature.

The climate control display's manual operation screen shall allow the user to set the temperature mode (cool or heat) and the fan speed (low, medium or high) as desired.

CAB INSULATION

Foam rubber type insulation shall be installed in the rear wall and the cab ceiling to provide a better sound and heat barrier. The insulation shall be a minimum of 1" thick. The material shall be compliant with FMVSS-302.

FLOOR HEAT - DRIVER & OFFICER

There shall be two (2) quartz heaters provided for floor in the front of the cab, one (1) for the driver and one (1) for the officer's floor area. The heater shall contain polymer composite heating elements encapsulated in a vacuum sealed quartz tube specifically designed for direct current. The polymer elements shall feature a life expectancy of 10,000 hours and shall be designed to be the ultimate in durability where vibration, moisture, and durability may be a factor. The polymer element shall be vacuum sealed in a "Ruby" Quartz tube to protect it from any moisture or harsh conditions. Injection molded high temp silicone tube boots shall be designed to absorb vibration and will minimize any shock to the elements. A single heater control switch shall be provided to control both heaters with two heat settings.

REAR SUPPLEMENTAL CAB HEATER

An auxiliary heater shall be installed on the rear wall of a tilt cab, centered, at the floor line, If there are forward facing seats the heater shall be located under the seats. This heater shall be capable of 325 SCFM air flow and be rated for 25,000 BTU/HR with a delta T of 180 degrees F.

DRIVER INSTRUMENTATION AND CONTROLS

The gauges shall have red LED back lighting for enhanced visibility. Upon on initial ignition sequence a lamp check function shall illuminate the warning light telltales, the self diagnostic message center shall sequence the warning light telltales if data link communications are lost. The instrument panel shall include the following gauges and indicators.

- Electronic speedometer with LCD odometer

- Tri cluster gauge that includes:

 - Electronic tachometer

 - Engine coolant temperature gauge, with warning light and buzzer

 - Engine oil pressure gauge, with warning light and buzzer

- Transmission fluid temperature gauge, with warning light and buzzer

- Two air pressure gauges, with warning light and buzzer

- Voltmeter, with low voltage warning light and buzzer

- Fuel level gauge

- High beam indicator light

- Parking brake set light

- Turn signal indicator lights

The lighting control panel is to be located to the left side of the instrument panel. The lighting control panel shall include the following:

- Headlight control switch

- Dash rheostat for instrumentation lighting control

- Wiper and washer control switches

The engine control panel is to be located beneath the instrument panel on the driver's right hand side. The engine control panel shall include the following:

Keyless ignition switch with a green pilot light

The apparatus control panel is located beneath the instrument panel on the driver's left hand side. The apparatus control panel is designed for the location of pump shift controls.

AUDIBLE TURN SIGNAL REMINDER

There shall be an audible alarm that shall sound when the turn signal remains flashing for a distance greater than one mile. The reminder shall not sound when the hazard lights are operating.

AUDIBLE LIGHTS ON REMINDER

There shall be an audible alarm that shall sound when the headlight switch is left in the on position and the ignition is off. The alarm shall self cancel after 2 minutes of operation.

AUDIBLE PARKING BRAKE REMINDER

There shall be an audible alarm that shall sound when the parking brakes are NOT set and the ignition is turned off. This alarm shall self cancel after 2 minutes.

The Parking Brake reminder shall sound an audible alarm when the parking brakes are set and an indicated speed of over two miles per hour occurs.

DUAL TRIP ODMETERS

There shall be two (2) trip odometers in the driver's information center. Each shall be capable of independent operation and reset. They shall be labeled Trip1 and Trip2 when the trip mileage is shown in the LCD panel.

SPEEDOMETER ACTIVATED IN PUMP MODE

The speedometer and odometer shall be activated while in pumping mode.

LOW FUEL LIGHT

A "Low Fuel" warning light and alarm shall be installed in the dash message center. This light shall illuminate when the apparatus fuel level reaches 25% of the fuel remaining.

TRANSMISSION OVERHEAT WARNING LIGHT

A transmission oil temperature light with alarm shall be provided on the dash message center.

LOW VOLTAGE WARNING

A low voltage indicator light shall be installed on the dash message center. An alarm and the dash indicator light shall activate when the system voltage drops below 11.8 volts.

AIR CLEANER RESTRICTION INDICATOR

An air cleaner restriction indicator shall be installed in the driver's message center. The indicator shall provide visual warning when a high air restriction condition exists for a minimum of 4 seconds.

LOW COOLANT WARNING

Low coolant warning shall be accomplished through the engine electronics to provide driver warning via the engine stop warning light.

INTERMITTENT WIPER CONTROL

A rotary combination intermittent electric wiper / washer switch shall be provided on the left hand side of the driver's dash.

CONTROL CENTER

Mounted on the doghouse there shall be a driver / officer control center. This area shall include various controls and functions that must be available to the driver and officer.

The apparatus warning light switch panel shall be mounted on the control center immediately to right of the driver. The panel will have a black anti-glare surface, and within easy reach of the driver. The panel shall include one (1) lighted master control switch to allow for preselection of the other switches and thirteen (13) lighted individual lighting control and chassis option switches.

Each switch shall have back-lit legends with a 100,000 hour lamp for illumination.

The master lighting control switch shall be wired to three (3) 30 amp circuit breakers and three (3) 40 amp relays. Three (3) 10 gauge wires are powered by this circuit and run to the roof for light bar power. The remaining switches shall be wired to 20 amp circuit breakers and relays.

PARKING BRAKE CONTROL VALVE

The parking brake control valve shall be located in the driver's dash engine control panel.

CUP HOLDERS

There shall be two (2) recess mounted cup holders mounted on top of the doghouse console.

CHASSIS ELECTRICAL SYSTEM

The apparatus "Electrical Distribution System" (EDS) shall be mounted inside the cab to prevent moisture from entering the area. It shall be mounted under the dash on the officer's side behind a diamond plate cover.

The EDS shall be fed by one power stud:

One (1) battery positive

The battery positive stud is to be controlled by the master disconnect switch mounted on the lower right dash panel. A green light shall indicate when the ignition circuit(s) are energized.

EDS MODULE

The EDS system shall be designed with locally available **plug-in** circuit breakers and **plug-in** relays. Each component position shall be labeled to indicate its function. All electrical connections shall be insulated and secured behind the panel face to eliminate the chance of accidental electrical shorts while performing electrical system service.

The EDS shall control a minimum of thirteen (13) low voltage, analog switched, high amperage electrical loads.

Provision for a minimum of thirty-one (31) automatic reset circuit breakers is required to protect the vital circuits of the apparatus.

The EDS system shall be removable with only four (4) fasteners for major electrical service or modifications.

The EDS panel shall have one (1) lamp for illumination of the panel during service.

CHASSIS COLOR CODED WIRING

All chassis wiring shall be type "GXL" in accordance with S.A.E. J1128 and NFPA-1901. ALL wiring shall be **COLOR CODED** and continuously marked with the circuit number and function.

All wiring to be covered in nylon heat resistant "HTZL" loom rated at a minimum of 300 degrees F exceeding the heat requirements of NFPA-1901.

A battery "loop back" ground circuit shall be supplied for the EDS system to reduce the possible effects of Electromagnetic and Radio Frequency Interference.

The chassis cab, engine and transmission shall be electrically bonded to the chassis frame rails with braided ground straps.

ELECTRICAL SYSTEM CONNECTORS

All multiple conductor electrical connections shall be made with Packard electrical connectors. The Packard connectors shall become mechanically locked when mated.

All single wire terminations requiring special connectors with a ring or spade terminal shall be crimped, and wrapped with heat shrink tubing.

12VDC POWER POINT

A 12 volt, socket (cigarette lighter) type, receptacle shall be provided with a protective hinged cover.

The power point shall be wired to switched battery power with the appropriate wire size and fuse.

The power point socket shall be provided within reach of the officer.

12VDC POWER POINT

A 12 volt, socket (cigarette lighter) type, receptacle shall be provided with a protective hinged cover.

The power point shall be wired to switched battery power with the appropriate wire size and fuse.

The power point socket shall be provided within reach of the driver.

12VDC POWER CIRCUIT

A circuit protected 30 amp battery "hot" circuit, a circuit protected 30 amp battery switched circuit, and a ground circuit with the proper wire size to handle the current shall be provided. These circuits are provided for two-way radio and/or accessory wiring.

The radio / accessory power circuit shall terminate in the power panel area of the cab.

RADIO ANTENNA MOUNT WIRING

One (1) NMO mount shall be roof mounted, on the officer's side of the cab.

The antenna mount shall be located 34 inches from the front face of the cab and 18 inches from the cab side.

The unterminated coax is to be routed in the cab to the radio power circuit termination or officer's seat box if no radio power circuit is requested.

The antenna wiring shall terminate in the center of the cab on top of the engine doghouse.

PUBLIC BROADCAST RADIO

The cab shall be equipped with an AM/FM CD Stereo Radio with four ceiling mount recessed speakers. The radio shall also include a seven channel weather band.

ROAD SAFETY KIT

One (1) 2-1/2# ABC DOT Approved fire extinguisher shall be provided. The fire extinguisher shall be shipped loose with the chassis.

One (1) set of DOT approved hazard triangles shall be supplied with the chassis. They shall be stored in a plastic case and shipped loose with the chassis.

CAB CRASHWORTHINESS TEST

Dynamic tests shall be performed to evaluate the crashworthiness of the proposed vehicle cab configuration to the requirements of NFPA 1901-09 section 14.3.2.

Cab roof strength shall be tested utilizing the dynamic preload criteria from SAE J24221 paragraph 5 specifications and procedures.

Front impact strength integrity shall be tested utilizing SAE J24202 with ECE R293 Annex 3 paragraph 4 equivalent energy.

Quasi-static roof strength shall be based on SAE J2422 paragraph 6 and ECE R293, paragraph 5 specifications and procedures.

A letter of certification shall be provided upon request by the department.

EXTERIOR GRAB HANDLES

The cab shall have a bright anodized extruded aluminum 24" grab handles at each door position. The aluminum shall be bright anodized for long service. Molded rubber gaskets shall be installed under the grab handles to protect the painted surface of the cab.

LIGHTING, CAB HANDRAIL

The cab handrails shall contain integrated LED lighting. The lighting shall be integrated into the grab bar, directed toward the cab. The assembly shall illuminate the same time as the ground lights.

The LED handrail lighting shall be white in color.

CAB GRILLE

All cab exterior grilles shall be bright finished stainless steel. The front grille shall have a radiator rock guard to assist in preventing damage to the radiator core.

The cab shall have one (1) engine "hot" air exhaust and one (1) engine air cleaner intake, on each side of the cab. These openings shall be covered with a honey comb wire screen and shall have a bright polished stainless steel outer grille.

CAB MUDFLAPS

Mud flaps shall be installed behind the front tires. These mud flaps shall be a minimum of 22" wide to protect the underneath of the cab and body.

CAB GROUND LIGHTING - LED

One (1) LED, round 4" LED light shall be mounted beneath each door. These lights shall be designed to provide illumination on areas under the driver and crew riding area exits. All cab ground lights shall be switchable and shall automatically activate when any cab exit door is opened.

MIRRORS

MOTO-MIRROR 16 1/2" X 7" stainless steel heated, remote control mirror heads shall be mounted on spring loaded retractable mirror arms. Includes a 5-1/2" x 8.5" convex mirror head.

CAB SIDE WINDOWS

Two AS-2 tempered glass, fixed side windows, 26-1/2" high x 16" wide shall be furnished, one on each side behind the forward doors. All glass shall be tinted. These windows shall be installed with a one-piece triple locked rubber lacing material.

REAR WINDOW SAFETY BARS

There shall be a one inch stainless steel grab bar installed on each rear door. This bar is to be installed on the rear door frame even with the window in the down position to prevent firefighters from using the glass in the door for a handle.

UNDER CAB ENGINE MAINTENANCE LIGHTS

Two (2) engine maintenance lights shall be supplied beneath the cab. These lights shall illuminate automatically when the cab is tilted to the full tilt position.

STAINLESS CAB FENDERETTES

To reduce road splash on the cab sides, polished stainless steel fenderettes shall be installed around each the wheel opening.

EXTERIOR REAR WALL DIAMOND PLATE OVERLAY

The cab exterior rear wall shall be covered with a single sheet of bright aluminum tread plate to protect the back of the cab from scratches.

CAB TILT SYSTEM

The cab shall tilt a minimum of 45 degrees for ease of serving. Tilting shall be accomplished by means of a tilt pump connected to two (2) heavy duty lift cylinders. It shall be equipped with a positive locking mechanism (service lock) to hold the cab in the full tilt position. Release of the service lock shall be by means of a pull type cable assembly. The cylinders shall have a velocity fuse at the base to prevent the cab from falling in the event of a hydraulic hose failure. The cab shall be capable of tilting 90 degrees for major engine service, if necessary. The 90 degree cab tilt shall be accomplished by removing the cab cylinder pins, removing one bolt in the steering shaft, and removing the front bumper and treadplate.

The cab shall have a three (3) point cab locking system. To prevent undue stresses in the cab, the cab mounting shall incorporate a five (5) point load mounting system.

The front cab pivot/lock assemblies shall utilize four (4) radially loaded, bonded rubber, axial mounts. These mounts shall have a maximum radial load rating of 925 pounds each and a torsional rating of 25 lbs-in/deg. Two one (1) inch diameter cab pivot pins shall be installed at the front of the cab.

The rear cab lock shall be center point mounted to prevent normal twist of the chassis from affecting the cab mounting, cab structure and windshield areas of the cab. This rear cab lock shall be mounted on a chassis crossmember to provide a stable platform for the locking system. The cab lock shall be mounted to a baseplate that is fastened to rubber isolators to reduce road noise and provide additional movement of the cab lock. This locking system shall automatically open prior to the cab tilting and automatically relatch when the cab is lowered completely into the travel position.

Two (2) outboard frame mounted urethane "V" blocks shall be provided at the rear of the cab. These dual purpose mounts shall align the cab upon lowering as well as provide non-latching support for the cab in the down position. With this system, extreme chassis twist shall allow the cab to move independently of the rear cab supports, reducing the structural stress damage often caused by outboard dual cab locking systems.

An electric-over-hydraulic cab tilt pump shall be supplied. This pump shall have a remote control for cab tilting

operation. The control shall be "safety-yellow" in color.

CAB TILT INTERLOCK

The cab lift system shall have a cab tilt interlock. The cab tilt shall not be able to be activated unless the master battery switch is in the on position with the parking brake set.

INTERIOR FINISH

The entire interior of the cab shall be painted with spatter paint, gray in color. Gray spatter paint is selected for ease of repairs when the interior is scratched.

The cab metal finish shall be covered with one coat of base self-etching primer to fill the small surface imperfections.

Then the interior of the cab is to be blocked and a coat of sealer-primer is to be sprayed to the interior finish.

Next a sealer primer is applied and shall be sanded to a smooth finish ready for final color coat application.

Two (2) coats of finished paint are to be applied to a final thickness of 4 mills.

The following interior components shall be finished in black:

- Overhead console
- Sun visors

The interior headliner of the cab shall be gray in color.

The interior rear wall covering of the cab shall be gray in color.

The interior flooring material of the cab shall be gray in color.

The interior door panel material of the cab shall be gray in color.

The doghouse covering material in the cab shall be gray in color.

The dash housing, doghouse console; when so equipped; and the officer's glove box or console shall be black in color.

CAB EXTERIOR FINISH

The exterior doors and all fixed cab glass are to be removed from the cab prior to the paint and body process beginning.

The final finish of the cab shall be to fire apparatus standards; exhibiting excellent gloss durability and color retention properties.

PREPARATION

The removal of all contaminants and oxidation is essential to the final effect of a finish system, the cab shall be precleaned with a Wax and Grease Remover and prior to evaporation, towel dried.

To remove all oxidation and foreign materials, the cab shall be sanded with a 180 grit abrasive using an orbital type disc sander.

All weld marks and other major surface imperfections shall be filled with a polyester type body filler, prior to body filler application special attention shall be given to the areas requiring filler again sanding and cleaning.

The body fillers shall be thoroughly mixed in accordance with the manufacturer's directions.

After the final coat of filler is sanded, spray polyester shall be applied in sufficient amounts as to provide a final base and sanded with abrasive paper.

PRECLEAN

Within 45 minutes of pretreat the cab must be again washed with a Wax and Grease Remover using a "Scotch brite pad". Towel dry prior to evaporation.

Special precaution shall be taken NOT to saturate any polyester body fillers with the cleaning solvents.

PRETREAT AND PRIMERS

The pretreat and primer applications shall be made in two independent steps. A combined pre-treat/primer one product application shall not be allowed as a substitute.

The prepared substrate shall be pretreated with an acid curing 2-component Transparent Primer. This pretreat shall be designed to provide corrosion protection and to create an adhesive bond between the substrate and the surface applications.

It is critical that the body fillers not receive a saturation of solvents associated with the pretreat application. Only the pretreat over spray resulting from product application to the adjacent metal areas should be allowed to come in contact with the body fillers.

All polyester body fillers are porous, and shall absorb liquids. Solvents when absorbed not only soften but shall create swelling of the polyester filler. After sanding and later shrink the fillers shall create blemishes in the painted surfaces.

Prior to complete primer application, each area with applied body fillers be precoated with a 2-dry applications of primer (sander surfacer) of which shall be allowed to "Touch Dry" between coats. This procedure shall isolate the filled areas and protect them from subsequent product applications.

The primer (sander surfacer) shall be a poly-acrylic resin, zinc and chromate free surfacer that is designed to create a superb surface smoothness, increase the depth of color, and insure top coat gloss.

The cab after pretreat and precoat shall be primed with a 3 to 4 medium applications of a Hi-Build Tintable Surfacers.

To create a finish base that meets the rigid requirements of the fire and emergency service; the primed surface shall be dry sanded smooth thus removing all texture and surface imperfections with a 320 grit (minimum) sanding abrasive.

FINISH AND COLOR COATS

The color coat application shall consist of two to three applications of acrylic urethane color coat. After the color coat has been applied, the cabs shall be sprayed with 1.5 to 2.0 mills of clear coat finish. The clear coat finish is then sanded and buffed to remove any imperfections that can occur during the application of the color coat.

The final finish shall be free of dirt and sags and shall meet a minimum grade of 7 when compared to the "ACT" general orange peel standards by "ACT" Laboratories, Inc. Of Hillsdale, MI.

The final sanding and buffing of the clear coat shall result in a flat / glass like finish. The clear coat shall also provide a UV barrier to prevent fading and chalking.

PPG brand urethane materials will be used for the cab exterior paint.

CAB PAINT WARRANTY WARRANTY

The chassis manufacturer shall provide a limited parts and labor warranty to the original purchaser of the custom built cab & chassis for a period of sixty (60) months. The warranty period shall commence on the date the vehicle is delivered to the end user. The warranty shall include conditional items listed in the detailed warranty document which shall be provided upon request.

DRIVER'S SEATING POSITION

The seat shall be H.O. Bostrom, air ride suspension, high back seat with fore and aft slide adjustment. The seat shall have adjustments for height and ride.

A red 3-point, shoulder harness type seat belt shall be supplied for the seat.

OFFICER'S SEATING POSITION

The seat shall be H.O. Bostrom, Tanker Series Self-Contained Breathing Apparatus (SCBA) type seat with a fixed bottom cushion and a pivoting head rest. The seat shall contain a SCBA filler pad for when the bottle is not in use.

A red 3-point, shoulder harness type seat belt shall be supplied for the seat.

SCBA SEAT BRACKET

There shall be a H.O. Bostrom SecureAll™ self-contained breathing apparatus bracket mounted into the seat cavity.

CREW AREA - REAR FACING LEFT OUTBOARD SEAT POSITION

The seat shall be H.O. Bostrom, Tanker Series Self-Contained Breathing Apparatus (SCBA) type seat with a fixed bottom cushion and a pivoting head rest.

A red lap type, metal to metal quick release seat belt, with automatic seat belt retractor shall be provided for the seat.

SCBA SEAT BRACKET

There shall be a H.O. Bostrom SecureAll™ self-contained breathing apparatus bracket mounted into the seat cavity.

CREW AREA - REAR FACING RIGHT OUTBOARD SEAT POSITION

The seat shall be H.O. Bostrom, Tanker Series Self-Contained Breathing Apparatus (SCBA) type seat with a fixed bottom cushion and a pivoting head rest.

A red lap type, metal to metal quick release seat belt, with automatic seat belt retractor shall be provided for the seat.

SCBA SEAT BRACKET

There shall be a H.O. Bostrom SecureAll™ self-contained breathing apparatus bracket mounted into the seat cavity.

CREW AREA - FORWARD FACING LEFT INBOARD SEAT POSITION

The seat shall be H.O. Bostrom Tanker Series Self-Contained Breathing Apparatus (SCBA) type seat with a flip bottom cushion and a pivoting head rest.

A red 3-point, shoulder harness type seat belt shall be supplied for the seat.

SCBA SEAT BRACKET

There shall be a H.O. Bostrom SecureAll™ self-contained breathing apparatus bracket mounted into the seat cavity.

CREW AREA - FORWARD FACING RIGHT INBOARD SEAT POSITION

The seat shall be H.O. Bostrom Tanker Series Self-Contained Breathing Apparatus (SCBA) type seat with a flip bottom cushion and a pivoting head rest.

A red 3-point, shoulder harness type seat belt shall be supplied for the seat.

SCBA SEAT BRACKET

There shall be a H.O. Bostrom SecureAll™ self-contained breathing apparatus bracket mounted into the seat cavity.

FORWARD FACING SEAT RISER

The center forward facing seat(s) shall be installed on a powder coated aluminum riser. The front of the seat riser will be open without a restraint system to provide a location for storage of small lightweight gear.

The seats shall be gray in color.

VINYL MATERIAL

The chassis seats shall have vinyl material in the following applicable areas:

- Seat Base Top
- Seat Base Sides
- Seat Back Support Face
- Seat Back Support Sides

- Seat Headrests

Standard Seat Cushions

SEAT BELT WARNING LABELS

The cab shall be equipped with two (2) seat belt warning labels. These labels are to be in full view of the occupants in the seated position.

VEHICLE DATA RECORDER

Apparatus shall be equipped with a Class1 "Vehicle Data Recorder and Seat Belt Warning System" (VDR/SBW) that is connected to the power train CAN (Controller Area Network) bus consisting of transmission (TCM), engine control (ECM) and antilock brake (ABS) modules mounted on the apparatus. The VDR/SBW will function per NFPA 1901-2009 sections 4.11 (Vehicle Data Recorder) utilizing the power train's J1939 data and 14.1.3.10 (Seat Belt Warning) using the Class1 "Seat Belt Input Module" for seat occupied and belt status information.

The VDR data shall be downloadable by USB cable to a computer using either Microsoft™ or Apple™ Operating Systems using Class 1/ O.E.M. supplied reporting software.

SEAT BELT WARNING SYSTEM

There shall be a seat belt indicator system supplied in the cab. The indicator system shall indicate seat belt use for each individual seating position when the seat is occupied, the seat belt remains unfastened and the parking brake is released.

A display panel shall be supplied in the dash area. The panel shall have an audible indicators and a red light display to indicate that a seat belt has not been fastened.

SEAT BELT WARNING SYSTEM - MONITOR

Mounted in the overhead console in the driver's area the indicator system shall indicate seat belt use for each individual seating position when the seat is occupied, the seat belt remains unfastened and the parking brake is released.

FRONT BUMPER

A 12" high heavy-duty 10 gauge, polished stainless steel, wraparound, 2-rib front bumper shall be provided the full width of the cab.

BUMPER EXTENSION

The front frame extension shall be bolted directly to the main rail. The extension and main rail joint shall have a 3/8" thick side plate for reinforcement. The completed apparatus must be able to be lifted at the front bumper without structural damage to the front extension for towing of a disabled vehicle.

The front bumper face shall extend 18 inches ahead of the front face of the cab skin.

TOW HOOKS

Two (2) chromed tow hooks shall be provided and shall be attached directly to the front frame extension under the bumper. These tow hooks shall be attached with two Grade 8 bolts with hardened washers and Grade "C" distorted thread locknuts.

GRAVELSHIELD

A gravelshield shall be installed filling the area above the extension rails. This gravelshield shall be constructed of .125" thick NFPA non-skid, bright, non-skid, aluminum treadplate. The gravelshield shall be supported at the front by the top flange of the stainless steel bumper. At the rear, the gravelshield shall be supported by a steel substructure.

AIR HORNS

Dual stutter tone air horns shall be recessed into the front bumper, one each side.

AIR HORN IGNITION CONTROL

To eliminate inadvertent operation the chassis air horns shall be operable only when the battery selector and ignition switch are in the "ON" position.

AIR HORN CONTROL SWITCH

The chassis air horns shall be controlled by a lanyard with a 'Y-chain'. The lanyard chain shall be mounted to the center of the overhead console within reach of both the driver and officer and shall terminate at the cab center.

AIR HORN OPERATION

The air horn and the electric horn shall be sounded simultaneously by depressing the horn button in the steering wheel.

EQ2B ELECTRONIC SIREN

A FEDERAL EQ2B electronic 200 watt speaker with the classic chrome "Q" grille shall be mounted recessed in the cab front 3-dimensional grille.

The 200-watt siren amplifier with digital output control head and microphone shall be mounted in the cab.

MASTER WARNING LIGHT CONTROL

To eliminate inadvertent operation the mechanical siren shall be operable only when the Master Warning Light switch is in the "ON" position and the parking brake is released.

SIREN CONTROL SWITCHES

One (1) foot switch for the siren shall be provided on the left side of the driver's side cab floor and one (1) on the right side of the officer's side cab floor.

The siren control shall be mounted on top of the engine doghouse within reach of the driver and officer.

ELECTRONIC CHASSIS OPERATOR'S MANUAL

An electronic Operator's Manual w/Parts List - One Set shall be provided with the chassis.

An electronic Electrical System Manual shall be provided.

- This manual shall provide complete wiring schematics for the vehicle.
- The manual shall be provided with diagrams of the vehicle showing the wiring harness routing within the vehicle. Each of these diagrams shall include the connectors between the harnesses that provide a hyperlink to a drawing of the actual connector where pin functions can be examined.
- Schematics for each system of the vehicle shall be provided with hyperlinks to the connectors for pin designations and to the vehicle drawings for harness location within the vehicle.

An electronic Air System Manual shall be provided.

- This manual shall provide complete air system schematics for the vehicle.
- The manual shall be provided with diagrams of the vehicle showing the air tubing routing within the vehicle.
- Schematics for each system of the vehicle shall be provided with hyperlinks to the tanks and valves and to the vehicle drawings for exact location within the vehicle.

MERITOR/ROCKWELL STANDARD AXLE WARRANTY

The vehicle shall be covered by Arvin/Meritor warranty that is in effect at the time of the vehicle production.

STANDARD TRANSMISSION WARRANTY

The chassis shall have a five (5) year unlimited mileage as defined in the Allison New Product Warranty.

ENGINE WARRANTY

The engine shall have the standard 5 year warranty from the engine manufacturer that is in effect at the time of the vehicle is placed into service.

CAB STRUCTURAL WARRANTY

The cab structure shall be warranted for a period of ten (10) years or fifty thousand 50,000 miles which ever may occur first. The warranty shall include conditional items listed in the detailed warranty document which shall be provided upon request.

CAB & CHASSIS WARRANTY

The chassis manufacturer shall provide a limited parts and labor warranty to the original purchaser of the custom built cab & chassis for a period of twelve (12) months, or the first 24,000 miles, whichever occurs first. The warranty period shall commence on the date the vehicle is delivered to the end user. The warranty shall include conditional items listed in the detailed warranty document which shall be provided upon request.

CAB ICC MARKER LIGHTING

Five (5) amber Whelen OS Series LED cab face mounted clearance lights shall be supplied, mounted above the windshield. These lights are to be mounted in a chrome flange.

Two (2) amber Whelen OS Series LED side clearance lights shall be supplied, one (1) each side mounted ahead of the front door. These lights are to be mounted in a chrome flange.

An amber diamond shaped reflector shall be mounted on the lower corner of each cab front door adjacent to the door hinge.

HEADLIGHTS

Four (4) rectangular halogen headlights shall be supplied.

When the parking brake is released and the master battery switch is in the on position, the head lamps shall be illuminated to 80% brilliance.

TURN SIGNALS

Two (2) rectangular Federal Signal, model QL64Z-TURN, LED turn signal lamps shall be mounted outboard of the front headlights on each side. These lights shall be amber in color.

BACK-UP ALARM

A solid state electronic backup alarm shall be installed on the rear of the apparatus and wired to the backup light circuit.

HEADLIGHT POSITION

The headlights shall be mounted in the upper position on the front of the cab to accommodate high profile front bumper items.

LOW LEVEL WARNING LIGHTS

Two (2) Code 3 4x6, model 65, warning lights with LED light heads shall be mounted on the front of the chassis above the headlights.

These two (2) lights fulfill the requirements for Lower Zone A lower level warning devices.

Both warning light lenses shall be red in color.

FRONT INTERSECTION LIGHTS

Two (2) Code 3 4x6, model 65, warning lights with LED light heads shall be mounted one (1) on each side of the front bumper/gravelshield with a Code 3 chrome plated flange.

These two (2) lights fulfill the requirements for Lower Zone B & D lower level warning devices.

Both warning light lenses shall be red in color.

CAB SIDE SCENE LIGHTS

There shall be side scene lights installed on the side of the cab between the front and rear cab doors on the raised roof section.

The lighting position(s) shall have two (2) Fire Research Focus model LED900-Q70 surface mount light shall be installed. The light shall be mounted with four (4) screws to a flat surface. It shall be 6 3/4" high by 9" wide and have a profile of less than 1 3/4" beyond the mounting surface. Wiring shall extend from a weatherproof strain relief at the rear of the light.

The light shall have twenty-four (24) white LEDs that generate a rated 7000 lumens at 12 or 24 volts DC. The lens shall redirect the light along the vehicle and out onto the working area. The light housing shall be aluminum with a chrome colored bezel.

The scene lights shall be operated by a switch located in the driver's area of the cab.

The scene light on the side of the cab shall be operated by either the front or the rear door on the same side of the cab opening.

FORWARD FACING BROW LIGHT

One (1) brow light shall be provided and mounted centered on the leading edge of the cab roof facing forward.

There shall be One (1) Fire Research Focus FCA800-Q14 Series roof mount lamphead(s) provided. The mounting bracket shall attach to the lighthouse chosen for the mounting position. Wiring shall exit from a weatherproof strain relief on the lamphead.

The lamphead shall have ten (10) ultra-bright white LEDs. It shall operate at 12/24 volts DC, draw 13/6.5 amps, and generate 14,000 lumens. The lamphead shall direct 50 percent of the light onto the action area while providing 50 percent to illuminate the working area. The lamphead angle of elevation shall be adjustable at a pivot in the mounting arm and the position locked with a round knurled locking knob. The lamphead shall incorporate heat-dissipating fins and be no more than 4" high by 11 1/2" wide. The lamphead and mounting arm shall be powder coated white. The floodlight shall be for fire service use.

The brow light shall have a white housing

One (1) 12-volt, switch(es) shall be located in the cab switch panel. The switch(es) shall control the 12-volt quartz lighting fixture(s) as selected.

VERTICAL CENTER OF GRAVITY / WEIGHT DISTRIBUTION

5/10/2016

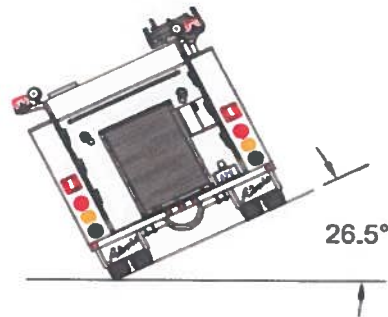
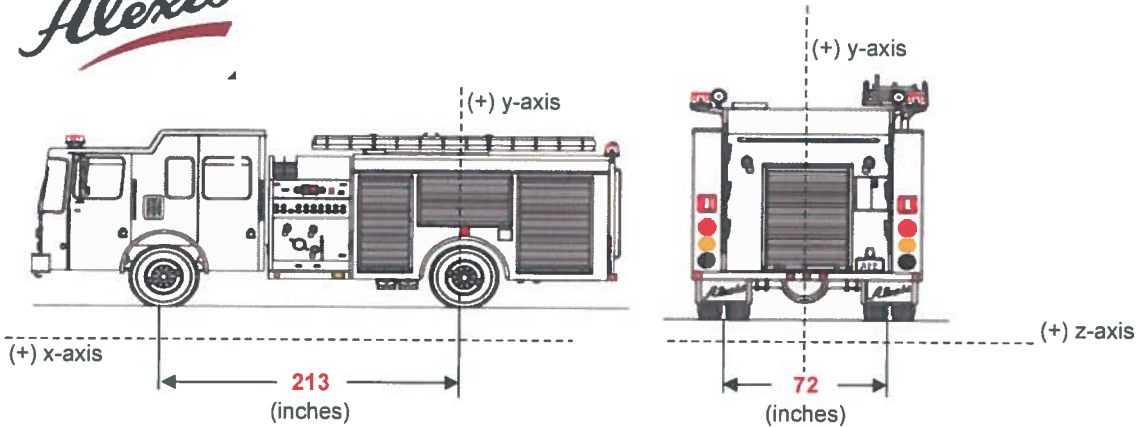

Contract No:
 Proposal Name: **AFE DEMO**
 Calculated By: **Melissa Tinkham**
 Approved By:
 Revision:
 Type of Chassis: **HME 1871-W-MFDxL 12RR**
 Type of Pump: **Darley PSM 1500gpm**
 Cab to Axle: **153**
 Tank Capacity: **1000**

| Item | Weight (lbs) | Coordinates Local C.G. (in) | | | % Rear | Weight (lbs) | |
|---------------------|--------------|-----------------------------|-------|------|--------|--------------|-------|
| | | z | x | y | | Front | Rear |
| Chassis | 18020 | 0 | 162 | 42 | 24% | 13700 | 4320 |
| Poly Tank (w/water) | 9250 | -3.25 | 11.75 | 72 | 94% | 510 | 8740 |
| Officer & Driver | 500 | 0 | 239 | 63 | -12% | 561 | -61 |
| Men & Equip. (cab) | 1000 | 0 | 169 | 63 | 21% | 793 | 207 |
| Pump Module | 1500 | 0 | 107 | 55 | 50% | 754 | 746 |
| Pump | 1400 | 0 | 89 | 48 | 58% | 585 | 815 |
| Body Module (SS) | 4750 | -6 | -6.5 | 66 | 103% | -145 | 4895 |
| Hose Bed | 1000 | 0 | -19.5 | 102 | 109% | -92 | 1092 |
| Add. Equip. front | 1000 | -3 | 48 | 56 | 77% | 225 | 775 |
| Add. Equip. Rear | 1500 | -3 | -54.5 | 56 | 126% | -384 | 1884 |
| Preconnects | 400 | 0 | 121 | 61 | 43% | 227 | 173 |
| | 0 | 0 | 0 | 0 | 0% | 0 | 0 |
| Ladder Rack | 300 | 47 | -6.5 | 99 | 103% | -9 | 309 |
| Suction Hose | 150 | 28 | -19 | 67.5 | 109% | -13 | 163 |
| Bumper Extension | 250 | 0 | 295.5 | 30 | -39% | 347 | -97 |
| | 0 | 0 | 0 | 0 | 0% | 0 | 0 |
| | 0 | 0 | 0 | 0 | 0% | 0 | 0 |
| | 0 | 0 | 0 | 0 | 0% | 0 | 0 |
| | 0 | 0 | 0 | 0 | 0% | 0 | 0 |
| | 0 | 0 | 0 | 0 | 0% | 0 | 0 |
| | 0 | 0 | 0 | 0 | 0% | 0 | 0 |
| Total | 41020 | Global Center of Gravity | | | | 17060 | 23960 |
| GAWR | 45740 | x | y | z | | 18740 | 27000 |
| Load as % of Total | 100% | -1.2 | 88.6 | 55.9 | | 42% | 58% |

Truck Tipping Angle: **32** degrees (Full Water Tank) **OK**

Maximum vertical center of gravity "z" = **57.60** **OK**

(Maximum "z" is 80% of the rear axle track width)

HOSE CAPACITIES

5/10/2016

Customer AFE DEMO
 Calculated By Melissa Tinkham

Drawing No. P-V51 Rev. _____
 Contract No. _____

HOSE BED

| | | | |
|---------|-------|--------------|--|
| Length | 134 | | |
| Width | 71 | | |
| Height | 18 | | |
| Cu. Ft. | 99.10 | 0.00 | |
| Total | | 99.10 | |

| | | | | |
|-----------|------|-------------|------|------|
| Hose Size | | | | |
| Amount | | | | |
| DF | 0 | 0 | 0 | 0 |
| Cu. Ft. | 0.00 | 0.00 | 0.00 | 0.00 |
| Total | | 0.00 | | |

MATTYDALES

| | | | |
|---------|------|-------------|------|
| Length | | | |
| Width | | | |
| Height | | | |
| Cu. Ft. | 0.00 | 0.00 | 0.00 |
| Total | | 0.00 | |

| | | | |
|-----------|------|-------------|------|
| Hose Size | | | |
| Amount | | | |
| DF | 0 | 0 | 0 |
| Cu. Ft. | 0.00 | 0.00 | 0.00 |
| Total | | 0.00 | |

CARTRIDGE LAYS

| | | | |
|---------|------|-------------|------|
| Length | 73 | 73 | |
| Width | 10 | 10 | |
| Height | 8 | 12 | |
| Cu. Ft. | 3.38 | 5.07 | 0.00 |
| Total | | 8.45 | |

| | | | |
|-----------|-------|-------------|------|
| Hose Size | 1 3/4 | 2 1/2 | |
| Amount | 200 | 150 | |
| DF | 26 | 41 | 0 |
| Cu. Ft. | 3.01 | 3.56 | 0.00 |
| Total | | 6.57 | |

HOSE TRAYS

| | | | |
|---------|------|-------------|------|
| Length | | | |
| Width | | | |
| Height | | | |
| Cu. Ft. | 0.00 | 0.00 | 0.00 |
| Total | | 0.00 | |

| | | | |
|-----------|------|-------------|------|
| Hose Size | | | |
| Amount | | | |
| DF | 0 | 0 | 0 |
| Cu. Ft. | 0.00 | 0.00 | 0.00 |
| Total | | 0.00 | |

HOSE WELLS

| | | | |
|---------|------|-------------|------|
| Length | 12 | | |
| Width | 26.5 | | |
| Height | 12 | | |
| Cu. Ft. | 2.21 | 0.00 | 0.00 |
| Total | | 2.21 | |

| | | | |
|-----------|-------|-------------|------|
| Hose Size | 1 3/4 | | |
| Amount | 150 | | |
| DF | 26 | 0 | 0 |
| Cu. Ft. | 2.26 | 0.00 | 0.00 |
| Total | | 2.26 | |

Standard Hose Dimensions per NFPA (2003 Edition)

| | | |
|------------------------------|-----|------------|
| 1 3/4" lays 3 1/4" wide | DF= | 26 |
| 2" lays 3 3/4" wide | DF= | 24 (ANGUS) |
| 2 1/2" lays 4 1/2" wide | DF= | 41 |
| 3" lays 5 1/4" wide | DF= | 50 |
| 4" lays 6 1/2" wide | DF= | 58 |
| 5" lays 8" wide - Angus | DF= | 96 |
| 5" lays 8-1/2" wide - Cotton | DF= | 102 |

