

3,000-GALLON TANKER #2501



TECHNICAL SPECIFICATIONS

Freightliner 114SD Chassis
450 HP Cummins L9 Engine
Allison 3000 EVS Automatic Transmission
Heavy Duty Stainless-Steel Body and Sub-Frame
Two (2) Person Cab
Stainless-Steel Intermediate Pump Module
Hale DSD 1250 GPM Split-Shaft Pump
Trident Priming Pump
FRC Pump Boss Pressure Governor & Monitoring System
Two (2) 6" Intakes, One (1) Left, One (1) Right
One (1) 5" Front Intake adapted to 6" NST with Low Level Strainer Preconnect
One (1) 2½" Gated Intake, Left Side
Two (2) 2½" FirePrograms Tank Fills, Rear One (1) Each side of the Dump
Two (2) 2½" Discharges, Left Side
One (1) 2½" Discharge, Right Side
One (1) 3" Discharge, Right Side, Adapted to 5" Storz
Mattydale Preconnect Module, One (1) 1½", One (1) 2½"
3000-Gallon Poly Tank
One (1) 10" Rear Newton Stainless-Steel Swivel Dump, Two (2) Side Dumps Above the Rear Axle
Hose Bed with LED strip Lighting and One (1) Vertical Divider
Satin Finish ROM Doors
One (1) 500# Roll-Out Tray with Vertical Pull-Out Tool Board, L1 Compartment

Four (4) Walk-Away Air Pack Brackets, R2 Compartment
Aluminum Rub Rails with LED Warning Lights & LED Undercarriage Lights
3000-Gallon Folding Tank Above Compartment Tops, Left Side
Two (2) Hard Suction Above Compartment Tops, Right Side
Ladder and Pike Poles Brackets, Right Side
AFE Rear Access Ladder
Two (2) Dual Air Bottle Wheel Well Compartments Left Side
Two (2) SCBA Air Pack Wheel Well Compartments, One (1) Each Side Above Axle
Two (2) Fire Extinguisher Wheel Well Compartments, Right Side
Progressive Dynamics Battery Charger with Kussmaul 120V 20A Super Auto Eject
Whelen Warning Light Package
FireTech Side and Rear Scene Lights
One (1) Back-up Camera with Cab Display
Diamond Grade Chevron Striping
10' 10" Overall Height
34' 8" Overall Length
236" Wheelbase
170.4" Cab to Axle
18,000 FAWR
44,000 RAWR
62,000 GVWR



CUSTOMER APPROVAL SIGNATURE: _____ DATE: _____

PIERSON-0003

IN THE EVENT THERE ARE DISCREPANCIES BETWEEN THE DRAWING AND THE SPECIFICATIONS THE SPECIFICATIONS SHALL PREVAIL.

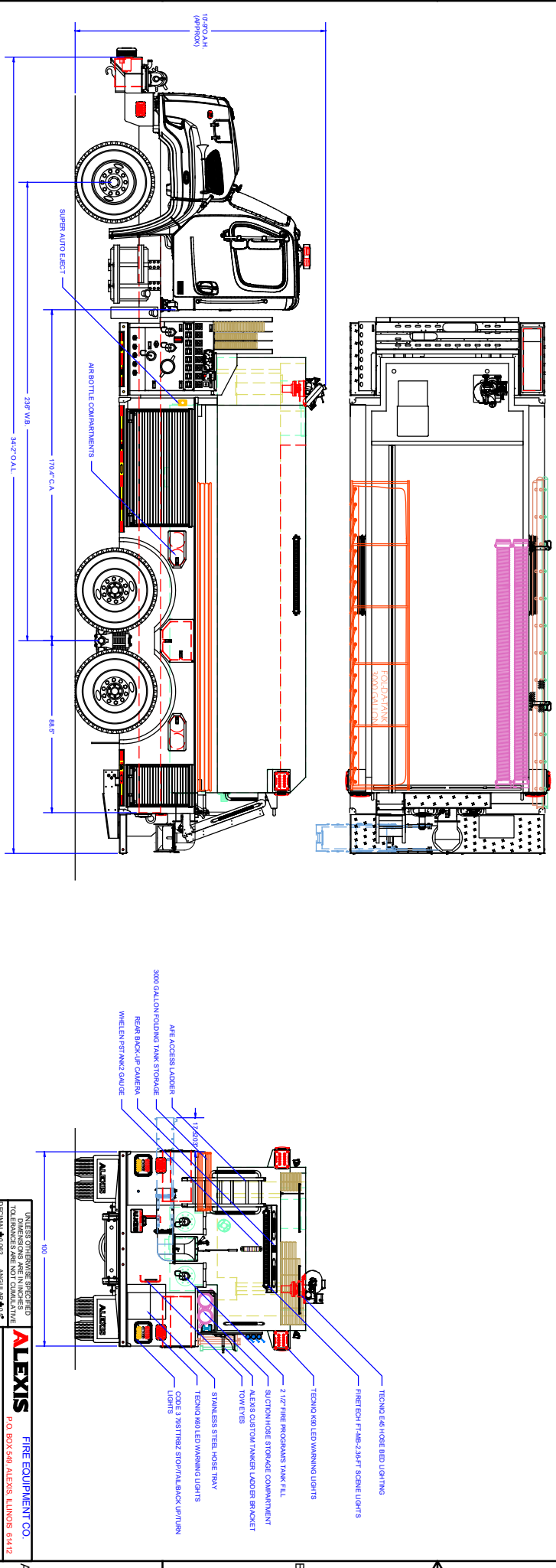
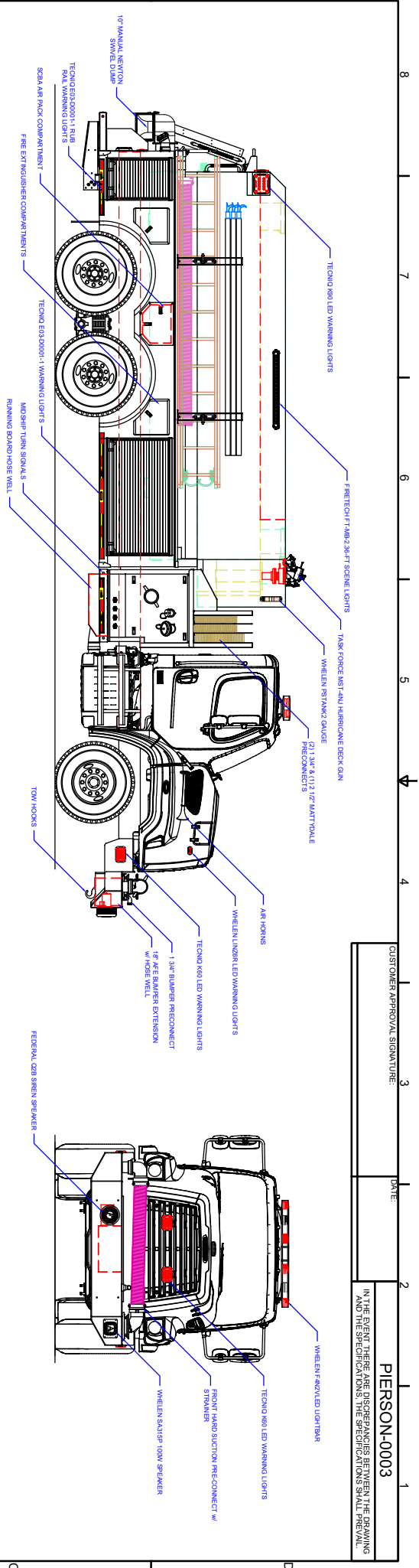

COMPARTMENT DIMENSIONS			
COMP #	DOOR OPENING SIZES	173 X 81	59\"/>
123 X 82	179\"/>		

REVISION HISTORY			
REV	DESCRIPTION	DATE	BY
02	CHANGE ORDER X-8	06/09/23	AJT
01	SALES REPORT	08/21	AMJ

Pump Info:	
Control Location:	Under Tank
Pump Drive:	Split Shaft
Tank Capacity:	3000
Pump Make:	Hale
Pump Model:	D90
Pump GPM:	1250

Apparatus Type: Tanker	
Chassis:	Flagliner - 2-Door
Tank Capacity:	3000
Material:	Stainless Steel

COMPARTMENT DIMENSIONS	
COMP #	DOOR OPENING SIZES
173 X 81	59\"/>
123 X 82	179\"/>

ALEXIS FIRE EQUIPMENT CO.	
P.O. BOX 549	ALEXIS, LINDSEY 6442
TANKER	
PIERSON VOLUNTEER FIRE DEPT.	
PIERSON, IN	
SIZE CODE:	PIERSON
CONTRACT #:	2501
DATE:	7/20/21
BY:	J. HENNING
SCALE:	1/2\"/>
SHEET:	1 OF 2