

# FLATBED BRUSH TRUCK

OGDEN ROYAL FIRE PROTECTION DISTRICT / ROYAL, ILLINOIS



# ALEXIS



THANK YOU TO THE OGDEN ROYAL FIRE PROTECTION DISTRICT FOR THE PURCHASE OF THIS UNIT.



## TECHNICAL SPECIFICATIONS

- Ford F-550 Chassis
- 7.3L V8 Gas Engine
- TorqShift 10-Speed Transmission
- Four (4) Person Cab
- Ranch Hand Black Brush Guard with Receiver and Winch Wiring
- Rear Receiver and Winch Wiring
- Louver Black Running Boards
- Midship Walkway with Two (2) Mansaver Bars
- Aluminum Tread Plate Storage Compartments, Three (3) Each Side, One (1) Rear
- One (1) 100' of 1" Booster Reel with Rewind Button, Top of Tank
- One (1) 1 1/2" Discharge, Rear
- Two (2) Folding Steps, Rear
- Progressive Dynamics Battery Charger with 120V Shoreline Connection
- Whelen Warning Light Package
- Two (2) Whelen Swivel Deck Lights, On Headache Rack
- Whelen Rear Scene Lights
- Whelen Electric Siren & 100W Speaker
- One (1) Back-up Camera with Cab Display
- 8' 3" Overall height
- 23' 3" Overall length
- 179.8" Wheelbase
- 60" Cab to Axle
- 7,500 FAWR
- 14,700 RAWR
- 19,500 GVWR



To view more photos and download spec sheet, please visit us at [AlexisFire.com](http://AlexisFire.com).

CUSTOMER APPROVAL SIGNATURE: \_\_\_\_\_ DATE: \_\_\_\_\_

**ROYAL-0002**

IN THE EVENT THERE ARE DISCREPANCIES BETWEEN THE DRAWING AND THE SPECIFICATIONS THE SPECIFICATIONS SHALL PREVAIL.

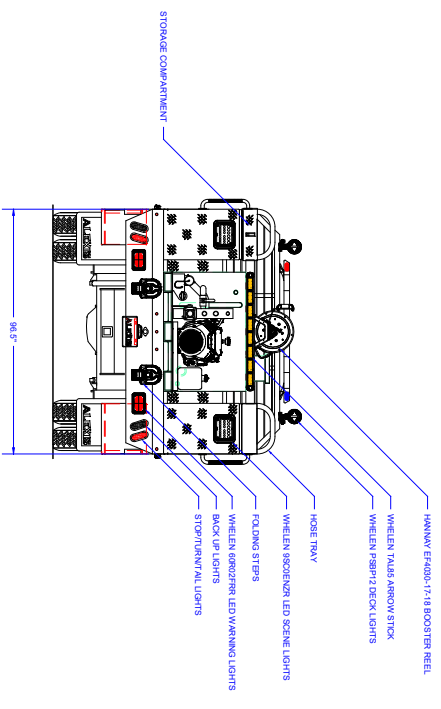
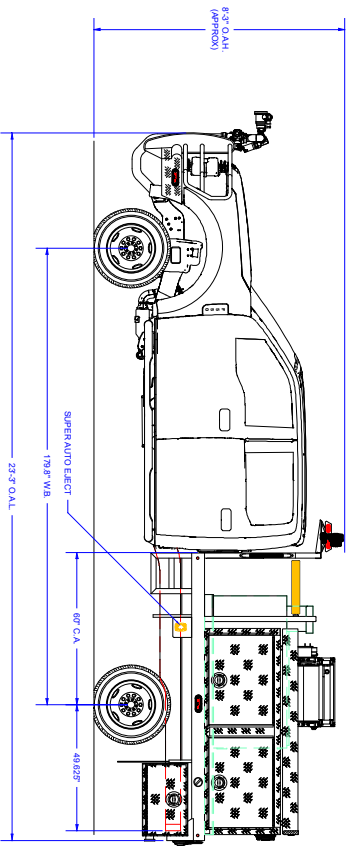
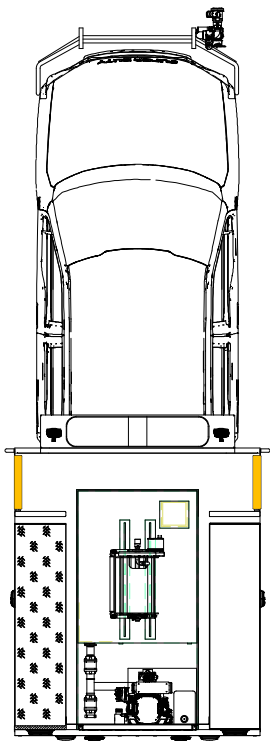
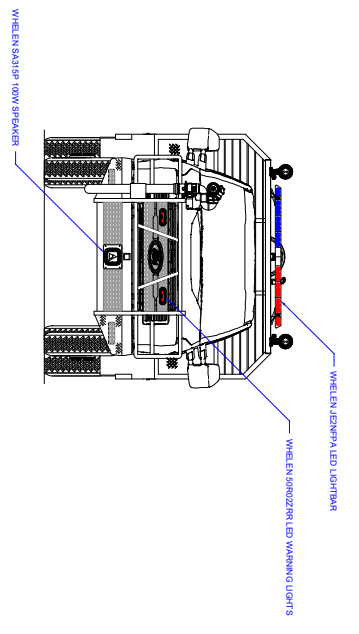
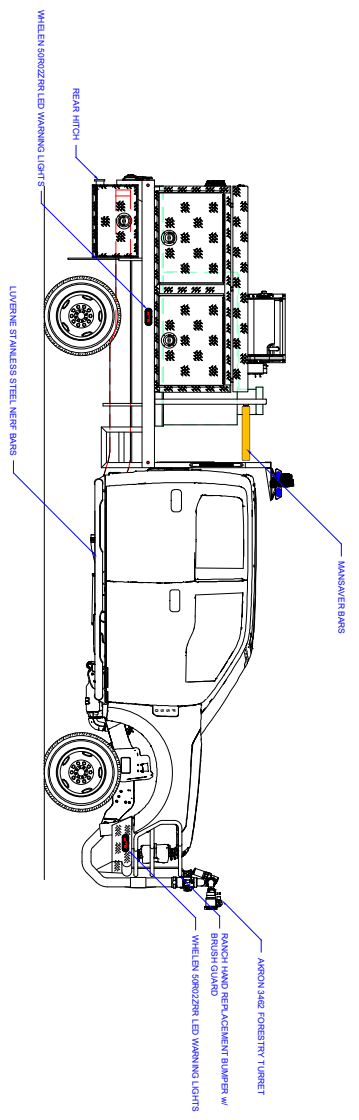

**COMPARTMENT DIMENSIONS**

COMP #	DOOR OPENING SIZES
L1 & L2	35" WIDE X 24" HIGH X 17" DEEP
R1 & R2	35" WIDE X 24" HIGH X 17" DEEP
UB1	25" WIDE X 24" HIGH X 12" DEEP
UBR	25" WIDE X 24" HIGH X 17" DEEP

UNLESS OTHERWISE SPECIFIED	SIZE	SCALE
DECIMAL: 4/10002	ANGULAR: 1/16"	1/2" = 1'
TOLERANCES ARE NOT DIMENSIONAL	FRACATIONAL: 1/16"	CONTRACT #
SK890	J. HENNING	SK890
DATE: 1/2/22	DATE: 1/2/22	DATE: 1/2/22
APPARATUS TYPE: Brush Truck	TANK CAPACITY: 300	MATERIAL: Aluminum
CONTROL LOCATION: Rear	PUMP MAKE: SMDI Gas	PUMP MODEL: OTHER
REVISION HISTORY	DATE: 1/2/22	BY: JWH
DESCRIPTION	DATE: 1/2/22	BY: JWH
SKETCH/PAINT	DATE: 1/2/22	BY: JWH

**ALEXIS FIRE EQUIPMENT CO.**  
 P.O. BOX 549, ALEXIS, ILLINOIS 61412

**BRUSH TRUCK**  
**OGDEN ROYAL FIRE P.D.**  
 ROYAL, IL

SK-D45