

1000-GALLON TOP-CONTROL PUMPER

VILLAGE OF NEW WASHINGTON / NEW WASHINGTON, OHIO



ALEXIS



THANK YOU TO THE VILLAGE OF NEW WASHINGTON
FOR THE PURCHASE OF THIS UNIT.

TECHNICAL SPECIFICATIONS

- International HV607 4-Door Chassis
- Cummins L9 350-HP Diesel Engine
- Allison 3000 EVS Transmission
- Heavy Duty Stainless-Steel Body and Sub-Frame
- Five (5) Person Cab Seating w/ Four (4) SCBA Seats
- ROM Roll-up Doors
- Hale QMax150 XS 1500-GPM Pump
- 1000-Gallon Poly Tank
- 20-Gallon Foam Tank w/ FoamPro Single Tank Foam System
- Two (2) Running Board Hose Wells, one (1) Each Side
- Two (2) 6" Suctions w/ Akron Butterfly Valves, one (1) Each Side
- Five (5) 2 1/2" Discharges, two (2) Left, one (1) Right, two (2) Rear
- Two (2) 3" Discharge, one (1) Right Side, one (1) Deck Gun
- One (1) 2 1/2" Gated Suction, Left Side
- Two (2) 1 1/2" Cartridge Lay Preconnects
- One (1) 2 1/2" Tank Fill, Rear
- Four (4) Dual Air Bottle Wheel Well Storage Compartments
- Progressive Dynamics On-board Battery Charger
- Kussmaul Super Auto Eject
- Floor Mounted Console for Emergency Switches w/ Binder Storage, Cab
- Whelen LED Warning Light and Scene Light Package
- Fire Research Spectra LED Telescopic Scene Lights
- Whelen Electronic Siren w/ 100-Watt Speaker
- Federal Q2B Siren
- Audiovox Back-up Camera System w/ 7" Monitor
- Ladder/Pike Pole/Suction Hose Storage, Through the Tank
- Diamond Grade Chevron Striping
- 9' 7" Overall Height
- 34' 3" Overall Length
- 272" Wheelbase
- 161" Cab to Axle
- 14,000 FAWR
- 30,000 RAWR
- 44,000 GVWR

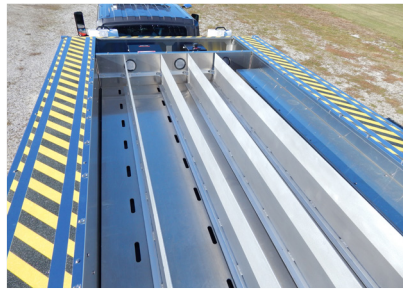

To view more photos and download spec sheet, please visit us at AlexisFire.com.

CUSTOMER APPROVAL SIGNATURE: _____ DATE: _____

WASHINGTON-0005

IN THE EVENT THERE ARE DISCREPANCIES BETWEEN THE DRAWING AND THE SPECIFICATIONS THE SPECIFICATIONS SHALL PREVAIL.

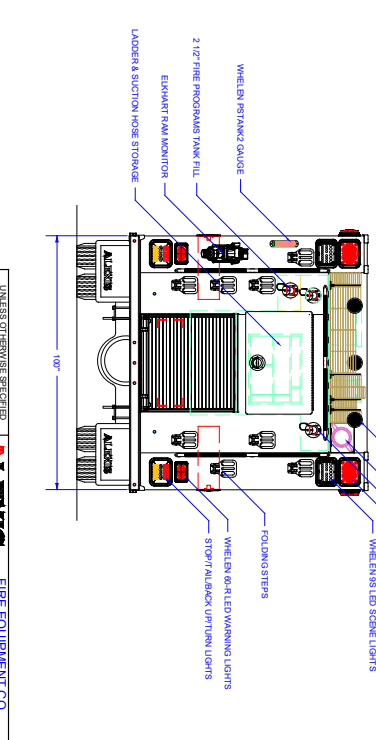
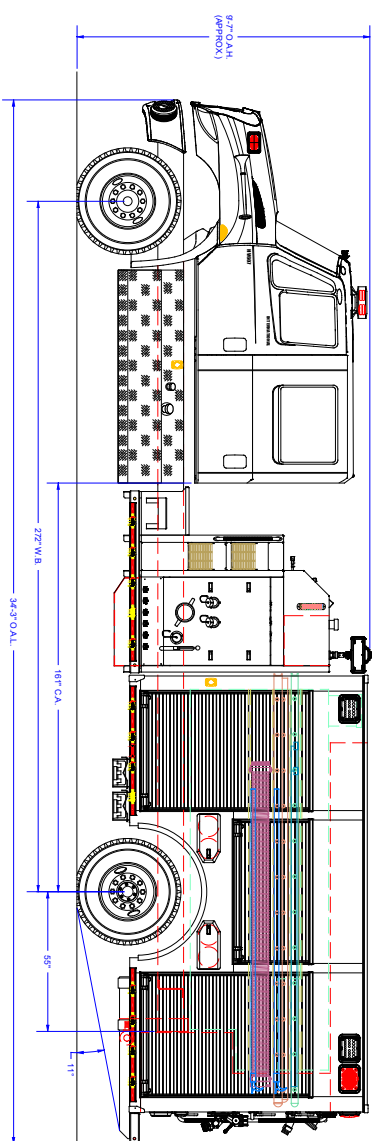
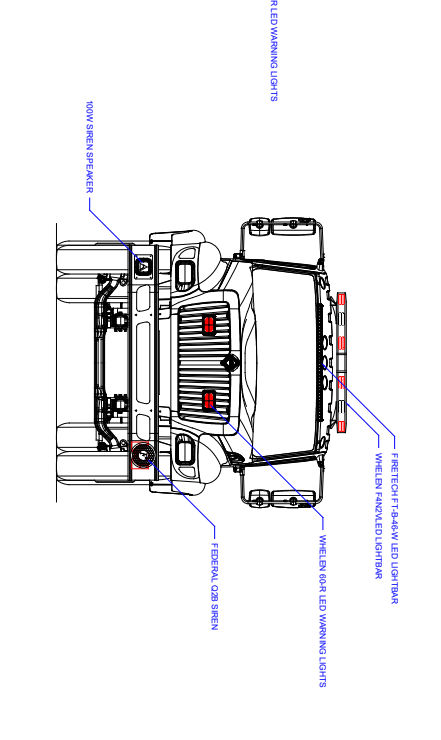
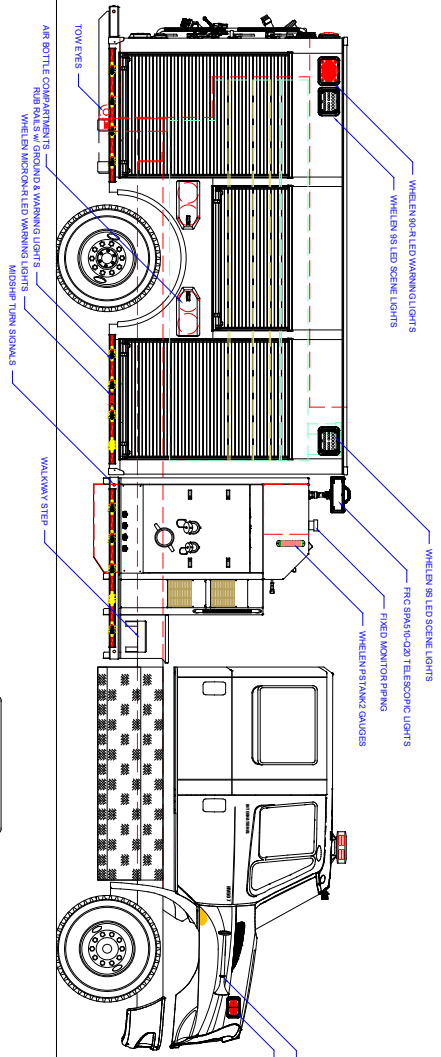

COMPARTMENT DIMENSIONS

| COMP # | DOOR OPENING SIZES |
|---------|--------------------------------|
| L1 & R1 | 41" WIDE X 62" HIGH X 28" DEEP |
| L2 & R2 | 54" WIDE X 25" HIGH X 28" DEEP |
| L3 & R3 | 42" WIDE X 62" HIGH X 28" DEEP |
| REAR | 38" WIDE X 32" HIGH X 28" DEEP |

UNLESS OTHERWISE SPECIFIED
 DIMENSIONS ARE IN INCHES
 DIMENSIONS ARE NOT DIMENSIONAL

ALEXIS FIRE EQUIPMENT CO.
 P.O. BOX 548, ALEXIS, ILLINOIS 64412

TOP MOUNT PUMPER
 NEW WASHINGTON FIRE
 NEW WASHINGTON, OH

DATE: 3/7/19
 SIZE: 1/2" = 1"
 CONTRACT #: 2405
 SHEET: 1 OF 2

REVISION HISTORY

| REV | DESCRIPTION | DATE | BY |
|-----|-----------------------|---------|-----|
| 01 | CHANGE ORDER A | 8/31/20 | JMT |
| 02 | SALES UPDATES | 9/16/20 | MJT |
| 03 | SALES UPDATES - AS SB | 4/11/21 | MJT |

Pump Info:

| | |
|-------------------|-----------------|
| Control Location: | Top |
| Pump Drive: | Spool Shaft |
| Chassis: | Navistar 4-Door |
| Tank Capacity: | 1000 |
| Pump Model: | Omni-XS |
| Pump GPM: | 7250 |

Apparatus Type: Pumper

| | |
|-----------|-----------------|
| Material: | Stainless Steel |
|-----------|-----------------|

COMP #

| | |
|---------|--|
| L1 & R1 | |
| L2 & R2 | |
| L3 & R3 | |
| REAR | |

DATE: 3/7/19

| | |
|-------|--------|
| DATE: | 3/7/19 |
|-------|--------|

CONTRACT #: 2405

| | |
|-------------|------|
| CONTRACT #: | 2405 |
|-------------|------|