

UTILITY BRUSH TRUCK #SK899

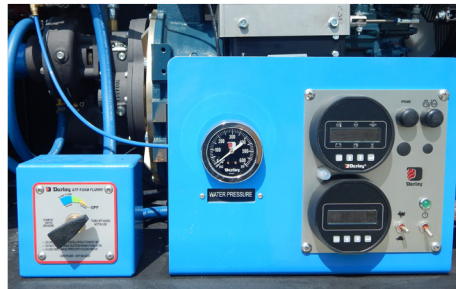

TECHNICAL SPECIFICATIONS

- Ford F-550 4x4 Super Duty Crew Cab Chassis
- 6.7L Power Stroke V8 Turbo Diesel Engine
- TorqShift 10-Speed Automatic Transmission
- Heavy Duty Aluminum Body and Subframe
- N-Fab Podium Black Cab Side Steps
- Rear Hitch with Trailer and Winch Wiring
- Ranch Hand Brush Guard with Hitch and Winch Wiring
- Warn Zeon 10S 10,000# Multi-Mount Winch with 100' Synthetic Rope
- Darley 1½ AGE 24K Direct Drive Skid Mounted Pump
- Kubota 24 HP Diesel Engine Interconnect to Chassis Fuel
- One (1) 2½" Gated Intake, Rear
- One (1) 2½" x 1½" Discharge, Rear Preconnected to Left Side Hose Tray
- One (1) 1½" Discharge, Rear
- Around the Pump Foam Inductor
- Akron 3462 125 GPM Front Forestry Turret with Joystick Cab Control
- 300 Gallon Poly Skid Tank with 10 Gallon Integral Foam Tank
- Three (3) Compartments Each Side with Painted Aluminum Pan Doors
- One (1) Aluminum Treadplate Hose Tray Left Side
- One (1) Aluminum Tread Plate Storage Compartment on the Right Side
- 12 Volt Electrical System with NFPA Compliant Warning Light Package
- Progressive Dynamics Battery Charger
- Kussmaul 120V 20A Super Auto Eject, Left Side Above Rear Wheel Well
- Whelen LED Warning and LED Scene Light Package
- Whelen 200W Siren and 100W Speaker
- Akron Scenestart LED Telescopic Lights, One (1) Each Side
- Code-3 Rear Deck Light
- FireTech HiViz 21" LED Brow Light Mounted on the Brush Guard
- One (1) Back-Up Camera with Dash Mounted Cab Display
- 8'-1" Overall height
- 24'-3" Overall length
- 179.8" Wheelbase
- 60" Cab to Axle
- 7,500 FAWR
- 14,700 RAWR
- 19,500 GVWR



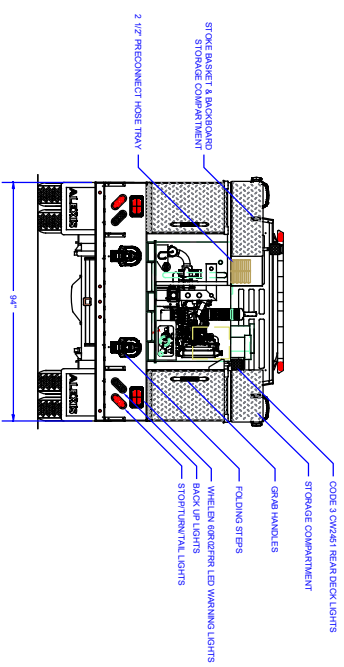
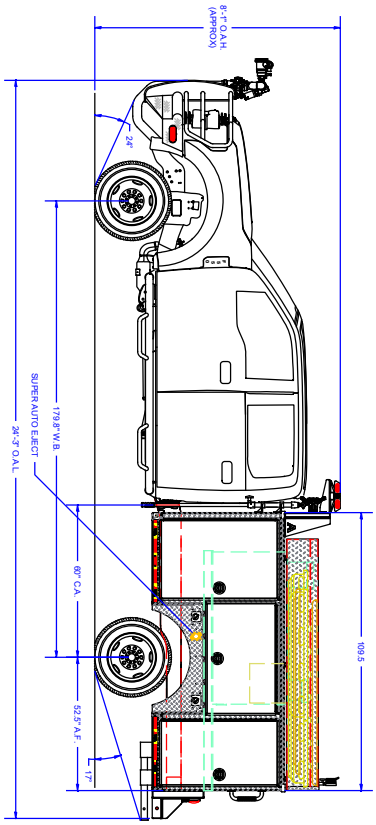
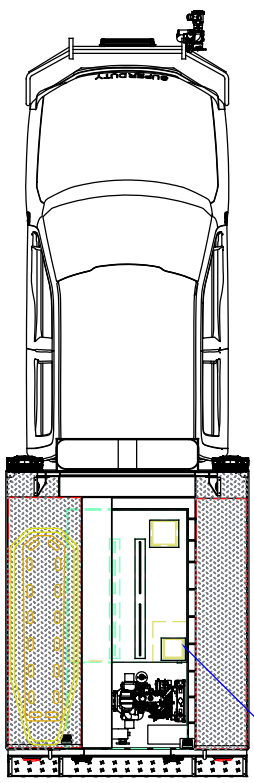
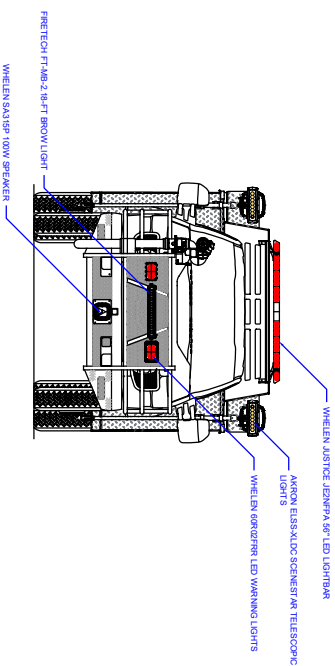
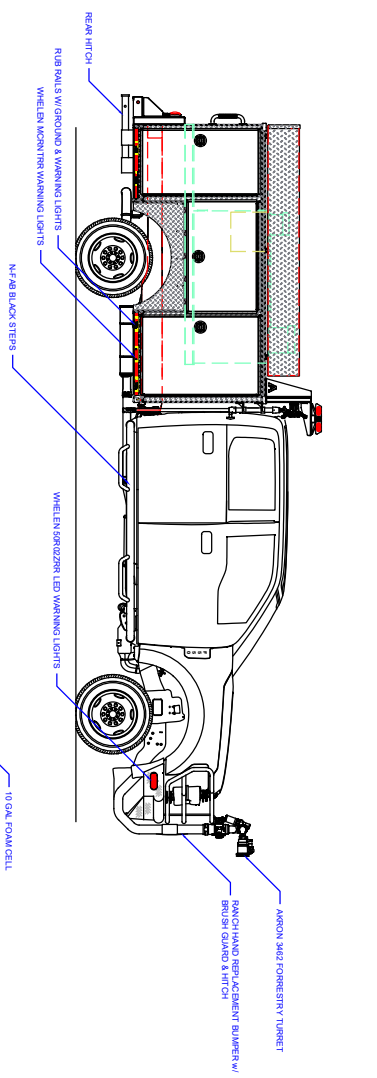

COMPARTMENT DIMENSIONS

COMP. #	DOOR OPENING SIZES
L1 & R1	28" WIDE X 24" HIGH X 17" DEEP
L2 & R2	35" WIDE X 26" HIGH X 17" DEEP
L3	35" WIDE X 48" HIGH X 17 1/2" DEEP
R3	28" WIDE X 48" HIGH X 17 1/2" DEEP

Pump Info:

Control Location:	Rear
Pump Drive:	None
Pump Make:	Smid Diesel
Pump Model:	Pump 300
Material:	Aluminum

UNLESS OTHERWISE SPECIFIED DIMENSIONS ARE IN INCHES. DIMENSIONS ARE NOT TO SCALE. LINE WEIGHTS ARE NOT TO SCALE. LINE WEIGHTS ARE NOT TO SCALE. LINE WEIGHTS ARE NOT TO SCALE.

ALEXIS FIRE EQUIPMENT CO.
 P.O. BOX 469, ALEXIS, ILLINOIS 61412

UTILITY TRUCK
 NEW HOLLAND FPD
 NEW HOLLAND, IL

SIZE: 1/2" = 1"
 CONTRACT # SK899
 SHEET 1 OF 2

REV	DESCRIPTION	DATE	BY	CHK
01	SALES POINT	10/22/23	AND	

REV	DESCRIPTION	DATE	BY	CHK
01	SALES POINT	10/22/23	AND	