

TOP MOUNT MAP PUMPER

MOORLAND TOWNSHIP FIRE DEPARTMENT / RAVENNA, MICHIGAN



ALEXIS



THANK YOU TO THE MOORLAND TOWNSHIP FIRE DEPARTMENT FOR THE PURCHASE OF THIS UNIT.



TECHNICAL SPECIFICATIONS

- Spartan MFD Metro Star
- 450 HP Cummins L9
- Allison 3000 EVS Automatic Transmission
- Six (6) Person cab with five (5) SCBA seats
- 24" Front Bumper Extension with one (1) 1 1/2" Preconnect and Center Hose Well
- Progressive Dynamics Battery Conditioner with VIAIR Auxiliary Compressor
- Heavy Duty Aluminum Subframe & Aluminum Body
- ROM Series IV Satin Finish Roll Up Doors
- 1000 Gallon Poly Water Tank
- Top Control Pump Module
- Hale QMAX-XS 150 1500 GPM Split Shaft Pump
- One (1) 5" Front Suction
- Two (2) 6" Suctions, one (1) each side
- One (1) 2 1/2" Gated Suction, Left Side
- Four (4) 2 1/2" Discharges, Two (2) Left, One (1) Right, & One (1) Rear
- One (1) 3" Discharge, Right Side
- One (1) 3" Fixed Monitor Piping Over Pump Compartment
- Two (2) 1 1/2" Cartridge Lay Preconnects
- Low Hose Bed with One (1) Divider
- Electronically Controlled Ladder Rack
- Suction Hoses, Pike Poles and Attic Ladder Storage Through the Tank
- Aluminum Rub Rails with LED Ground Lights and LED Warning Lights
- Duradeck Tile on floors of the compartments
- Whelen LED Warning Light Package
- Federal Q2B mechanical Siren, front bumper
- Fire Tech 12 Volt Scene Lights Package
- Diamond Grade Chevron Striping, Rear
- 9' 10" Overall Height
- 34' Overall Length
- 208" Wheelbase
- 154" Cab to Axle
- 20,000 FAWR
- 27,000 RAWR
- 47,000 GVWR

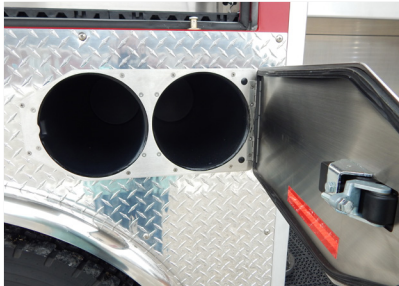

To view more photos and download spec sheet, please visit us at AlexisFire.com.

CUSTOMER APPROVAL SIGNATURE: _____ DATE: _____

AFE-2416

IN THE EVENT THERE ARE DISCREPANCIES BETWEEN THE DRAWING AND THE SPECIFICATIONS, THE SPECIFICATIONS SHALL PREVAIL.

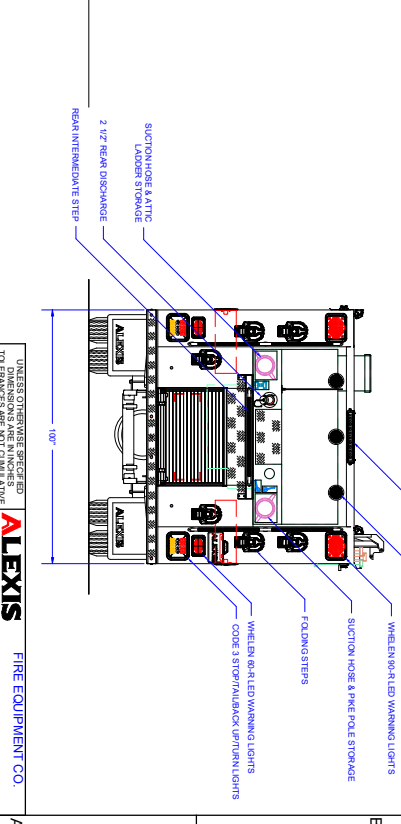
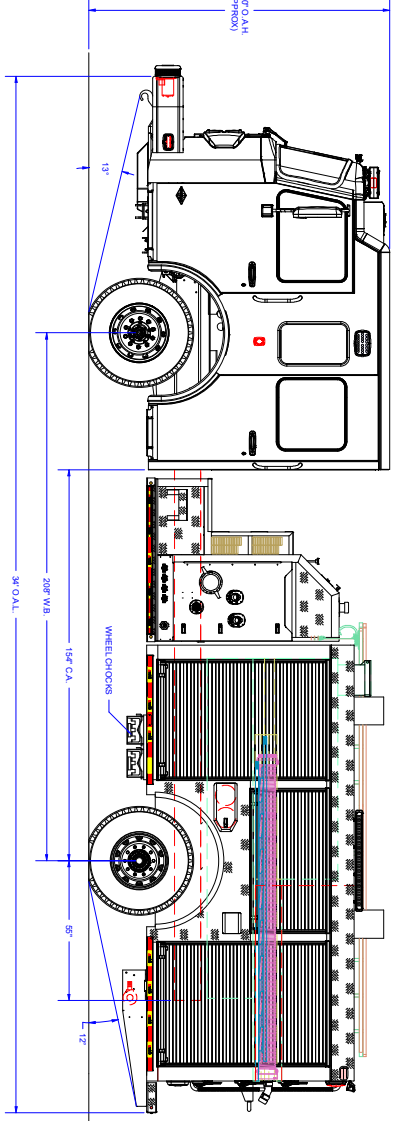
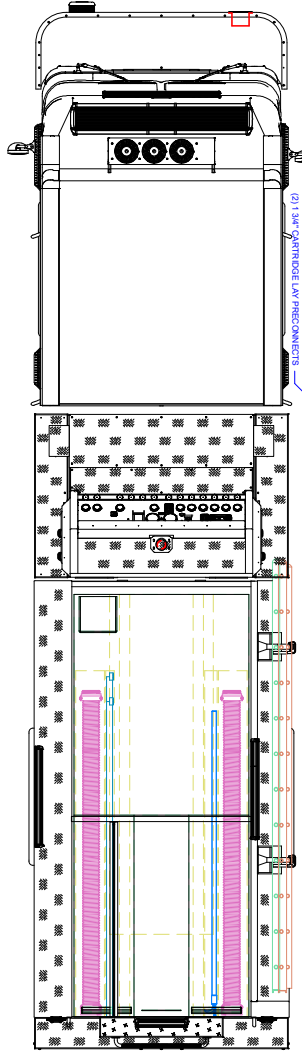
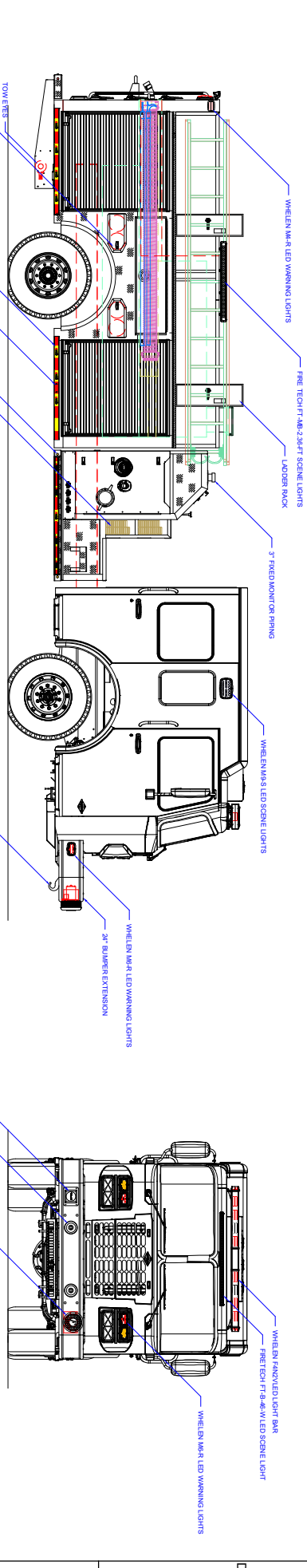

COMPARTMENT DIMENSIONS

COMP #	DOOR OPENING SIZES
L1 & R1	45" WIDE X 62" HIGH X 1226" DEEP
L2 & R2	54" WIDE X 25" HIGH X 1226" DEEP
L3 & R3	46" WIDE X 62" HIGH X 1226" DEEP
REAR	36" WIDE X 21" HIGH X 28" DEEP

REV	DESCRIPTION	DATE	BY
1	REVISION HISTORY		

ALEXIS FIRE EQUIPMENT CO.
 P.O. BOX 549, ALEXIS, ILLINOIS 61412

ALEXIS FIRE EQUIPMENT COMPANY
 ALEXIS, IL

UNLESS OTHERWISE SPECIFIED:
 DIMENSIONS ARE IN INCHES AND DECIMAL FRACTIONS.
 DIMENSIONS ARE NOT TO SCALE.
 THE COPYRIGHT OF THIS DRAWING AND DESIGN AND ALL RIGHTS THEREIN ARE RESERVED BY ALEXIS FIRE EQUIPMENT CO.

SIZE SCALE	DWG NO
D 1/2" = 1'	MAP-A02