

2,000-GALLON TANKER #2516



TECHNICAL SPECIFICATIONS

Freightliner 114SD 2-Door Chassis
450 HP Cummins L9 Diesel Engine
Allison 3000 EVS Automatic Transmission
Heavy-Duty Stainless Steel Body and Subframe
Two (2) Person Cab
Waterous 1250 gpm PTO Pump
Trident Automatic Air Prime System
FRC Pump Boss Pressure Governor & Monitoring System
Two (2) 6" Intakes, One (1) Each Side with Akron 7982 Revolution Butterfly Valves
One (1) 2½" Gated Intake Left Side
One (1) 2½" Gated Intake Right Side
One (1) 4" FirePrograms Tank Fill, Rear Left of Dump
One (1) 2½" Discharge Left Side
One (1) 2½" Discharge Right Side
One (1) 2½" Discharge Rear
One (1) 4" Discharge Rear Adapted to 4" Storz
2,000-Gallon Poly Tank
ROM Satin Finish Roll-Up Doors
Four (4) Folding Steps, Rear

Hose Bed with One (1) Divider, LED Lights, Hypalon Cover
Ladder Brackets Left Side
One (1) Hard Suction Gutter on Left Compartment Tops
Two (2) Hard Suction Storage Hose Bed Divider Compartment
Zico Hydraulic 2,100-Gallon Folding Tank Bracket with One (1) Hard Suction Storage Right Side
Progressive Dynamics Battery Charger, L1 Compartment
Kussmaul 20 Amp Super Auto-Eject 120V Shoreline Connection, Left Front Body Post
Whelen Warning and Scene Light Package
Whelen Traffic Advisor Light
Diamond Grade Chevron Striping
10' Overall height
27' 1" Overall length
196" Wheelbase
130.5" Cab to Axle
16,000 FAWR
31,000 RAWR
47,000 GVWR



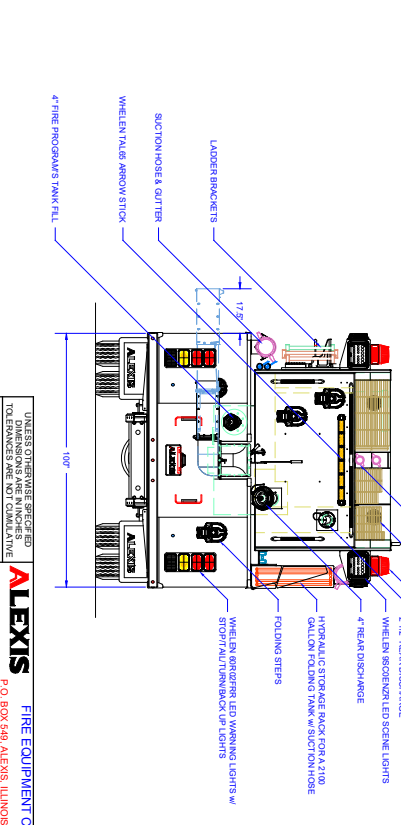
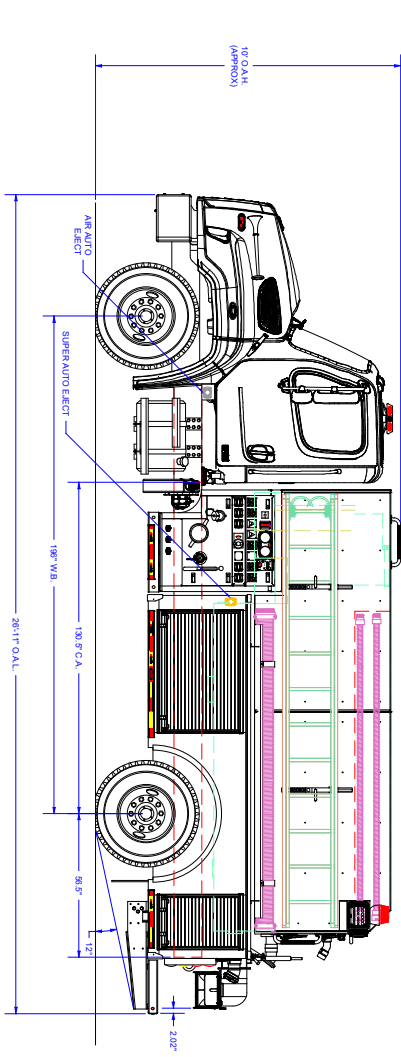
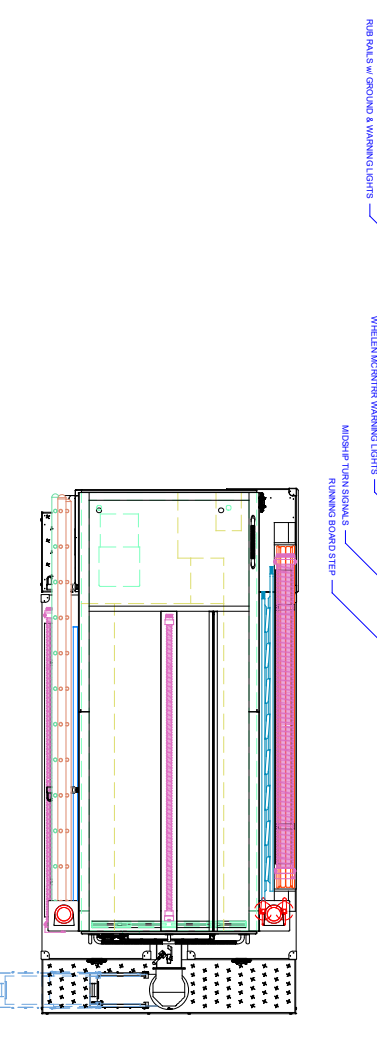
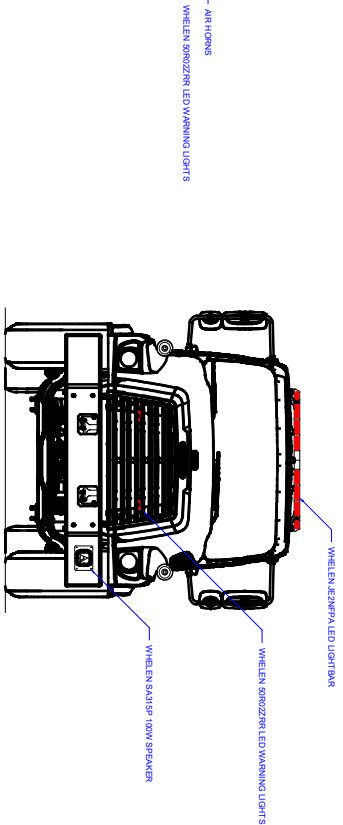
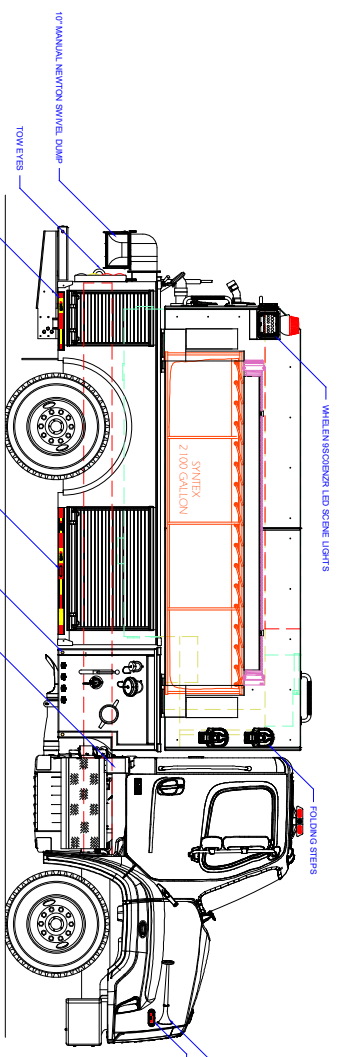

COMPARTMENT DIMENSIONS

Pump Info:		Apparatus Type: Tanker	
Control Location:	Under Tank	Chassis:	Faigliner - 2-Door
Pump Drive:	PTO	Tank Capacity:	2000
Pump Make:	Waldous		
Pump Model:	CX Series		
Pump GPM:	1250		

REV	DESCRIPTION	DATE	SWN	Material: Stainless Steel	

ALEXIS FIRE EQUIPMENT CO.

P.O. 609/649, ALEXIS, ILLINOIS 61412

DESIGNAL: #10102	ANGUS, A: 1015
FRACCTIONAL: 1.116	METRIC: 2.8 mm
The copyright of this drawing and design and the right of production therein is held by Alexis Fire Equipment Co.	
3500XN	J. HENNING
1/20/22	1/22 = 1"
D	CONTRACT # 2516
SHEET 1	OF 2

MINERAL POINT FD
MINERAL POINT, WI
T-L53