

2000-GALLON EQUALIZER TANKER



KNOXVILLE TOWNSHIP FIRE DEPARTMENT KNOXVILLE, IOWA

TECHNICAL SPECS

- Peterbilt 348, 2-Door Chassis
- Paccar PX-9, 330-HP Diesel Engine
- Allison 3000 EVS Automatic Transmission
- Heavy Duty 3/16" Aluminum Body
- ROM Roll Up Doors
- 2000-Gallon Poly Tank
- One (1) 2 ½" Fireman's Friend Tank fill, rear
- One (1) Newton 10" square electric swivel Dump with 36" manual extension
- Darley LDM, 1000-GPM Pump
- Pump operator's panel under tank left side
- Three (3) 2 ½" Discharges, two (2) left side and one (1) right side
- Two (2) 3" Discharges, one (1) right side and one (1) over pump for Deck Gun
- Two (2) 1 ½" Mattydale Preconnects, ahead of tank
- One (1) 2 ½" Gated Suction, left side
- On Spot Automatic Tire chains
- Folding Tank Rack storage, top of compartments on the right side
- Suction Hose storage, top of compartments left side
- Ladder brackets, right side
- Two (2) Walk-Away Air pack brackets, right side
- Progressive Dynamics on-board battery charger
- Kussmaul Super Auto Eject 120-volt shoreline
- Kussmaul Air Eject
- Floor mounted console for Emergency switches, cab
- Whelen Electronic Siren with 100-watt Cast Products speaker
- Four (4) Whelen LED Scene lights, one (1) each side and two (2) rear
- Whelen LED Warning Light Package
- Chevron pattern striping, rear
- 9' 9" Overall height
- 28' 8" Overall length
- 229" Wheelbase
- 159.2" Cab to Axle
- 14,600 FAWR
- 30,000 RAWR
- 44,600 GVWR



To view more photos,
visit www.AlexisFire.com

WE WOULD LIKE TO THANK
THE KNOXVILLE TOWNSHIP FIRE
DEPARTMENT FOR THEIR BUSINESS.



CUSTOMER APPROVAL SIGNATURE: _____ DATE: _____

ALEXISD-0001

IN THE EVENT THERE ARE DISCREPANCIES BETWEEN THE DRAWING AND THE SPECIFICATIONS, THE SPECIFICATIONS SHALL PREVAIL.

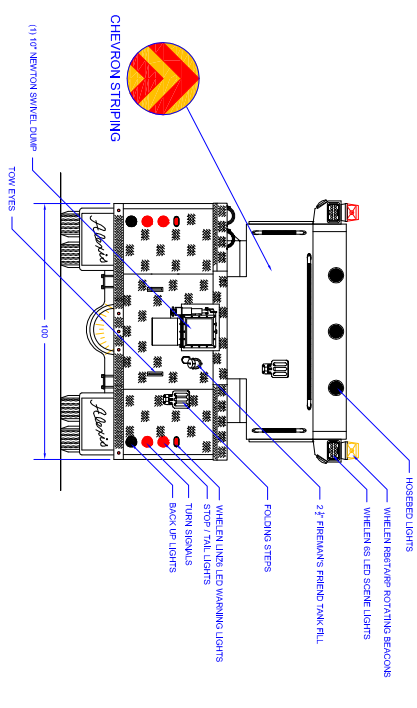
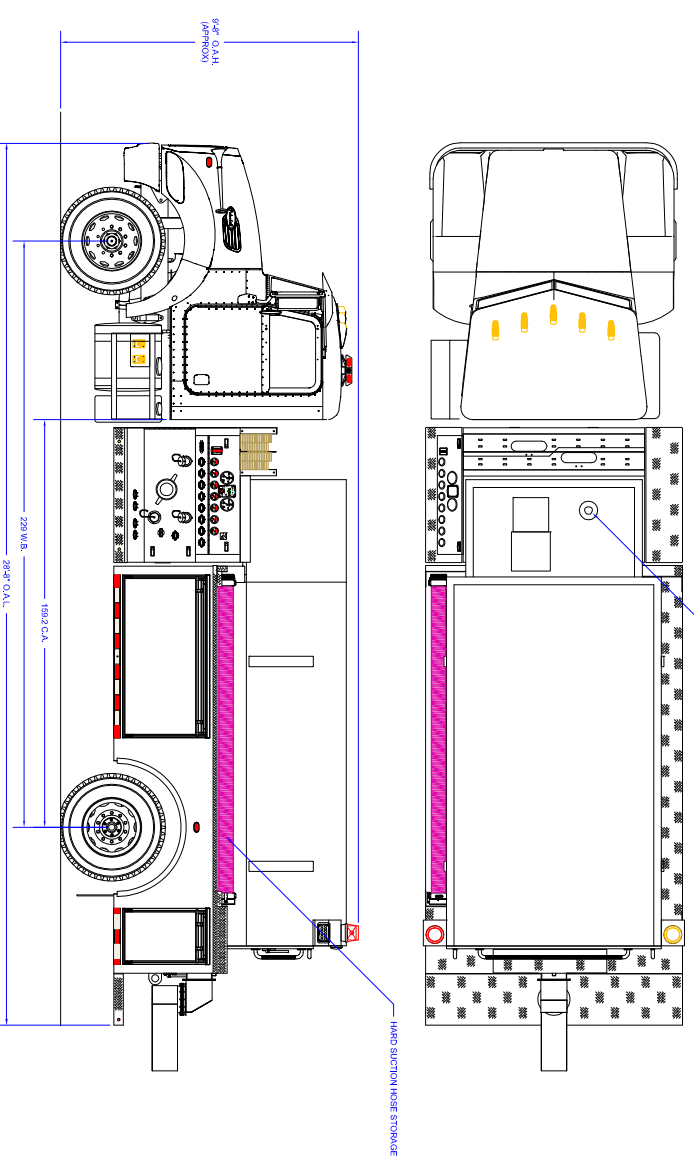
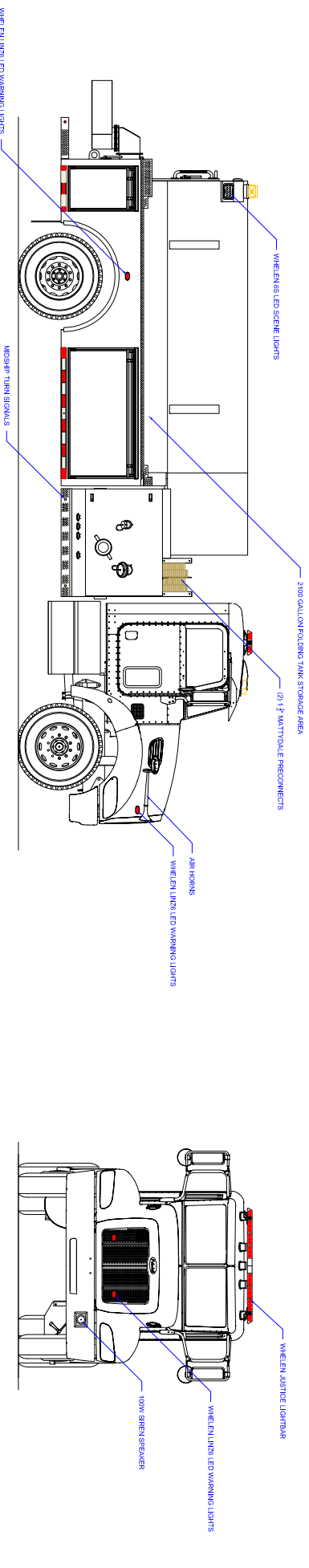

COMPARTMENT DIMENSIONS

COMP #	DOOR OPENING SIZES
COMP #1	61" WIDE X 27" HIGH X 25" DEEP
LT & RT	19" WIDE X 27" HIGH X 25" DEEP
LT & RT	

PUMP INFO		APPARATUS TYPE: Tanker	
Control Location:	Under Tank	Chassis:	Freightliner 2-Door
Pump Drive:	Shift Shaft	Tank Capacity:	2000
Pump Make:	Daiwy		
Pump Model:	PSM		
Pump GPM:	1000	Material:	Aluminum

UNLESS OTHERWISE SPECIFIED	
DRAWN	M. TINKHAM 11/21/14
CHECKED	
DATE	11/21/14
SCALE	1/2" = 1'
CONTRACT #	2266

DIMENSIONS AND FINISHES	
TOTAL LENGTH	ANGULAR 4.0°
FINISH	ANGULAR 4.0°
PROTECTORIAL	316 METRIC ± 0.6 mm

FIRE EQUIPMENT CO.	
P.O. BOX 569 ALEXIS, ILLINOIS 61412	
EQUALIZER TANKER	
ALEXIS FIRE EQUIPMENT COMPANY	
ALEXIS, ILLINOIS	
SIZE	3000
MODEL	TE-A30
SHEET	1 OF 2