

TANKER #2470



TECHNICAL SPECIFICATIONS

- Heavy Duty Stainless Steel Body and Sub-Frame
- ROM Series IV Satin Finish Roll-Up Doors
- Two (2) compartments Each side with Dual LED Strip Lights
- 3000 Gallon Fol-Da-Tank Storage, Above Right side compartments
- Storage for Two (2) 10' lengths of hard suction hose, Above Left compartments
- Waterous CXV 1250 GPM PTO Pump
- Alexis Custom Stainless Steel Cast Manifold System with 10 Year Warranty
- Trident Air Prime System
- Stainless Steel Side Mount Pump Module
- Two (2) Hose Wells, One (1) Each side of Pump Module
- FRC Pump Boss Pressure Governor & Monitoring System
- Two (2) 6" Intakes, One (1) Each Side
- One (1) 2½" Gated Intake, Left Side
- One (1) 2½" and One (1) 4" Adapted to 5" Storz Rear Tank Fills
- Two (2) 2½" Discharges, Left Side
- One (1) 2½" Discharge, Right Side
- One (1) 3" Discharge, Right Side Adapted to 5" Storz
- One (1) 1½" and One (1) 2½" Mattydale Preconnects
- One (1) Newton 10" Rear Manual Swivel Dump
- 3000-Gallon Poly Tank
- Wetside Hosebed with Rear Fill Tower
- Two (2) Dual Air Bottle Compartments, One (1) Each side Ahead of Wheel Wells
- One (1) Center Console with Switches
- Progressive Dynamics Battery Charger, L1 Compartment
- Kussmaul 20 Amp Super Auto-Eject 120V Shoreline Connection, Left Front Body Post
- Whelen Warning and Scene Light Package
- One (1) Rear Mounted Audiovox Backup Camera with Cab Display
- Four (4) Folding Steps, Rear
- International HV607 Conventional Chassis
- Cummins L9 360 HP Engine
- Allison 3000 EVS Automatic Transmission
- 9' 11" Overall Height
- 32' 4" Overall Length
- 238" Wheelbase
- 170.9" Cab to Axle
- 16,000 FAWR
- 40,000 RAWR
- 56,000 GVWR



CUSTOMER APPROVAL SIGNATURE: _____ DATE: _____

AFE-2470

IN THE EVENT THERE ARE DISCREPANCIES BETWEEN THE DRAWING AND THE SPECIFICATIONS, THE SPECIFICATIONS SHALL PREVAIL.

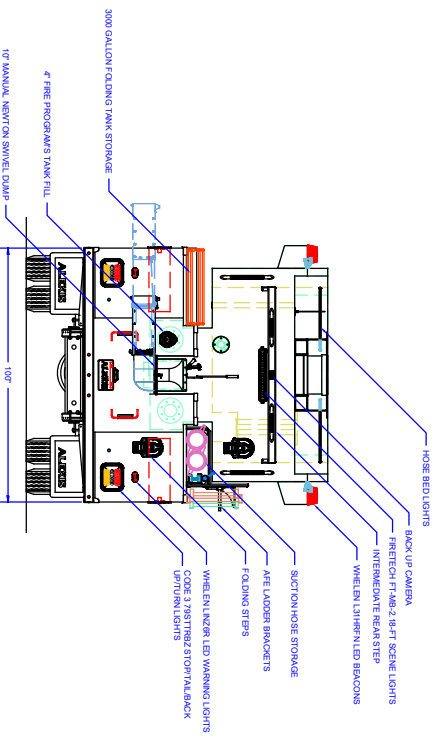
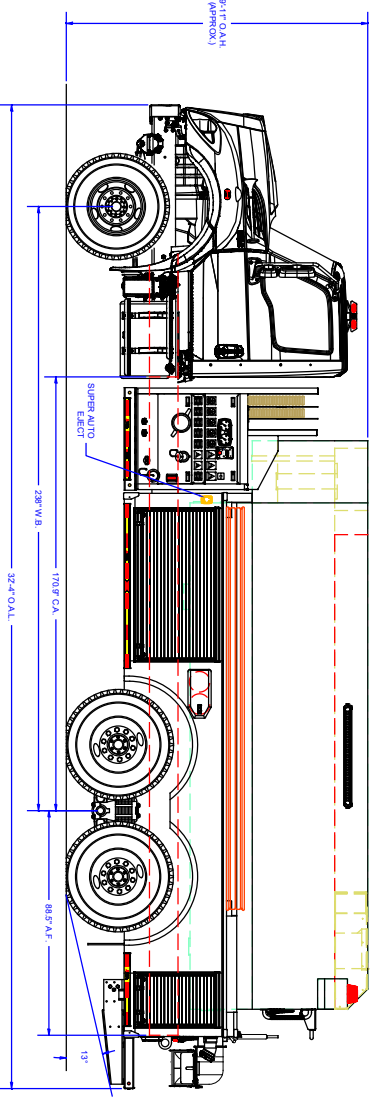
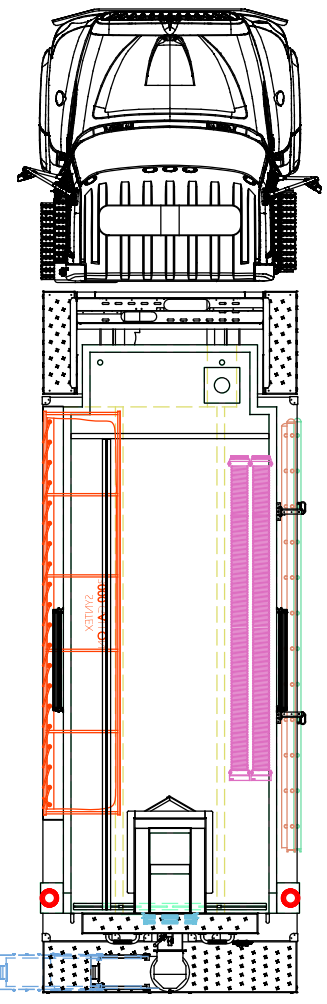
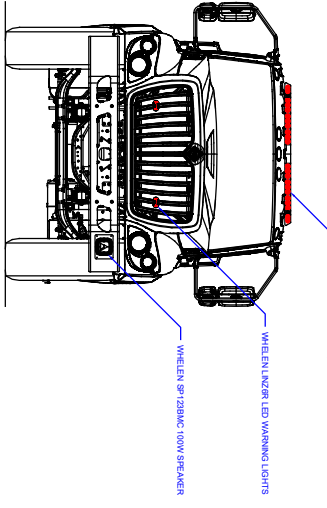
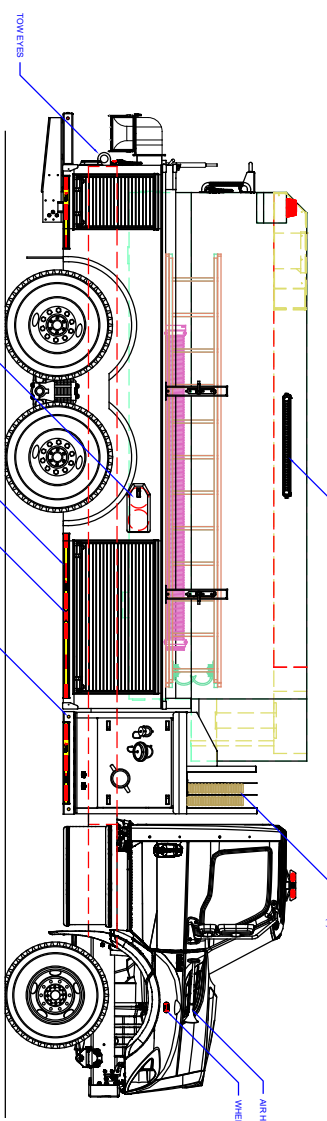

COMPARTMENT DIMENSIONS

COMP #	DOOR OPENING SIZES		UNLESS OTHERWISE SPECIFIED	
L13 & R1	58" WIDE X 27" HIGH X 25" DEEP	DRAWING: 1/4" = 1"		
L2 & R2	19" WIDE X 27" HIGH X 25" DEEP	CONTRACT #		
MATERIAL: STAINLESS STEEL		DATE: 6/20/22		
APPARATUS TYPE: TANKER		PROJECT: T1-184		
CHASSIS: NAVISTAR 2-DOOR		SHEET: 1 OF 2		
TANK CAPACITY: 3000		TANKER		
TANK MAKE: WABTEC		KENTLAND FIRE DEPT		
TANK MODEL: CXV97A		KENTLAND, IN		
PUMP MAKE: WABTEC		FIRE EQUIPMENT CO.		
PUMP MODEL: T250		P.O. BOX 568, ALEXIS, ILLINOIS 62412		
PUMP GPM: 1750		TEL: 618-232-3333		
CONTROL LOCATION: UNDER TANK		FAX: 618-232-3333		
CONTROL MAKE: WABTEC		WWW.ALEXISFIRE.COM		
CONTROL MODEL: T250		© 2022 ALEXIS FIRE EQUIPMENT CO.		
CONTROL GPM: 1750		ALL RIGHTS RESERVED		

REVISION HISTORY

REV	DESCRIPTION	DATE	BY