

2000-GALLON TANKER #2401

GRAHAMSVILLE FIRE DISTRICT / GRAHAMSVILLE, NEW YORK



ALEXIS



THANK YOU TO THE GRAHAMSVILLE FIRE DISTRICT FOR THE PURCHASE OF THIS UNIT.



TECHNICAL SPECIFICATIONS

- Freightliner 114SD 2-Door Chassis
- Cummins L9 450-HP Diesel Engine
- Allison 3000 EVS Automatic Transmission
- On Spot Chains
- Heavy Duty Stainless-Steel Body & Subframe
- Hale DSD 125 1250 GPM- PTO Pump
- Stainless Steel Plumbing & Manifold
- 2000-Gallon Wetside Poly Tank
- One (1) 6" Steamer Inlet, Left Side
- Four (4) 2 1/2" Discharges, Two (2) Left and Two (2) Right
- One (1) 3" Discharge, Right Side
- One (1) 2 1/2" Gated Suction, Left Side
- Two (1) 1 1/2" Mattydale Preconnects
- One (1) 2 1/2" Tank Fill, Rear
- Newton 10" Manual Swivel Dump w/ 36" Extension
- Floor Mounted Console for Emergency Switches
- Progressive Dynamics PD2140 Battery Charger
- Kusmaul Super Auto Eject
- Whelen LED Warning Light Package
- Whelen Electronic Siren w/ 100-watt Speaker
- Whelen LED Scene Light Package
- Whelen 12 V Pioneer Spot/Flood Telescopic Lights
- Folding Tank Storage, Right Side Compartment Top
- Suction Hose Storage, Left Side Compartment Top
- Diamond Grade Chevron Stripping, Rear
- 9' 9" Overall Height
- 26' 6" Overall Length
- 200" Wheelbase
- 134" Cab to Axle
- 14,600 FAWR
- 30,000 RAWR
- 44,600 GVWR



To view more photos and download spec sheet, please visit us at AlexisFire.com.

CUSTOMER APPROVAL SIGNATURE: _____ DATE: _____

IN THE EVENT THERE ARE DISCREPANCIES BETWEEN THE DRAWING AND THE SPECIFICATIONS, THE SPECIFICATIONS SHALL PREVAIL.

AFE-2401

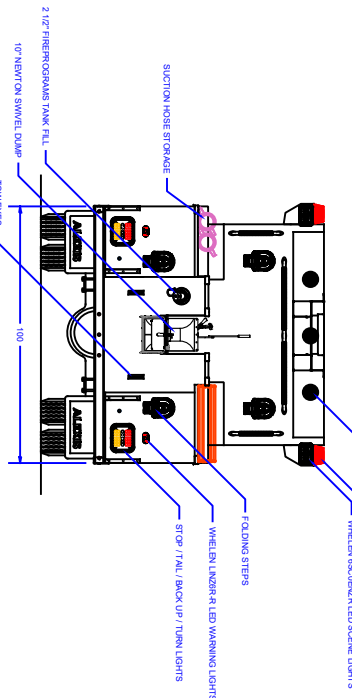
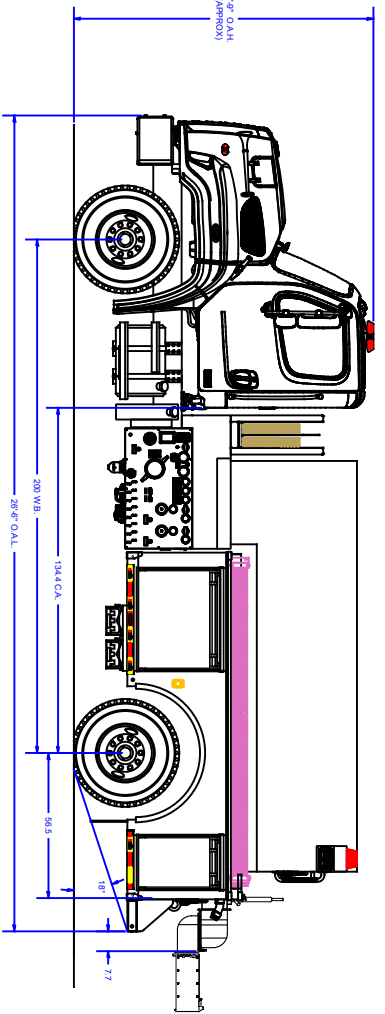
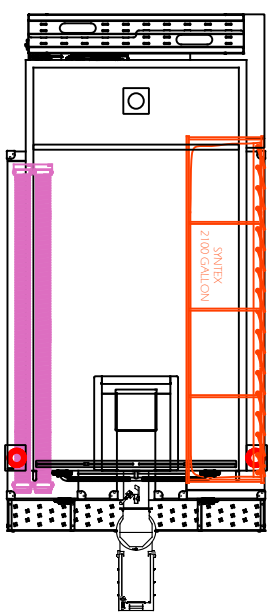
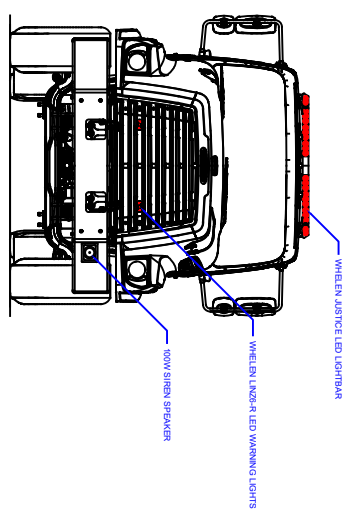
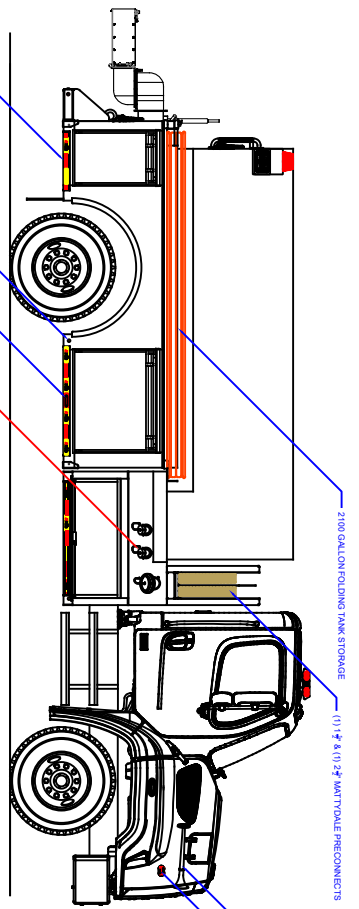

COMPARTMENT DIMENSIONS

REV#	DESCRIPTION	DATE	BY
1	REVISIONS/REVISIONS	02/15/2024	MSD
2	REVISIONS/REVISIONS	02/15/2024	MSD
3	REVISIONS/REVISIONS	02/15/2024	MSD
4	REVISIONS/REVISIONS	02/15/2024	MSD
5	REVISIONS/REVISIONS	02/15/2024	MSD
6	REVISIONS/REVISIONS	02/15/2024	MSD

Pump Unit:	Control Location:	Linear Tank	Apparatus Type:	Tanker
Pump Make:	Chassis:	Freightliner 2-Door	Tank Capacity:	2000
Pump Model:	Material:	Stainless Steel	COMP #	L1 & R1
Pump GPM:	Material:	Stainless Steel	COMP #	L2 & R2
DOOR OPENING SIZES				
38" WIDE X 27" HIGH X 28" DEEP				
19" WIDE X 27" HIGH X 28" DEEP				

ALEXIS FINE EQUIPMENT CO.
 P.O. BOX 518 ALEXIS ILLINOIS 61412

TANKER
 GRAHAMSVILLE FIRE DIST
 GRAHAMSVILLE, NY

SIZE SCALE: 1/2" = 1'
 CONTRACT # 2401
 SHEET 1 OF 2