

# CUSTOM 3000-GALLON WETSIDE TANKER



**FOX LAKE FIRE PROTECTION DISTRICT  
INGLELAKE, ILLINOIS**



## TECHNICAL SPECS

- Spartan Metro Star SMFD flat roof Chassis
- Cummins ISL9, 450-HP Diesel Engine
- Allison 3000 EVS Automatic Transmission
- Four (4) Man cab seating with three (3) SCBA seats
- Heavy Duty Stainless Steel Body with ROM Roll Up Doors
- 3000-Gallon Wetside Poly Tank
- Two (2) 4" Fireman's Friend Tank fills, rear
- One (1) Newton 10" square electrically controlled swivel tank dump, rear
- Hale DSD150, 1500-GPM Pump
- Left side intermediate pump operator's control panel
- Three (3) 2 1/2" Discharges, one (1) each side and one (1) rear
- Two (2) 3" Discharges, one (1) each side
- Two (2) 2 1/2" Gated Suction, one (1) each side
- One (1) 2 1/2" and two (2) 1 1/2" Mattydale Preconnects, behind cab
- 6" Front Bumper Extension with 5" Suction through bumper
- Two (2) Dual bottle Air bottle compartments, one (1) each side wheel well
- Ziamatic hydraulic folding tank bracket for 3000-gallon tank, left side
- Four (4) Pike pole storage tubes, left side
- Ziamatic Electrically controlled ladder rack, right side
- Two (2) Suction Hose storage, one (1) each side
- Turtle Tile on floors of compartments
- Kussmaul 1200 on-board battery charger
- Kussmaul Super Auto Eject 120-volt shoreline connection
- Audiovox back-up camera system with 7" color monitor
- Federal Q2B mechanical Siren and two (2) Air Horns, front bumper
- Whelen Electronic Siren with Cast Products 100-watt speaker
- 12" Chrome plated brass bell electrically controlled, front bumper
- Six (6) Whelen LED Scene lights, two (2) each side and two (2) rear
- Whelen LED Warning Light Package
- Diamond Grade Chevron pattern striping, rear
- 9' 11" Overall height
- 34' 8" Overall length
- 227" Wheelbase
- 182" Cab to Axle
- 23,000 FAWR
- 44,000 RAWR
- 67,000 GVWR

# ALEXIS

THANK YOU TO FOX LAKE FIRE PROTECTION DISTRICT FOR THE PURCHASE OF THIS UNIT.  
To view more photos and download flyer, please visit us at [AlexisFire.com](http://AlexisFire.com).

CUSTOMER APPROVAL SIGNATURE:	DATE:	<b>FOX LAKE-1003</b>
IN THE EVENT THERE ARE DISCREPANCIES BETWEEN THE DRAWING AND THE SPECIFICATIONS, THE SPECIFICATIONS SHALL PREVAIL.		

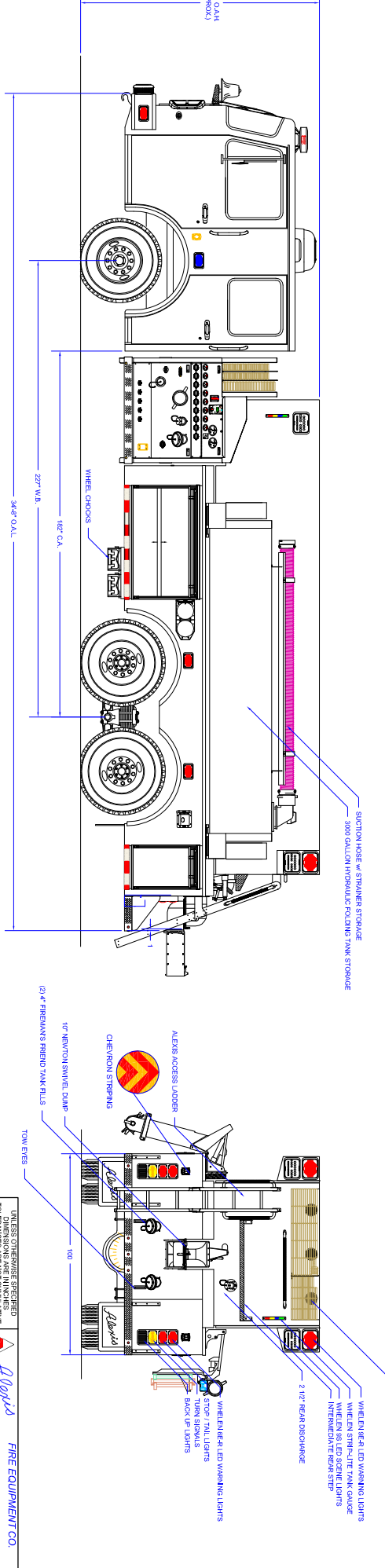
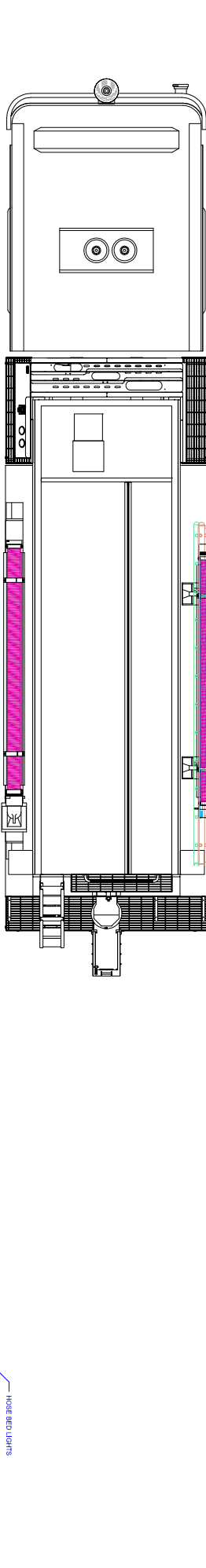
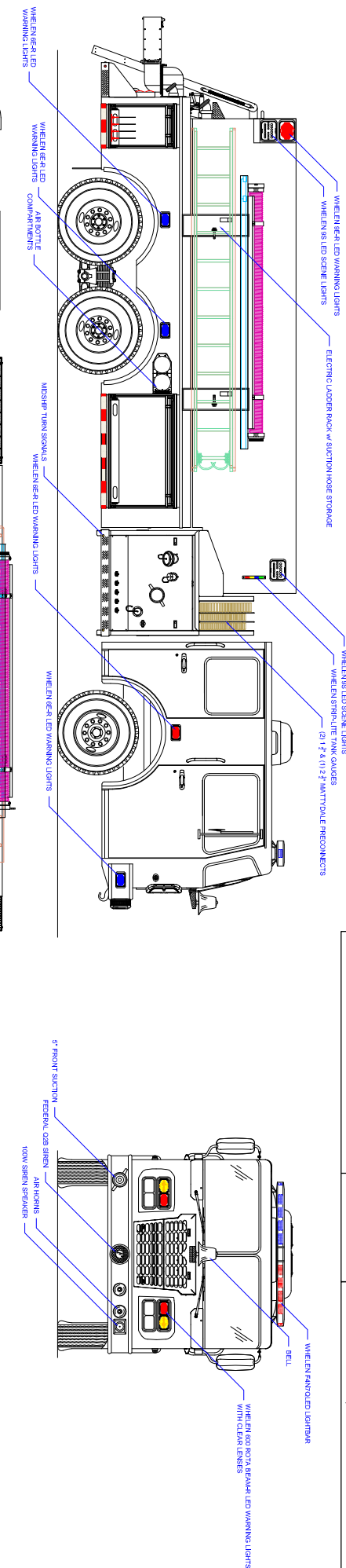

<b>COMPARTMENT DIMENSIONS</b>			
DRIVEN	M/TN/DHAM	3/16/18	SIDE BOULE
CONTROL UNIT	M/TN/DHAM	3/16/18	SIZE BOULE
CONTROL UNIT	M/TN/DHAM	3/16/18	SIZE BOULE
CONTROL UNIT	M/TN/DHAM	3/16/18	SIZE BOULE
CONTROL UNIT	M/TN/DHAM	3/16/18	SIZE BOULE

REGISTRATION HISTORY	DATE	SO	APPARATUS TYPE	TANKER
REGISTRATION HISTORY	DATE	SO	APPARATUS TYPE	TANKER
REGISTRATION HISTORY	DATE	SO	APPARATUS TYPE	TANKER
REGISTRATION HISTORY	DATE	SO	APPARATUS TYPE	TANKER
REGISTRATION HISTORY	DATE	SO	APPARATUS TYPE	TANKER

