

CUSTOMER APPROVAL SIGNATURE: _____ DATE: _____

SPECIAL TANKER 200-0004

IN THE EVENT THERE ARE DISCREPANCIES BETWEEN THE DRAWING AND THE SPECIFICATIONS, THE SPECIFICATIONS SHALL PREVAIL.

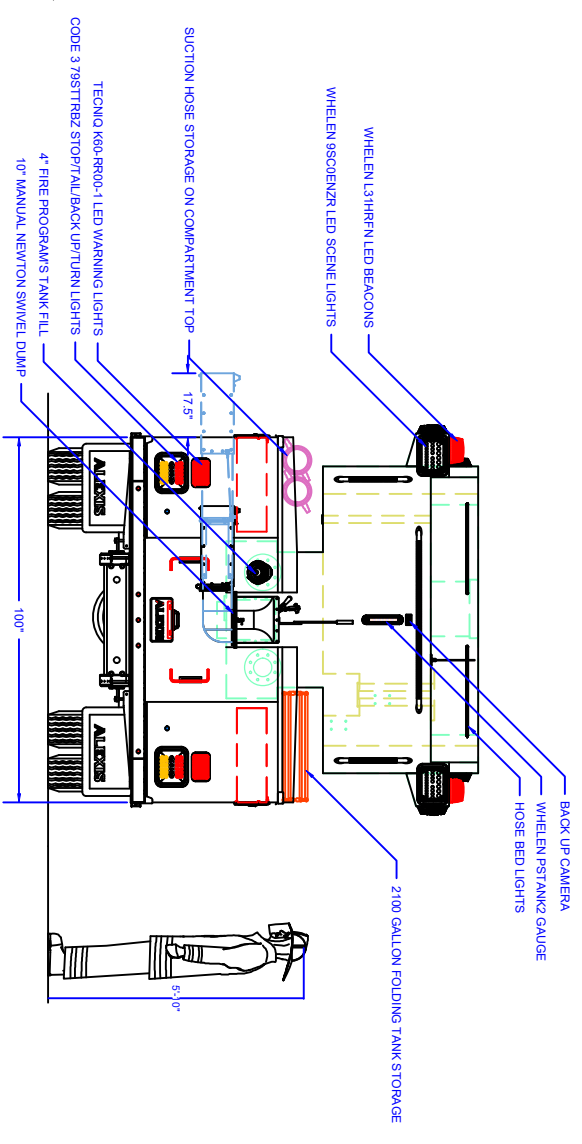
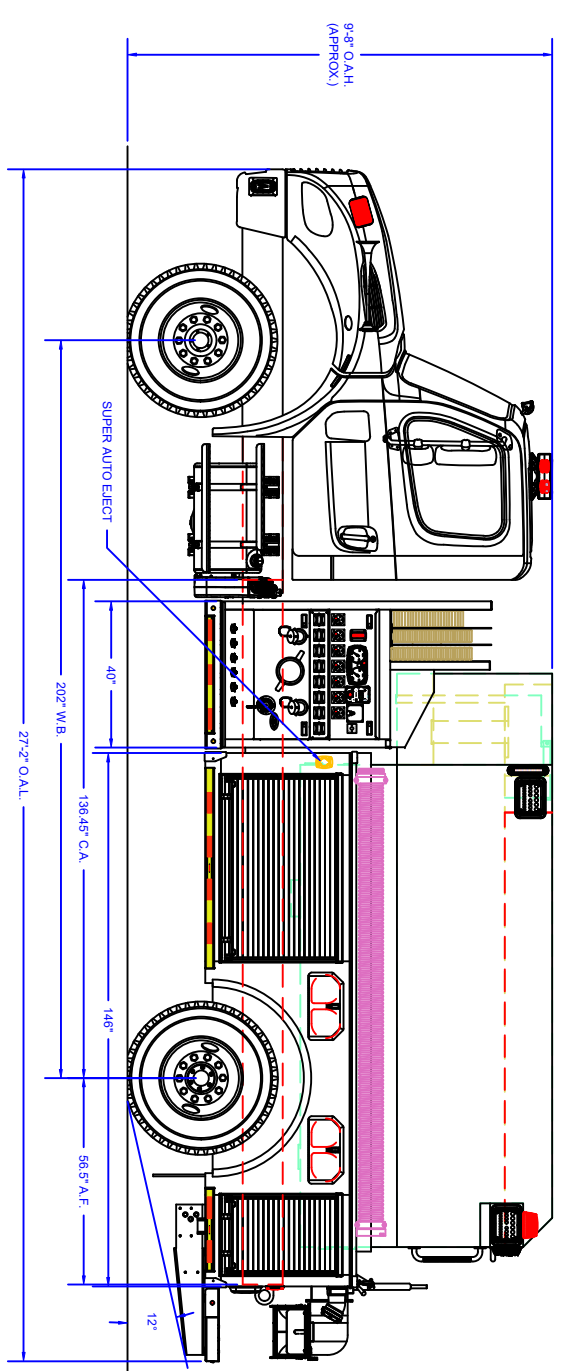
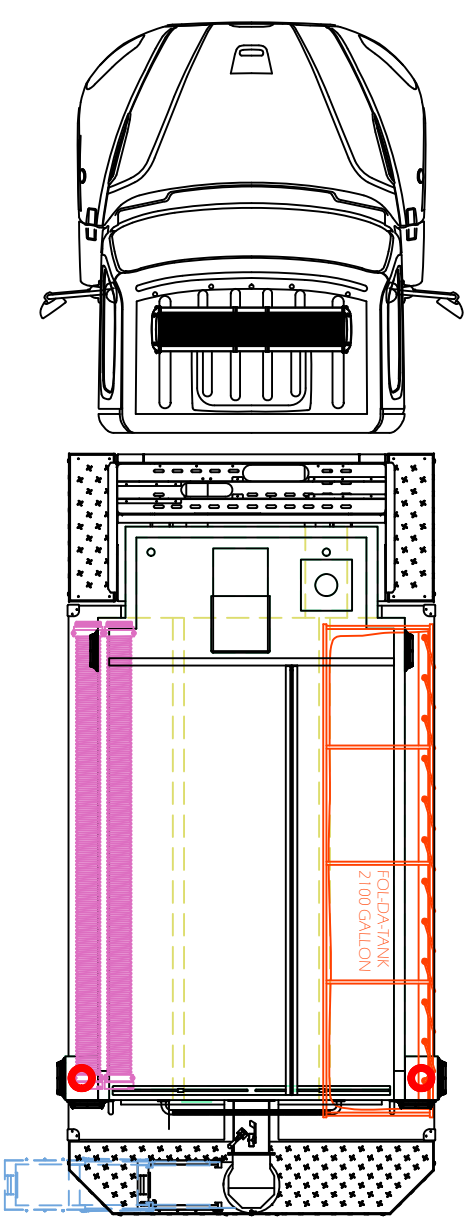
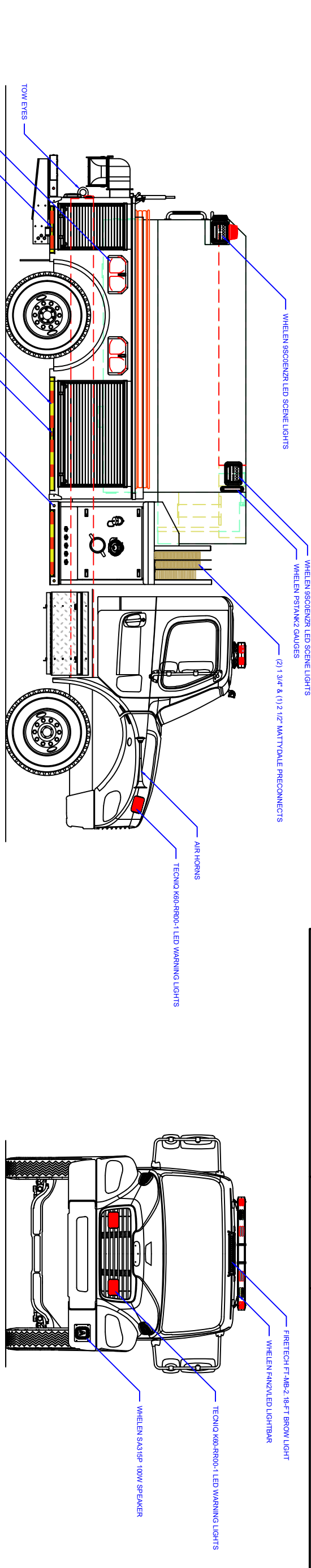

UNLESS OTHERWISE SPECIFIED DIMENSIONS ARE IN INCHES TOLERANCES ARE NOT CUMULATIVE

COMPARTMENT DIMENSIONS

ALEXIS FIRE EQUIPMENT CO.
 P.O. BOX 549, ALEXIS, ILLINOIS 61412

REV	DESCRIPTION	DATE	DWN	PUMP MODEL	PUMP GPM	MATERIAL
01	STANCHIONS & LIGHTS CHANGED	2/18/26	MJT	21250		Stainless Steel

Control Location:	Apparatus Type:
Under Tank	Tanker
Pump Drive: PTO	Chassis: FREIGHTLINER M2 112 2-DR
Pump Make: Waterloo	Tank Capacity: 2000
Pump Model: CXVPA	
Pump GPM: 1250	

COMP #	DOOR OPENING SIZES	DRAWN	DATE	SIZE SCALE	DWG NO	CONTRACT #
L1 & R1	49" WIDE X 27" HIGH X 25" DEEP	M. TINKHAM	11/6/24	1/2" = 1'	T-N45	2875
L2 & R2	19" WIDE X 27" HIGH X 25" DEEP					

ALEXIS FIRE EQUIPMENT
 ALEXIS, IL

TANKER

T-N45

SHEET 1 OF 2



 Alexis Fire Equipment
 109 East Broadway / Alexis, IL 61412
 800-322-2284  sales@alexisfire.com
 AlexisFire.com

Alexis Fire Equipment Company
Alexis, IL

We hereby propose to furnish, after your acceptance, approval, and proper execution of the accompanying contract, the fire apparatus as follows:

One (1) Alexis Demo #2675 2000 Gallon Tanker

As per specifications attached herewith.

TOTAL APPARATUS.....\$ *

* Does not include any applicable taxes. Any local or state tax, if applicable, must be added to the above price.

Shipment of completed apparatus shall be made within 625 calendar days after our approval of properly signed contract, subject to causes beyond our control. This proposal is made subject to your acceptance within thirty (30) days from date of same. If acceptance is delayed beyond that period, we will, upon request, advise you of any increase in said amount which may be occasioned by causes beyond our control.

Respectfully submitted,
ALEXIS FIRE EQUIPMENT COMPANY

By: _____

"QUALITY HAS NO SUBSTITUTE"



 Alexis Fire Equipment
109 East Broadway / Alexis, IL 61412
 800-322-2284  sales@alexisfire.com
 AlexisFire.com

PAYMENT TERMS

The chassis payment shall be made within ten (10) days of invoicing.

The balance of the contract plus any contract alterations shall be payable upon the delivery of the finished unit.

Upon payment, the Alexis Fire Equipment Company shall furnish the purchaser a "Statement of Origin" or the necessary validated documents required for title application.

Additional payment terms available upon request.



 Alexis Fire Equipment
109 East Broadway / Alexis, IL 61412
 800-322-2284  sales@alexisfire.com
 AlexisFire.com

ISO 9001:

Alexis Fire Equipment Company operates a Quality Management System under the requirements of ISO 9001. These standards, sponsored by the "International Organization for Standardization (ISO)," specify the quality systems that shall be established by the manufacturer for design, manufacture, installation and service.



SERVICE CENTER:

The Alexis Priority-One service team is staffed with factory trained mechanics ready to meet your service requirements. Our staff is continually working on maintaining updated EVT and ASE certification.

The Alexis Service Team is available 24 hours a day, 7 days a week for your service emergencies. We use the latest paging system for fast, efficient and reliable service.

Our service facility covers an area of approximately 14,000 square feet.

The Alexis Service Team can assist you in fire apparatus service, ambulance service, aerial device maintenance, generator and rescue tool maintenance and service, and air pack inspections. Our staff can provide our customers with a complete apparatus training program, meeting the latest training requirements.

Alexis is a single source warranty center for the following manufacturers: Spartan Motors, Darley, Hale, and Waterous.

Our service team has over 50 years of cumulative experience in the fire service industry. In addition, they are backed by our fabrication, electrical, and paint and finish departments. This combination of training and hands-on experience offers true reliability and dependability.

Alexis keeps detailed documentation of all repair, maintenance, and inspection performed by our personnel. With time and manpower at such a premium among many fire departments, why not allow the Alexis Service Team to set up and maintain records for your fleet?

The Alexis Service Team is committed to providing prompt and courteous service, quality products and fair pricing.

Business: Alexis Fire Equipment Company
Location: 109 East Broadway Alexis, IL 61412
Phone: 800-322-2284



 Alexis Fire Equipment
109 East Broadway / Alexis, IL 61412
 800-322-2284  sales@alexisfire.com
 AlexisFire.com

DELIVERY:

The finished apparatus shall be picked up by the dealer organization at the plant site of the Alexis Fire Equipment Company in Alexis, Illinois.

To ensure proper break-in of all drive train components while under warranty, the finished apparatus shall be delivered to the purchaser under its own power.

The apparatus shall be covered by comprehensive and liability insurance during the delivery period. The purchaser shall assume the insurance obligation on acceptance, and at that time shall present to the manufacturer's agent a certificate of verification, showing liability, comprehensive and collision insurance coverage.



GENERAL INFORMATION:

LOCATION

The Alexis Fire Equipment facilities are located at 109 East Broadway, Alexis, Illinois 61412. We maintain a complete stock of parts and services available around-the-clock. We also propose to maintain parts and service for a minimum period of twenty (20) years on all apparatus which is manufactured.

NOTATION

To further assure the customer of our ability to manufacture quality fire apparatus, we are proud of the fact that Alexis Fire Equipment Company is family-owned and has been in the fire apparatus business since 1947. All apparatus manufactured by Alexis Fire Equipment are designed and built to meet the requirements of the latest edition of NFPA 1900.

PERSONNEL CAPACITIES

To meet the spirit of N.F.P.A. 1500 paragraph 6.3.1, this apparatus has been designed to transport not more than two (2) people.

6.3 Riding in Fire Apparatus

6.3.1 All persons riding in fire apparatus shall be seated and belted securely to the vehicle by seat belts in approved riding positions and at any time the vehicle is in motion. Standing or riding on tailsteps, sidesteps, running boards or in any other exposed position shall be specifically prohibited.

MAXIMUM TOP SPEED:

To meet the intent of NFPA 1900 7.16.2, the top speed of the vehicle shall not exceed 60 MPH or the manufacturer's maximum fire service speed rating for the tires installed on the apparatus, whichever is lower.

INFORMATION TO BE PROVIDED:

Alexis Fire Equipment Company shall supply, at the time of delivery, the following documents:

- A) The manufacturer's record of apparatus construction details, including the following information:
1. Owner's name and address
 2. Apparatus manufacturer, model, and serial number.
 3. Chassis make, model, and serial number.
 4. GAWR of front and rear axles.
 5. Front tire size and total rated capacity in pounds.
 6. Rear tire size and total rated capacity in pounds.
 7. Chassis weight distribution in pounds with water and manufacturer mounted equipment.
 8. Engine make, model, serial number, number of cylinders, bore, stroke, displacement and compression ratio, rated horsepower and related speed, and no-load governed speed.
 9. Type of fuel and fuel tank capacity.
 10. Electrical system voltage and alternator output in amps.
 11. Battery make and model, capacity in CCA.
 12. Transmission make, model, and type.
 13. Pump to drive through the transmission (yes or no)
 14. Engine to pump gear ratio used
 15. Pump make, model, rated capacity in g.p.m., serial number, number of stages, and impeller diameter in inches.
 16. Pump transmission make, model, and serial number.
 17. Priming device type.
 18. Type of pump pressure control system.
 19. Auxiliary pump make, model, rated capacity in g.p.m., serial number, number of stages, and impeller diameter in inches.
 20. Water tank certified capacity in gallons.
 21. Aerial device type, rated vertical height in feet, rated horizontal reach in feet, and rated capacity in pounds.
 22. Paint numbers
 23. Company name and signature of responsible company executive.
- B) If the apparatus has a fire pump, the pump manufacturer's certification of suction capability.
- C) If the apparatus has a fire pump, a copy of the apparatus manufacturer's approval for stationary pumping applications.
- D) If the apparatus has a fire pump, the engine manufacturer's certified brake horsepower curve for the engine furnished, showing the maximum no-load governed speed.
- E) If the apparatus has a fire pump, the pump manufacturer's certification of hydrostatic test.
- F) If the apparatus has a fire pump, the certification of inspection and test for the fire pump.
- G) If the apparatus has an aerial device, the certification of inspection and test for the aerial device.
- H) If the apparatus has an aerial device, all the technical information required for inspections to comply with NFPA.
- I) Weight documents from a certified scale - showing actual loading on the front axle, rear axle(s), and

overall vehicle (with the water tank full but without personnel, equipment, and hose) - shall be supplied with the completed vehicle.

- J) Written load analysis and results of the electrical system performance tests.
- K) If the apparatus is equipped with a water tank, the certification of water tank capacity.
- L) If the apparatus has a fire pump, two (2) copies of the pump operation and maintenance manual.
- M) Two (2) destination effective wiring diagrams.
- N) Copies of electrical and mechanical component manuals for equipment purchased on or with the apparatus.
- O) A sketch of the booster tank indicating all dimensions and baffle locations.
- P) If the apparatus has a pump, one (1) certification of third party test

WARRANTY:

Alexis Fire Equipment Co., Inc. warrants each new piece of Alexis fire and rescue apparatus to be free from defects in material and workmanship under normal use and service. Our obligation under this warranty is limited to repairing or replacing, as the company may elect, any part or parts thereof which shall be returned to us with transportation charges prepaid, and as to which examination shall disclose to the company's satisfaction to have been defective, provided that such part, or parts shall be returned to us not later than two years after delivery of such vehicle. Such defective part or parts will be repaired or replaced free of charge and without charge for installation to the original purchaser. All water tanks will be warranted as stated herein and may have extended warranty as explained elsewhere in the Alexis Fire Equipment Co. Proposal.

This warranty will not apply:

1. To normal maintenance service or adjustments.
2. To any vehicle which shall have been repaired or altered outside of our factory, in any way so as, in our judgement, to affect its stability, nor which has been subject to misuse, negligence, or accident, nor to any vehicle made by us which shall have been operated at a speed exceeding the factory rated speed, or loaded beyond the factory rated load capacity.
3. To the chassis and associated equipment furnished with chassis, signaling device, generators, batteries or other trade accessories. These are usually warranted separately by their respective manufacturers.
4. To work performed by an outside service without prior authorization obtained from Alexis Fire Equipment.
5. To costs incurred from an outside service for non-warranty related items.



This warranty is in lieu of all other warranties, expressed or implied, and all other representations to the original purchaser and all other obligations or liabilities, including liability for incidental or consequential damages on the part of the company. We neither assume or authorize any other person to give or assume any other warranty or liability o the company’s behalf unless made or assumed in writing by the company.

Surety Bond, if required, will cover standard two-year warranty period only and will not cover any extended warranties allowed by Alexis Fire Equipment co. or other component manufacturers.

LENGTH AND/OR HEIGHT LIMITATIONS:

OVERALL HEIGHT:

There shall be no overall height restrictions.

OVERALL LENGTH:

There shall be no overall length restrictions.

CHASSIS MODIFICATIONS:

MUD FLAPS:

Each rear fender shall be extended with a black rubber mud flap, thus preventing splash and road debris from damaging the apparatus body.

CHASSIS SUPPLIED WHEELS:

The wheel finish on the apparatus shall remain as specified in the chassis specifications.

LABELS:

A permanent plate in the driving compartment shall specify the quantity and type of the following fluids used in the vehicle:

- Engine Oil
- Engine Coolant
- Chassis Transmission Fluid

- Pump Transmission Lubrication Fluid
- Pump Primer Fluid (if applicable)
- Drive Axle(s) Lubrication Fluid
- Air-Conditioning Refrigerant
- Air-Conditioning Lubrication Oil
- Power Steering Fluid
- Cab Tilt Mechanism Fluid
- Transfer Case Fluid
- Equipment Rack Fluid
- CAFS Air Compressor System Lubricant
- Generator System Lubricant
- Front Tire Cold Pressure
- Rear Tire Cold Pressure
- Maximum Tire Speed Ratings

A final manufacturer's certification of the GVWR or GCWR along with a certification of each GAWR, shall be supplied on a label affixed to the vehicle.

A sign that reads "Occupants Must Be Seated and Belted When Apparatus Is in Motion" shall be provided. The sign shall be visible from each seated position.

A label that states the number of personnel the vehicle is designed to carry shall be located in an area visible to the driver.

A sign stating the overall height of the vehicle in feet and inches, the overall length of the vehicle in feet and inches, and the GVWR in tons shall be provided and mounted. The sign shall be visible to the driver of the vehicle while seated.

A label stating "Do Not Wear Helmet While Seated" shall be visible from each seating position.

A label stating "All Equipment Stored in the cab shall be properly secured" shall be visible from each seating position.

A "Do Not Ride" label shall be visible near all stepping and standing surfaces

AIR LIMITER:

A limiter valve shall be installed on the chassis air reserve tank, eliminating the use of all air accessories when the chassis air pressure is under 100 psi, thus reserving all available air for braking effort.



HELMET STORAGE:

To meet the intent of NFPA 11.1.11.2, the helmet for each occupant shall be stored in an exterior compartment.

PUMP AND PIPING:

PTO PUMP:

MANUFACTURER: Waterous.
MODEL: CXVPA 1250

CAPACITY: 1250 gpm. @ 150 psi.
SUCTION SIZE: 6" NST

PUMP SPECIFICATIONS

PUMP

The pump shall be of two piece construction and shall comply with all applicable requirements of the latest standards for automotive fire apparatus of the National Fire Protection Association, NFPA No. 1901, and shall have a rated capacity of 750 - 1500 GPM. The Pump shall be free from objectionable pulsation and vibration under all normal operating conditions.

PUMP BODY

The pump body shall be close-grained, gray iron and can be vertically split in two sections for easy removal of the impeller assembly. Pump body halves shall be bolted together on a single vertical face to minimize leakage and facilitate reassembly.

INTAKE CONNECTION

The intake connection shall be a 6" Victaulic Intake

IMPELLER

The impellers shall be bronze, accurately balanced (mechanically and hydraulically), labyrinth type, wear rings that resist water bypass and loss of efficiency due to wear.

WEAR RINGS

The wear rings shall be bronze and shall be easily replaceable to restore original pump efficiency and eliminate the need for replacing the entire pump casing due to wear.

IMPELLER SHAFT

The impeller shaft shall be heat treated stainless steel, accurately ground to size.

ANTI-FRICTION BEARINGS

The impeller shaft shall be supported at each end by oil or grease lubricated anti-friction ball bearings for rigid and precise support. Bearings shall be protected from water and sediment by suitable seal housings, flinger rings, and oil seals. No sleeve type bearings shall be used.

PUMP SEALS

The pump shall be equipped with self-adjusting, maintenance-free, mechanical shaft seals.

PUMP TRANSMISSION

The pump housing shall be made of an aluminum case. The pump transmission shall be rigidly attached to the pump body assembly and be of latest design incorporating a high strength, involute tooth form chain drive capable of operating at high speeds to provide smooth, quiet transfer of power.

PRIMING PUMP:STOCK ITEM

A Trident Model #31.001.7 air operated priming system shall be installed. The unit shall be of all brass and stainless steel construction and designed for fire pumps of 1,250 GPM (4,600 LPM) or more. Due to corrosion exposure no aluminum or vanes shall be used in the primer design. The primer shall be three-barrel design with ¾" NPT connection to the fire pump.

The primer shall be mounted above the pump impeller so that the priming line will automatically drain back to the pump. The primer shall also automatically drain when the panel control actuator is not in operation. The inlet side of the primer shall include a brass 'wye' type strainer with removable stainless steel fine mesh strainer to prevent entry of debris into the primer body.

Performance, Safety, and NFPA Compliance

The priming system shall be capable to a vertical lift to 22 inches of mercury and shall be fully compliant to applicable NFPA standards for vertical lift. The system shall create vacuum by using air

from the chassis air brake system through a three-barrel multi-stage internal “venturi nozzles” within the primer body. The noise level during operation of the primer shall not exceed 75 Db.

Air Flow Requirements

The primer shall require a minimum of 15.6 cubic foot per minute air compressor and shall be capable of meeting drafting requirements at high idle engine speed. The air supply shall be from a chassis supplied ‘protected’ air storage tank with a pressure protection valve. The air supply line shall have a pressure protection valve set between 70 to 80 PSIG.

Primer Control

The primer control shall have a manually operated, panel mounted “push to prime” air valve; which will direct air pressure from the air brake storage tank to the primer body. To prevent freezing, no water shall flow to and from the panel control.

Power Requirements

To reduce the electrical power requirements on the fire apparatus the priming system shall be air powered. The system shall not require annual tear-down and maintenance, an electric motor or solenoid, electrical wiring, lubrication, belt drive, or clutch assembly.

Warranty

The primer shall be covered by a five (5) year parts warranty.

DRIVELINES:

The PTO pumping system drivelines shall be manufactured by the apparatus manufacturer. The drivelines shall be professionally balanced by the apparatus manufacturer to ensure complete system balance.

6" SUCTION:

One (1) 6" NST suction shall be located on each side of the apparatus body. An inlet screen and a 6" handle cap shall be included.

PIPING:

The piping will be stainless steel material throughout the waterway system. The suction waterway shall

be 6" 304 stainless steel material. The suction waterways shall be designed to flow a minimum of 17% in excess of the rated capacity from draft. The suction piping shall incorporate a 4" suction inlet to allow for full flow from the tank valve assembly. The suction piping shall be adapted from 6" TIPT to NST with a chrome adapter. The suction system shall be designed with 6" victaulic couplings to allow ease of access for maintenance or removal of the pumping system.

The discharge system shall incorporate a 4" stainless steel distribution system. The manifold shall be fed from the 4" piping system. The discharge system shall incorporate a 4" victaulic system to allow ease of access for maintenance or removal of the pumping system. Each discharge shall be fed from above the manifold system.

PUMP DRAINS: ITEM IN STOCK

The entire pump and its controls shall be drainable with a master drain piped to the lowest points of the pump and its control piping. The master drain shall be of a threaded design that will seal all drain points without allowing recycle.

REMOTE PUMP SHIFT:

The PTO driven pump shall be driven from the 10-bolt PTO opening of the automatic transmission through a "Hot-Shift" power take off. The power take off shall be engaged electrically from the cab. Lights shall be positioned at each switch location to indicate PTO engagement.

INTAKE PRESSURE RELIEF VALVE USE STOCK RELIEF VALVE

One (1) TFF SUCTION SIDE relief valve shall be provided. The relief valve is designed to be installed permanently on the suction side of the pump..

The relief valve shall be fully adjustable from 75 to 250 PSI which will be pre-set at 125 PSI. The valve shall be brass construction with a stainless steel mechanism and it shall have a rubber seat to ensure a positive vacuum seal.

The relief valve shall be set at 125 PSI

REQUIRED PUMP TESTING:

If the fire pump has a rated capacity of 750 gpm or greater capacity, the pump shall be tested after the pump and all its associated piping and equipment have been installed on the apparatus. The tests shall be conducted at the Alexis facility and certified by an EVT Certified pump operator. The certification

shall include (at least) the following tests: the pumping test, the pumping engine overload test, the pressure control system test, the priming device tests, and the vacuum test. If the apparatus is equipped with a water tank, the water tank to pump flow test shall be included.

A test plate shall be provided at the pump operator's position that gives the following information: the rated discharges and pressures, the speed of the engine determined by the certification test for each unit, the position of the parallel/series pump as used, and the no-load governed speed of the engine stated by the engine manufacturer on a certified brake horsepower curve. The plate shall be completely stamped with all information at the factory and attached to the vehicle prior to shipping.

PUMP CERTIFICATION:

Upon final apparatus delivery, the original copy of the certificate of inspection by an independent third party shall be furnished.

The pumping system shall be capable of delivering:

- 100 % of rated capacity at 150 psi. net pump pressure
- 70 % of rated capacity at 200 psi. net pump pressure
- 50 % of rated capacity at 250 psi. net pump pressure

INTERMEDIATE PUMP MODULE:

A free standing pump module shall be located between the chassis cab and the tank of the apparatus. The tank shall project over the module assembly for better weight distribution and handling. The pump module shall be no wider than 40" to provide an optimal turning radius for the unit.

The pump module shall be a self-supported structure mounted to the frame separate from the cab and body. Pump module design beginning with a cage framework assemblies that are precision manufactured from corrosion free heavy 7 gauge stainless steel forms. This framework mounts to the truck frame through a mounting design complemented with four (4) VIBRA mount elastomer cushions. The result shall be a mounting system that allows for the twisting movement of the truck frame without undue stress loading of the pump module.

The pump operator's panel shall be located on the left side of the apparatus, and the suction/discharge panels shall be located on the left and right sides of the apparatus.

An automotive rubber seal shall be adhered to the pump panel to reduce vibration that may occur during pump operation or road application. The panel shall be attached to the framing with 3/16" pin, 1" knuckle, continuous stainless steel hinges. The hinges shall be attached with stainless steel fasteners.

Each panel shall be secured with latches at the top and bottom of the door opening.

The top left operator's panel shall be hinged for access to the individual gauges and the electrical components. No exceptions.

Once the module is designed, the valve control placements on a control module shall result in a neat and orderly layout. Open the access door on a side control module and peer inside. The horizontal control rods appear neat and orderly.

PUMP CONTROLS:

The pump panel shall incorporate push pull controls for each discharge, the tank fill recycle, and the tank to pump valve (if applicable.)

The control handles shall be placed on an even plane with the upper control panel.

PUMP OPERATOR'S PANEL:

The pump operator's panel shall include the following:

PRESSURE GOVERNOR and MONITORING DISPLAY STOCK GOVERNOR

One (1) Fire Research PumpBoss PBA401-D00 pressure governor and control module kit shall be installed. The kit shall include a control module, intake pressure sensor, discharge pressure sensor, and cables. The control module housing shall be waterproof and have dimensions not to exceed 7 1/2" high by 3 5/8" wide. The control knob shall be 2" in diameter with no mechanical stops, have a serrated grip, and a red idle push button in the center. It shall not extend more than 2" from the front of the control module. The control LCD shall be 3.5" in size with a minimum brightness of 1000 nits and optically bonded to 3mm Borofloat Glass. Inputs for monitored engine information shall be from a J1939 data bus or independent sensors. Outputs for engine control shall be on the J1939 data bus. Inputs from the pump discharge and intake pressure sensors shall be electrical.

The following continuous displays shall be provided:

- Engine RPM; shown on LCD screen
- Check engine and stop engine warning; shown on LCD screen
- Engine oil pressure; shown on LCD screen
- Engine coolant temperature; shown on LCD screen
- Transmission Temperature; shown on LCD screen
- Battery voltage; shown on LCD screen
- Pressure and RPM operating mode LEDs

Pressure / RPM setting; shown on LCD screen

Throttle ready / Ok to Pump LEDs.

On screen (LCD) message display shall show diagnostic and warning messages as they occur. It shall show monitored apparatus information, stored data, and program options when selected by the operator. LCD Screen and LED's intensity shall be automatically adjusted for day and nighttime operation.

The program shall store the accumulated operating hours for the pump and engine to be displayed with the push of a button. It shall monitor inputs and support audible and visual warning alarms for the following conditions:

- High Battery Voltage
- Low Battery Voltage (Engine Off)
- Low Battery Voltage (Engine Running)
- High Transmission Temperature
- Low Engine Oil Pressure
- High Engine Coolant Temperature
- Out of Water (visual alarm only)
- No Engine Response (visual alarm only).

The program features shall be accessed via push buttons located on the front of the control module. There shall be a USB port located at the rear of the control module to upload future firmware enhancements.

The pressure governor shall operate in two control modes, pressure and RPM. No discharge pressure or engine RPM variation shall occur when switching between modes. A throttle ready and Ok to Pump LED shall light when the interlock signal is recognized. The pressure governor shall start in pressure mode and set the engine RPM to idle. In pressure mode the pressure governor shall automatically regulate the discharge pressure at the level set by the operator. In RPM mode the governor shall maintain the engine RPM at the level set by the operator except in the event of a discharge pressure increase. The pressure governor shall limit a discharge pressure increase in RPM mode to a maximum of 30 psi. Other safety features shall include recognition of low water and no water conditions with an automatic programmed response and a push button to return the engine to idle.

The pressure governor control module shall be programmed at installation for a Cummins engine.

MASTER GAUGES:

One (1) 4½" compound gauge with a range of 30-0-400 PSI.

One (1) 4½" pressure gauge with a range of 0-400 PSI

The compound and pressure gauges shall remain unlit as previously specified.



WHELEN TANK LEVEL INDICATOR:

WHELEN PS TANK 2 tank remote indicator shall be installed. The indicator shall show the volume of water in the tank on to see super bright Tri-color LEDs. The indicator case shall be waterproof, manufactured of Polycarbonate material with an integrated lens. The package includes a rubber gasket.

The remote indicator shall receive input information over a datalink from a Fire Research TankVision primary indicator model WLA300-A00. The remote indicator shall indicate the level as a single color in Red for 25% or less, Amber color for up to 50% volume, Blue color for up to 75% volume and Green color for up to 100% volume. When the level reaches 25%, the red LEDs will begin flashing. When the level is empty, the red LEDs will scroll in a down-chasing motion and then flash three times. It shall have the program capability to adjust the brightness level for day time and nighttime viewing.

There shall be three (3) Tank Level strip lights provided on the apparatus, one (1) each side and one (1) at the rear.

In addition to the LED water level gauge will be located on the pump operator's panel.

MOUNT THE SIDE STRIP LIGHTS ON THE UPPER PART OF THE BOOSTER TANK

Each strip light shall be mounted utilizing a chrome plated flange.

COLOR CODED TAGS:

Color coded tags with chrome plated bezels shall be provided. Unless otherwise specified all tags shall be color coded to NFPA recommendations and shall be located at the control location, intake/discharge location, and at the drain port location.

A FAMA 25 label stating "Trained Personnel Only" shall be provided on the pump operator's panel.

Alexis Standard Tags:

Front Bumper Jump Line	Orange
Preconnect #1	Red
Preconnect #2	Yellow
Preconnect #3	Seafoam
Discharge #1	White
Discharge #2	Blue
Discharge #3	Black
Discharge #4	Green

Discharge #5/Water tower
Deluge/deck gun
Large-diameter hose
Foam line(s)
Booster reel(s)
Inlets

Purple
Silver
Yellow with white border
Red with white border
Gray
Burgundy

TEST PORTS:

Vacuum and pressure test ports shall be provided on the pump operator's panel for connection of the pump test gauges.

PUSH BUTTON ON PUMP PANEL FOR AIR HORNS:

There shall be a push button provided on the pump panel to activate the air horns.

RUNNING BOARDS

The running boards shall be constructed of 12 gauge star punched stainless steel material. The material meets NFPA standard 12.6.4.1: all exterior surfaces have a minimum slip resistance of .68.

RUB RAILS - RUNNING BOARDS:

Bolt on aluminum rub rails shall be installed one (1) each side on the running boards. Said rub rails will be fabricated of a polished "C" channel aluminum, mounted to the running board utilizing ¼" plastic spacers.

The rub rails shall incorporate the LED ground lights and LED lower warning lights. Each light strip shall run the full length of each rub rail.

The channel designed rub rail shall incorporate a highly reflective red and fluorescent yellow green reflective stripe to aid in apparatus protection.

STAINLESS STEEL PUMP MODULE:

The area above the side discharge panels on each side shall be manufactured of 14 gauge brushed stainless steel material.

STAINLESS STEEL PUMP PANELS:

The pump operator's panel and discharge panels shall be manufactured of 12-gauge stainless steel and shall include a full width light hood with one (1) E45 Series LED light strip

The side discharge panel on the passenger side of the apparatus shall be manufactured of 12-gauge stainless steel and shall include a full width light hood with one (1) E45 Series LED light strip

The lights shall be activated by a switch located on the pump operator's panel.

2 ½" DISCHARGE PIPING:

Two (2) 2 ½" discharge(s) shall be located on the left side of the apparatus. Each discharge valve shall be located behind the body panel and controlled from the side control pump operator's panel. Each discharge shall include a self-locking 2½" quarter-turn ball valve, a 2½" chrome cap with chain, and a sweep elbow of at least 30 degrees downward.

Each above valve shall be manually controlled.

One (1) IC line reading gauge supplied for each above discharge. The gauge shall have a 2½ diameter face with a graduated output scale of 0-400 PSI with black print on a bright white background.

2 ½" DISCHARGE PIPING:

One (1) 2 ½" discharge(s) shall be located on the right side of the apparatus. Each discharge valve shall be located behind the body panel and shall be controlled from the side control pump operator's panel. Each shall include a self-locking 2½" quarter-turn ball valve, a 2½" chrome cap with chain, and a sweep elbow of at least 30 degrees downward.

Each above valve shall be manually controlled.

One (1) IC line reading gauge supplied for each above discharge. The gauge shall have a 2½ diameter face with a graduated output scale of 0-400 PSI with black print on a bright white background.

3" DISCHARGE(S), APPARATUS RIGHT SIDE:

One (1) 3" discharge(s) shall be located on the right side of the apparatus with each valve behind the body panel. Each discharge shall be controlled from the side control pump operator's panel. The valve shall be a 3" slow close valve per NFPA.

DISCHARGE ADAPTER:

The 3" discharge shall incorporate one (1) 3" NST LHF x 5" Storz 30 degree elbow with blind cap.

Each above valve shall be manually controlled.

One (1) IC line reading gauge supplied for each above discharge. The gauge shall have a 2½ diameter face with a graduated output scale of 0-400 PSI with black print on a bright white background.

TANK TO PUMP LINE:

One (1) 3" tank to pump line shall be installed into the tank to the suction side of the pump. It shall have 4" piping and valved with a 3" full flow valve. Each valve shall be an air operated valve controlled from the pump operator's panel with a Williams Controls air shift. Each tank line shall incorporate a check valve in the line to meet NFPA 1900.

LINE DRAINS FOR DISCHARGES:

The drain valves shall be Innovative Controls ¾" ball brass drain valves with chrome-plated lift lever handles and ergonomic grips. Each lift handle grip shall feature built-in color-coding labels and a verbiage tag identifying each valve, also supplied by Innovative Controls. The color labels shall also include valve open and close verbiage.

VENTED DISCHARGE CAPS:

Each discharge shall incorporate a vented cap designed to relieve stored pressure in the line when disconnected.

GATED SUCTION, LEFT SIDE:

One (1) 2½" gated suction shall be located on the left side of the apparatus. It shall be piped 2½" i.d. including a 2½" Akron full flow quarter turn valve and a 2½" NST female swivel with plug and chain. It shall be remote controlled from the suction location.

Each above valve shall be manually controlled.

MATTYDALE PRECONNECT MODULE - (2) 1½" AND (1) 2½":

One (1) independent preconnect module shall be located directly behind the chassis cab, above the pump. The module shall be manufactured of stainless steel material, self supported, and shall incorporate three (3) deep cut single lay preconnect hose beds. The Mattydale preconnect shall be designed to allow the extension of hose to the left or right side of the apparatus body.

Two (2) 1½" preconnects shall be provided in the module. The preconnect shall incorporate a 1½", 180° swivel adapted to 1½" fire hose thread. The waterway shall be 2" i.d. and include a 2" full flow quarter turn ball valve that is controlled from the operator's panel. The 1½" preconnect shall have the capacity to contain a minimum of 200 ft. of 1¾" hose with nozzle.

One (1) 2½" preconnect shall be provided in the module. The preconnect shall incorporate a 2½", swivel adapted to 2½" fire hose thread. The waterway shall be 3" i.d. and include a 2½" full flow quarter turn ball valve that is controlled from the operator's panel. The 2½" preconnect shall have the capacity to contain a minimum of 150 ft. of 2½" hose.

Each above valve shall be manually controlled.

One (1) IC line reading gauge supplied for each above discharge. The gauge shall have a 2½" diameter face with a graduated output scale of 0-400 PSI with black print on a bright white background.

MATTYDALE PRECONNECT COVER - HYPALON:

The Mattydale preconnect area shall be covered with a fire and chemical resistant material. It is to be retained to the apparatus with a shock cord and nylon clip system.

The hypalon cover shall be red in color.

TANK FILL RECYCLE:

One (1) 2" waterway shall be incorporated from the pressure side of the pump to the tank. The line shall be controlled from the pump panel and valved with a 2" ball valve to allow a pump cooling recycle or tank fill when pumping from draft. When fully opened, it shall have the capacity to refill the tank at 750 gpm when pumping at 100 psi.

Each above valve shall be manually controlled.

VALVING:

Each and every apparatus valve must be a Stainless Steel Ball Valve, per the following specifications.

The valve shall have an all brass body with flow optimizing stainless steel ball and dual polymer seats. The valve shall be capable of bi-directional flow and incorporate a self-locking ball. The valve shall not require lubrication of seats or any other internal waterway components, and must be capable of swinging out of the waterway for maintenance. The valve shall be manufactured in the United States and shall



carry a ten year warranty.

PIPING:

All waterways described herein shall be of schedule 40 threaded stainless steel pipe, schedule 10 welded stainless steel, or "aeroquip" hose. Each shall be installed with the proper couplings to allow apparatus twisting, flexing, and complete removal for service or replacement.

PLUMBING WARRANTY:

The stainless steel plumbing components and ancillary brass fittings used in the construction of the water/foam plumbing system shall be warranted for a period of ten (10) years or 100,000 miles. This covers structural failures caused by defective design or workmanship, or perforation caused by corrosion, provided the apparatus is used in a normal and reasonable manner. This warranty is extended only to the original purchaser for a period of ten (10) years or 100,000 miles from the date of delivery.

PIPING CERTIFICATION:

Upon final apparatus delivery, a certification sheet shall accompany the unit stating that all piping and the pump have been hydrostatically tested to 250 psi.

BODY:

BODY WARRANTY:

Alexis Fire Equipment Company hereby extends its standard two-year fire and rescue apparatus warranty to include defects in materials and workmanship of the body as well as structural defects which, in the sole opinion of the company, substantially affect the total integrity of the body. This warranty is extended only to the original user-purchaser.

Alexis Fire Equipment warrants the 12 gauge stainless steel bodies, fabricated by Alexis Fire Equipment, under normal use and with reasonable maintenance, shall remain structurally sound for the lifetime of the apparatus per NFPA recommendations or 100,000 miles as long as the design of the apparatus complies with Alexis engineering practices.

The Company reserves the right to require any such repairs to be made either at Alexis Fire Equipment Company, Inc. or another approved service facility, at the option of Alexis Fire Equipment. Transportation cost to and from the servicing location is the responsibility of the user-purchaser.

The warranty shall be null and void if, upon inspection by the Company, the alleged defect is determined to have been caused by abuse, modification, accident, neglect, or lack of proper maintenance.

This warranty does not apply to the following items that are covered by a separate warranty: paint finish, hardware, door assemblies, moldings, and other accessories attached to the body. In addition, this warranty does not apply to any part or accessory manufactured by others and attached to the body.

Alexis Fire Equipment will be given a reasonable opportunity to investigate all claims. The purchaser must commence any action arising out of, based upon or relating to agreement or the breach hereof, within twelve (12) months from the date the cause of the action occurred.

Alexis Fire Equipment makes no other warranty, expressed or implied, with respect to the apparatus body and all implied warranties of merchantability and fitness for a particular purpose are hereby disclaimed.

BODY SUB FRAME – STAINLESS STEEL:

The body sub frame system shall be designed for the emergency service application. The sub frame shall be independent of the chassis frame and is to be constructed of heavy structural material to provide the maximum strength and body support necessary for units utilized in emergency service. The system not only is used for total support designed to carry the total load of the apparatus; the system also allows the unit to be a complete lift off transferable apparatus once completed.

The system is designed to carry the emergency apparatus on the chassis main frame in a European style method. This method allows the apparatus body to float independently from the chassis frame ahead of the rear wheels and shall be rigidly attached behind the rear axle area.

The sub frame system shall be isolated from the chassis frame with a custom full length rubber extrusion that totally locks onto each chassis frame rail. This system isolates the body from the frame while also acting as a cushion between the two units.

The sub frame system shall be manufactured completely of 304 stainless steel material. The stainless steel sub frame shall incorporate 1 x 3 flat 304 stainless steel which shall run the full length of each chassis frame rail from the back of the cab to the end of the frame.

K-Bracing shall be incorporated into the system for strength and compartment support. Each K-Brace shall consist of a 3 x 3 x 7 gauge 304 stainless steel tubing to continue the total sub frame support.

The tank cradle shall be incorporated within the sub frame system to allow for a lower vertical center of gravity and to allow the water load weight to be supported by the sub frame system. The tank cradle shall incorporate the heavy sub frame and 7 gauge 304 stainless steel channel placed in accordance with the poly tank manufacturer's recommendations. Each channel is covered with a custom extruded rubber channel to prevent the water tank from chaffing with the stainless steel sub frame.

It is important to note all welds on the sub frame system shall be welded in methods that are sanctioned by ASME and SAE standards as to allow complete structural integrity as stipulated and shall also follow the guidelines set forth by the Alexis Standards.

APPARATUS REAR PANEL:

The vertical surfaces at the rear, from the tailstep walkway to the top of the body, shall be manufactured of 14 gauge smooth stainless steel, in preparation for Chevron striping.

The rear of the tank shall remain poly material painted to match the body.

WHEEL HOUSING, STAINLESS STEEL (PAINTED):

The rear wheel housing shall be constructed of 304 PAINTED stainless steel and shall incorporate a polished stainless steel fenderette. The circular interliner shall be manufactured of 3/16" Tivar 1000 polymer material.

The polymer material is a chemical and corrosion resistant material, thereby preventing excess wear and corrosion from occurring due to wintertime road chemicals. The polymer material shall be held in place by the use of polymer retainers or bolts for ease of repair and access to the wheel well area.

TAIL STEP:

The tail step shall be constructed of 12 gauge star punched stainless steel material. The material meets NFPA standard 12.6.4.1: all exterior surfaces have a minimum slip resistance of .68.

The tail step shall incorporate 45° tapered corners.

The tail step shall be 20" deep

REAR TOW EYES:

Two (2) 3/4" thick steel tow eyes shall be securely fastened to the rear frame rails, one (1) each side. Each tow eye shall extend through the rear body panel



DUAL BOTTLE AIR BOTTLE COMPARTMENT(S):

One (1) Model 101400-1X air bottle storage compartment(s) shall be located in the apparatus wheel well assemblies. For ease of access, each bottle shall be stored within an individual storage tube manufactured of poly material. Each individual storage tube shall be designed in a tear drop profile with flex-tube configuration for optimal abrasion-less storage.

The compartment shall incorporate a double bottle horizontally hinged drop down stainless steel door with a black push button latch. A rubber bumper shall be provided to protect the wheel well finish. Each compartment shall have the capacity to carry two (2) air bottles.

LOCATION: Left Side Ahead of the Rear Wheels

DUAL BOTTLE AIR BOTTLE COMPARTMENT(S):

One (1) Model 101400-1X air bottle storage compartment(s) shall be located in the apparatus wheel well assemblies. For ease of access, each bottle shall be stored within an individual storage tube manufactured of poly material. Each individual storage tube shall be designed in a tear drop profile with flex-tube configuration for optimal abrasion-less storage.

The compartment shall incorporate a double bottle horizontally hinged drop down stainless steel door with a black push button latch. A rubber bumper shall be provided to protect the wheel well finish. Each compartment shall have the capacity to carry two (2) air bottles.

LOCATION: Left Side Behind the Rear Wheels

DUAL BOTTLE AIR BOTTLE COMPARTMENT(S):

One (1) Model 101400-1X air bottle storage compartment(s) shall be located in the apparatus wheel well assemblies. For ease of access, each bottle shall be stored within an individual storage tube manufactured of poly material. Each individual storage tube shall be designed in a tear drop profile with flex-tube configuration for optimal abrasion-less storage.

The compartment shall incorporate a double bottle horizontally hinged drop down stainless steel door with a black push button latch. A rubber bumper shall be provided to protect the wheel well finish. Each compartment shall have the capacity to carry two (2) air bottles.

LOCATION: Right Side Ahead of the Rear Wheels

DUAL BOTTLE AIR BOTTLE COMPARTMENT(S):

One (1) Model 101400-1X air bottle storage compartment(s) shall be located in the apparatus wheel well assemblies. For ease of access, each bottle shall be stored within an individual storage tube manufactured of poly material. Each individual storage tube shall be designed in a tear drop profile with flex-tube configuration for optimal abrasion-less storage.

The compartment shall incorporate a double bottle horizontally hinged drop down stainless steel door with a black push button latch. A rubber bumper shall be provided to protect the wheel well finish. Each compartment shall have the capacity to carry two (2) air bottles.

LOCATION: Right Side Behind the Rear Wheels

COMPARTMENTATION:

COMPARTMENT DESIGN:

The compartmentation shall be fabricated of bolted 14 gauge 304 stainless steel walls and 12 gauge 304 stainless steel floors. The compartmentation is designed to be an intricate part of the body and subframe for maximum compartment support. The compartment tops shall be fabricated of smooth stainless steel material and shall meet the intent of the latest edition of NFPA 12.6 regarding stepping, standing, and walking surfaces. The material shall be formed over each compartment top to act as drip protection over each compartment opening. The compartment flooring will be sweep out design.

The specified lighting in each compartment shall be switched automatically with the doors. The lighting shall meet the requirements of NFPA 10.9.5

NON-PAINTED ROLL-UP DOORS: IN STOCK

The compartments shall have ROM Series IV Roll-up Shutter Doors with a satin finish. The doors shall be made of an anodized aluminum slat incorporating an exclusive seal that prohibits water intrusion, absorbs shock, eliminates clatter, and provides quiet, vibration-free performance. The lift bar shall be a D-shaped bar for strength and ease of use.

TALL BOTTOM RAIL:

Each ROM door shall incorporate a tall bottom rail for improved accessibility.

LEFT SIDE BODY SHALL BE AS FOLLOWS:

L1

A roll-up door compartment assembly with a door opening of 49" wide x 27" high x 25" deep shall be incorporated on the apparatus left side ahead of the rear wheels.

The compartment shall include the following:

Unistrut Tracking

ROM DuroStrip V5 LED strip lighting to illuminate the entire area. The lights shall run the entire height of the compartment on each side of the door opening.

L2

A roll-up door compartment assembly with a door opening of 19" wide x 27" high x 25" deep shall be incorporated on the apparatus left side behind the rear wheels.

The compartment shall include the following:

Unistrut Tracking

ROM DuroStrip V5 LED strip lighting to illuminate the entire area. The lights shall run the entire height of the compartment on each side of the door opening.

RIGHT SIDE BODY SHALL BE AS FOLLOWS:

R1

A roll-up door compartment assembly with a door opening of 49" wide x 27" high x 25" deep shall be incorporated on the apparatus right side ahead of the rear wheels.

The compartment shall include the following:

Unistrut Tracking

ROM DuroStrip V5 LED strip lighting to illuminate the entire area. The lights shall run the entire height of the compartment on each side of the door opening.

R2



A roll-up door compartment assembly with a door opening of 19" wide x 27" high x 25" deep shall be incorporated on the apparatus right side behind the rear wheels.

The compartment shall include the following:

Unistrut Tracking

ROM DuroStrip V5 LED strip lighting to illuminate the entire area. The lights shall run the entire height of the compartment on each side of the door opening.

FOL-DA-TANK STORAGE:

One (1) fol-da-tank storage area shall be provided on the top of the compartment on the specified side. The fol-da-tank shall lie between the top of the compartments and the bottom of the "T" cutout of the tank. The storage area will have an open top. Velcro straps shall be provided to retain the Fol-Da-Tank.

The tank storage area shall have a stop at the front and rear and shall be open on the sides.

Each bracket shall have the capacity for a 2100 gallon fol-da-tank.

LOCATION: Right Side

SUCTION HOSE STORAGE:

One (1) suction hose storage area shall be located on the specified side of the apparatus between the top of the compartment and the bottom of the "T" cutout of the tank. The suction hose storage will have an open top. The suction hose storage area shall have the capacity to carry two (2) 10' lengths of hard suction hose. Velcro straps shall be provided to retain the suction hose.

The suction hose storage area shall have a stop at the front and rear and shall be open on the sides.

LOCATION: Left Side

RUB RAILS:

Bolt on aluminum rub rails shall be installed, below the compartment doors. Said rub rails will be fabricated of a polished "C" channel aluminum, mounted to the body surface utilizing ¼" plastic spacers.

The rub rails shall incorporate the LED ground lights and LED lower warning lights. Each light strip shall run the full length of each rub rail.

The channel designed rub rail shall incorporate a highly reflective red and fluorescent yellow green reflective stripe to aid in apparatus protection.

DURATILE TILE ON FLOOR:

The floor of each main body compartment shall be covered with black Duratile Tile.

VERTICAL UNISTRUT IN COMPARTMENT:

The unistrut tracking as previously specified shall be vertically installed on the compartment walls for use with adjustable shelving. The tracking will allow the shelving to be adjustable to height with an eight (8) bolt lock. The tracking shall be installed from the floor of the compartment to approximately 4" below the ceiling of the compartment, allowing full height adjustability.

TANK:

WET SIDE WATER TANK:

The tank shall have a minimum capacity of 2000 US gallons complete with a lifetime warranty. The tank shall be of a specified configuration, and so designed to be completely independent of the compartment and/or fender modules. When placed on the chassis, the tank shall meet or exceed all federal DOT regulations regarding weight distribution, axle loading, and horizontal and vertical center of gravity locations.

TANK CONSTRUCTION:

The tank shall be constructed using a virgin polypropylene sheet with a minimum thickness of 3/4". This material shall be a high impact co-polymer (HIC), non-corrosive stress relieved thermo-plastic and U.V. stabilized for maximum protection.

This material shall be referred to in the rest of this specification as "HIC polypropylene".

All joints and seams shall be nitrogen welded and tested for maximum strength and integrity. All swash partitions shall interlock and be welded to each other as well as to the walls of the tank.

Care will be taken not to scratch the outer shell of the tank as the tank sides will be partially exposed in the finished product. All exposed corners shall be finish routed to eliminate sharp corners and to give

the tank a neat appearance.

The tank shall incorporate two mounting blocks welded into the floor. These blocks will be designed to restrain the tank in the sub-frame. See the "Tank Sub-frame" section of this specification.

OUTLETS:

There will be a minimum of three (3) tank connections: one for the tank to pump suction line which will be a minimum 3" NPT coupling piped to the sump; one for a tank clean-out/drain which shall be a minimum 3" NPT coupling in the sump floor; and, one for a tank fill line which will be a minimum 2" NPT coupling. All tank fill couplings will be backed with flow deflectors to break up the stream of water entering the tank. All auxiliary outlets and inlets must meet the current NFPA recommended guidelines in effect at the time of manufacture.

SUMP:

There will be one (1) sump included with the tank which shall incorporate an anti-swirl device. The sump shall be constructed of HIC polypropylene and be located in the left front quarter of the tank.

OVERHANG:

The tank shall incorporate an overhang over the pump. The overhang area shall be adequately supported per the tank manufacturer's recommendations.

MOUNTING:

A sub-frame weldment shall be provided to adequately support the tank, compartments and fender modules in their fully loaded and equipped condition. This sub-frame shall be constructed of the same material as the main body subframe. The design shall allow for proper interface between all body and fender modules as well as ample clearances for the tank. The design shall also consider cross member spacing as it relates to unsupported area under the tank, which shall not exceed 530 square inches. On tanks over 40" in height, an unsupported area of not more than 400 square inches must be maintained. All tanks shall be isolated from the cross member with a minimum of 1/4" thick 60 durometer rubber strips. Although the tank is designed on the free-floating principle, the sub-frame must incorporate provisions for capturing the tank both front and rear as well as side-to-side to prevent shifting during vehicle operation. This shall be accomplished through the use of preformed stainless steel retainer brackets, one on each end of the tank bottom. These brackets shall encapsulate a cross member support as part of the sub-frame. The completed sub-frame shall be attached to the truck frame rails using a hard non-metallic isolator between the frame rail and the sub-frame. Final clamping shall be accomplished through the use of heat treated U-bolts.



PLUMBING PROVISIONS:

The tank shall include two (2) 4" plates at the rear to accommodate tank fills. The tank shall also include one (1) 6" vertical sleeve at the front to accommodate deck gun piping.

FILL TOWER AND COVER:

The tank will have a manual fill tower with a 6" combination vent/overflow pipe. The fill tower will be constructed of HIC polypropylene and shall be large enough to provide filling by means of a conventional 2½" hose nozzle. The tower will be located at the front of the tank and will incorporate an anti-surge provision to minimize water surge during vehicle operation. A full width bulkhead will be provided to separate the fill tower from the balance of the hose bed. The tower will have a removable polypropylene screen and a polypropylene hinged type cover. The vent/overflow pipe shall run through the tank, and exit through the floor of the tank behind the rear axle to maximize traction.

The tank cover shall be constructed of HIC polypropylene with a minimum thickness of ½". It shall be of a flush bi-directional locking, design which allows for individual removal and inspection if necessary. Each one of the covers will have hold-downs which extend through the covers and will assist in keeping the covers rigid under fast filling conditions. An adequate lifting provision shall be provided which is capable of suspending the empty water tank with a safety factor of at least 2:1. The lifting dowel thread configuration must withstand a torque input of 80 ft/lbs.

HOSEBED:

There shall be a hosebed area constructed of HIC polypropylene on top of the tank consisting of two side walls and one front panel. This hosebed shall be welded to the outside perimeter of the tank cover. Drain holes shall be provided at the forward end of the hosebed in each corner.

The hose bed side walls shall be tapered at the rear to provide a pleasing appearance and provide better clearance for the fire station doors.

HOSEBED FLOOR:

The floor of the hosebed shall incorporate a channel system for improved air flow and to aid in the drainage of accumulated moisture on the floor, NO EXCEPTIONS.

LIGHT BOXES:

The side wall of the hosebed on each side shall incorporate light boxes for mounting of rear upper

warning lights and rear/side scene lights. The light boxes shall be built-in, manufactured of the same material as the hosebed and tank, and paint to match the apparatus body, NO EXCEPTIONS.

The light box on each side shall be lowered from the top of the hosebed to provide a lower profile.

HOSE BED CAPACITY:

The hose bed shall have the capacity to carry the following hose from left to right:

HOSE BED DIVIDER:

One (1) divider shall be located in the hose bed. It shall be constructed of 3/16" aluminum plate. The divider shall be designed for future adjustability with locking blocks in aluminum channels at the front and the rear of the hose bed.

Each hose bed divider shall incorporate hand hold cutouts to assist in accessing the hose bed.

HOSE BED COVER:

One (1) custom tailored hypalon hose bed cover shall be included with the apparatus body. It shall be manufactured of a flame retardant material with a grab tensile of 480 x 500 lbs. and a tongue tear of 160 x 150 lbs. It shall be crack resistant to -40° Fahrenheit and have an adhesion lbs./in of 10.0 lbs. The hose bed cover shall be fitted to the hose bed and retained with a double woven shock cord on the front and both sides. The shock cord shall system shall utilize nylon hooks spaced every 10"-12". The cover shall be sand weighted across the rear flap and shall also include two (2) 2" wide nylon straps with teflon buckle to meet NFPA requirements.

The hose bed cover shall include a 3 year warranty.

The hypalon cover shall be red in color.

The wetside tank shall be painted to match the apparatus body. All tank imperfections shall be addressed and repaired prior to paint, including all corners and joints.

TANK FILL - 4":

One (1) 4" tank fill shall be located at the rear of the apparatus. The assembly shall include a FirePrograms 4" Stainless Steel Fill Valve, Model 500175, four-inch inside diameter internal check valve with appropriately sized hose connection. The assembly shall also include a 3/4" quarter turn line drain.



The FirePrograms 4” Fill Valve is an internally mounted check-type fill valve, capable of flowing at a rate up to 1,000 GPM. The Fill Valve is available in a 4” Victaulic connection or 4” male NPT pipe thread connection for ease of installation. The Fill Valve is self-deflecting, requiring no additional diffusion device. The Fill Valve is constructed of 100% stainless steel avoiding the use of dissimilar metals. The spring actuated piston-type sealing mechanism minimizes seal wear and provides positive sealing of the valve after shutting off the valve at the feed source. The device is designed to be self-cleaning utilizing a replaceable EPDM rubber gasket. Less than 6psi is required to open the valve.

Utilizing two stainless steel internal tank mounting plates, the 4-bolt Fill Valve mechanism is attached directly through the tank wall. The valve design is suitable for simple retrofit installation into existing water tanks.

The 4" fill shall terminate with a 4" NST LHF x 5" Storz 30° elbow with blind cap.

LOCATION: Rear Left Side

TANK DUMP: IN STOCK DUMP / CHECK STOCK

One (1) 10" x 10" square Newton stainless steel swivel dump Model 6012SW-34 with a flip up gate valve shall be installed. It shall include an over center safety lock. The valve shall be bolted to the tank with stainless steel bolts.

The dump shall incorporate a swivel allowing 180° rotation from left to right.

The dump shall be manually controlled from the dump location.

DUMP EXTENSION:

One (1) Newton 36" manually controlled stainless steel extension, model 4036-34, shall be installed on each dump.

The dump shall be located at the rear of the apparatus.

12 VOLT ELECTRICAL:

ELECTRICAL WARRANTY:

Alexis Fire Equipment Co., Inc. warrants each new piece of Alexis fire and rescue apparatus to be free from defects in material and workmanship under normal use and service. Our obligation under this

warranty is limited to repairing or replacing, as the company may elect, any part or parts thereof which shall be returned to us with transportation charges prepaid, and as to which examination shall disclose to the company's satisfaction to have been defective, provided that such part, or parts shall be returned to us within seven (7) years or 50,000 miles after delivery of such vehicle. Such defective part or parts will be repaired or replaced free of charge and without charge for installation to the original purchaser.

Items specifically covered are:

- Electrical harnesses and harness installation
- Printed circuit board
- Switches, circuit breakers and relays

Items excluded are:

- Chassis electrical systems and components installed by chassis manufacturer
- Separately manufactured items installed by Alexis Fire Equipment including, but not limited to; batteries, sirens, battery chargers, inverters, lightbars and similar equipment. (These are covered by warranties supplied by the manufacturer of the components).
- Periodic tightening and cleaning of connection terminals as this is considered routine maintenance
- Normal wear, abuse, accident, negligence or un-approved alteration of original parts.

Should repairs become necessary under the terms of this warranty, the extent of that repair shall be determined solely by Alexis Fire Equipment and shall be performed solely by Alexis Fire Equipment or a repair facility designated by Alexis. The expense of any transportation to or from such repair facility shall be that of the purchaser and is not an item covered by this warranty.

Alexis Fire Equipment reserves the un-restricted right at any time to make changes in design of and/or improvements on its products without thereby imposing any obligation on itself to make corresponding changes or improvements in or on its products theretofore manufactured.

12 VOLT ELECTRICAL SYSTEM:

Our electrical system is engineered to provide many years of dependable, trouble free service.

The 12 volt apparatus wiring shall be completely independent of the chassis electrical system. The system shall incorporate a state-of-the-art electrical distribution center. The center shall include a microprocessor, automatic reset circuit breakers, and switching relays.

The microprocessors are housed in a weather resistant enclosure. All processors are fully tested, and modern production processes guarantee long-term reliability in the most rigorous environments. The microprocessors handle the numerous switching functions without the excessive use of relays and the

need for excess wiring.

The system can be expanded by adding additional processors and required components to meet desired specifications.

The weather tight modular service center shall be placed in a water-tight compartment in the apparatus body. The service center housing shall be manufactured of aluminum and shall incorporate an access door. Since the microprocessor is of weather resistant design and enclosed in the service center, the electrical system has redundant protection against moisture and corrosion. Redundant protection from the elements dramatically improves reliability and durability.

Wiring harnesses shall be custom made for each truck. Each harness shall be encased in a split barrel, nylon type loom which will be moisture resistant and flame resistant to a minimum of 280° F. Loop outs shall be made at the harness factory utilizing sealed sonic weld technology instead of open-ended butt splicing. The harnesses shall feature Deutsch heavy duty all metal connectors.

Unlike terminal strips, binding post and other open-wiring systems, the Deutsch HD series is a completely sealed unit. The elimination of open wiring systems does away with contamination from moisture, dust, lubricating oils, road salt, and other environmental hazards encountered in heavy duty use. The connector shall provide a multiple keying system that positively prevents mis-mating and makes plug/receptacle coupling quick and easy. The modular harness system will allow for quick and efficient complete body transfer if needed.

An independent switching station shall be centrally located in the apparatus cab. The switches shall be of a rocker type illuminating design. Each switch shall be color coded, and include a description indicating its intended use. Each switch shall be removable for service and replacement. Each switch shall be rated at 10 amp at 250 volts AC and shall act as inputs for the microprocessor.

All electrical circuit feeder wiring supplied and installed by the apparatus manufacturer shall be stranded copper alloy conductors of a gauge rated to carry 125% of the maximum current for which the circuit is protected. Insulation shall be in accordance with SAE J1128, low tension primary cable, type SXL or GXL, and wired to SAE J1292, automobile, truck, truck-tractor, trailer and motor coach wiring, for such loading at the potential employed. Voltage drops in all wiring from the power source to the using device shall not exceed 10%. Overall covering of conductors shall be 280° F (143° C) minimum flame retardant, moisture resistant loom or braid. All connections shall be made with lugs or terminals mechanically secured to the conductors. Wiring shall be thoroughly secured in place and suitably protected against heat, oil, and physical damage. Wiring shall be color coded and printed with a circuit function code over each conductor's entire length.

Circuits shall be provided with properly rated low voltage over-current protective devices. Such devices

shall be readily accessible and protected against excessive heat, physical damage and water spray, switches relays, terminals, and connectors shall have a direct current rating of 125% of maximum current for which the circuit is protected.

Wiring Diagrams: Two (2) destination effective wiring diagrams shall be furnished with the apparatus. The wiring diagrams shall incorporate notations to assist an individual with limited electrical experience in the service of the apparatus electrical system.

NOTE: All wiring and components shall meet or exceed current N.F.P.A. codes.

LOAD MANAGEMENT:

The 12 volt load management functions shall be incorporated within the microprocessor based 12 Volt electrical system without the need for a separate load manager.

12 VOLT DISTRIBUTION CENTER:

The 12 Volt distribution center shall be located in the L1 compartment on the front wall, behind an access panel. The access panel shall incorporate a laminated wiring diagram for ease of maintenance of the electrical system.

A 12 volt fan shall be provided in the distribution center to enhance the air flow around the electrical equipment. The fan shall be switched with the master switch.

ELECTRICAL SYSTEM PERFORMANCE TESTS:

The apparatus low voltage electrical system shall be tested and certified per the current NFPA standard. The certification shall be delivered to the purchaser with the apparatus.

DOCUMENTATION:

At the time of delivery, the manufacturer shall provide the following:

- (a) Documentation of the electrical system performance tests;
- (b) A written load analysis, including:
 1. The nameplate rating of the alternator;
 2. The alternator rating;
 3. Each component load comprising the minimum continuous load;
 4. Additional loads that, when added to the minimum continuous load, determine the total

connected load;

5. Each individual intermittent load.

BATTERY CHARGER/AIR COMPRESSOR:

One (1) Progressive Dynamics PD2140 battery charger shall be installed on the vehicle. The unit shall be located in the L1 compartment.

The PD2140 is a 40-amp Electronic Marine Converter/Charger capable of charging up to three separate banks of batteries at the same time. It incorporates a microprocessor that constantly monitors battery voltage, then automatically selects one of four operating modes to ensure safe, rapid recharging cycles. The Storage Mode and the Equalize Mode of operation ensures minimum battery gassing and water loss while preventing battery stratification and sulfation. All Intelli-Power chargers are designed to meet the stringent requirements of the Marine environment and are UL listed for safety. A digital meter displays current, voltage, operation mode, blown fuse indication, and battery type.

One (1) Viair Model 460C air compressor shall be installed on the vehicle. The air compressor is a fully automatic system which is powered from the chassis battery bank through the PD2140 charger system.

REMOTE DISPLAY:

A Blue Sea 1733 Mini digital display shall be supplied and installed adjacent to the shoreline connection. The display monitors DC voltage on a bright, waterproof, daylight readable OLED screen.

KUSSMAUL SUPER AUTO EJECT - 120V:

One (1) Kussmaul super auto eject Model 091-55-20-120 shall be installed on the apparatus. The super auto eject is a completely sealed automatic power line disconnect.

The Kussmaul mating connector supplied with the Auto Eject shall be shipped loose with the apparatus.

The Kussmaul Super Auto Eject shall incorporate a yellow weatherproof cover

The shoreline connection shall be located in the left front body post ahead of the L1 compartment.

MASTER SWITCH:

A 12 Volt Cole-Hersee Rotary switch shall be installed on the side of the floor mounted console. When in the OFF position, the master switch system shall isolate all electrical power from the apparatus. It shall not interrupt any primary battery/starter wiring originally furnished by the chassis manufacturer.



FLOOR MOUNTED CONSOLE FOR EMERGENCY SWITCHES:

One (1) 12 volt floor mounted console shall be installed in the apparatus. The console shall be manufactured of black textured composite material. The console shall incorporate the switch row and two (2) slots, one (1) for the electronic siren and one (1) slot for the radio.

MAP/BINDER STORAGE: IN STOCK

There shall be a stainless steel map/binder storage area incorporated into the console at the rear. The storage area shall incorporate one (1) divider, providing two (2) slots for map/binder storage.

RADIO PROVISIONS:

One (1) customer supplied single head radio provision shall be provided in the chassis cab. The cutout shall accommodate the radio make and model specified and shall include a bezel specific to the radio specified.

RADIO WIRING:

Radio wiring shall be provided for the customer supplied and installed radio. The wiring shall include power and ground leads, battery direct and master switched.

ANTENNA:

One (1) Alexis Fire Equipment supplied antenna base, for use with an NMO type antenna, shall be mounted on the cab roof. The antenna base shall be a Motorola base designed for either thick or thin roof material as appropriate for the application and shall include a custom length of RG58 A/U cable with no connector at the radio end of the cable. The cable shall terminate at the center console area.

The radio make and model shall be:_____

TIRE PRESSURE MONITORING DEVICE:

One (1) set of Real Wheels LED Air Guard tire pressure indicators shall be shipped loose with the completed apparatus. Features and benefits of the LED Air Guards include

- Safety – Improper tire pressure has a detrimental effect on handling, braking and control.
- Longer Tire Life – According to the D.O.T., 95% of all premature tire wear is caused by underinflation.

- Self-calibrating – LED AirGuard Set & Go memorizes pressure when initially installed and can be easily recalibrated by simply removing and reinstalling.
- Improved Fuel Economy – Proper tire inflation can save an estimated 3% to 5% in fuel costs.
- Battery Standby Time is 2 Years from the date stamped on the LED Air Guard

OPTICAL WARNING SYSTEM:

The optical warning system on the fire apparatus shall be capable of two separate signaling modes during emergency operations. One mode shall signal to drivers and pedestrians that the apparatus is responding to an emergency and is calling for the right-of-way. The other mode shall signal that the apparatus is stopped and is blocking the right-of-way.

EMERGENCY WARNING LIGHTS:

For the purpose of defining and measuring the required optical performance, the apparatus shall be divided into four warning zones. The four zones shall be determined by drawing lines through the geometric center of the apparatus at 45° to a line lengthwise of the apparatus through the geometric center. The four zones shall be designated A, B, C, and D in a clockwise direction with zone A to the front of the apparatus. Each zone shall have an upper and lower warning level.

Effective coverage of all four zones, both upper and lower, as required by the latest NFPA Edition shall be provided.

LED LIGHTBAR:

One (1) Whelen Model F4N2VLED 55" LED lightbar shall be mounted on the cab roof. The lightbar shall be switched from the in cab switch panel. This lightbar fills the requirements of Zone A Upper, Zone B Upper, and Zone D Upper.

The light bar shall feature four (4) corner red LED modules, two (2) forward facing red LED modules, and two (2) forward facing clear LED Modules.

The clear modules shall extinguish when blocking the right of way per NFPA. A stinger switch shall also be provided for control of the white lights in inclement weather.

WARNING LIGHTS (FRONT):

Two (2) Tecniq Model K60-R*00-1 Red LED warning lights shall be mounted on the front cab face, one (1) on each side. These lights shall be switched from the in cab switch panel. These lights fill the requirements of Zone A Lower.



Each light shall be mounted utilizing a chrome plated flange.

Each light shall incorporate a colored lens.

WARNING LIGHTS (SIDE):

One (1) Tecniq Model K60-R*00-1 Red LED warning light shall be mounted on the right (officer's) side of the cab. The light shall be switched from the in cab switch panel. The light fills the requirements of Zone B Lower.

One (1) Tecniq Model K60-R*00-1 Red LED warning light shall be mounted on the left (driver's) side of the cab. The light shall be switched from the in cab switch panel. The light fills the requirements of Zone D Lower.

The rub rails on each side of the body shall incorporate integral outward facing Red LED strip lights. In addition to the Red LED strip light, the rub rail on each side ahead of the rear wheels shall incorporate one (1) TecNiq E03-D001-1 LED light. These lights shall be switched from the in cab switch panel.

In addition to the Tecniq Red Eon LED light in the rub rail ahead of the rear wheels on each side, one (1) additional Tecniq Red Eon LED light shall be provided in the rub rail behind the rear wheels on each side. These lights shall be switched from the in cab switch panel.

Each cab side light shall be mounted utilizing a chrome plated flange.

Each light shall incorporate a colored lens.

WARNING LIGHTS (REAR UPPER):

Two (2) Whelen Model L31HRFN Red LED beacon warning lights shall be mounted on the upper rear area of the vehicle, one (1) each side. These beacons shall be switched from the in cab switch panel. These beacons fill the requirements of Zone C Upper, Zone B Upper, and Zone D Upper.

WARNING LIGHTS (REAR):

Two (2) Tecniq Model K60-R*00-1 Red LED warning lights shall be mounted on the lower rear area of the vehicle. These lights shall be switched from the in cab switch panel. These lights fill the requirements of Zone C Lower.



Each light shall be mounted utilizing a chrome plated flange.

Each light shall incorporate a colored lens.

REAR DRIVING SIGNALS:

The rear driving signals shall consist of two (2) Code 3 7X9STTRBZ LED lights, one (1) each side of the apparatus at the rear. The 7X9 LED lights shall incorporate red brake/tail, amber turn, and white backup in a single light head. The mounting shall include a chrome bezel.

ELECTRONIC SIREN:

One (1) Whelen Model 295SLSA1 siren shall be installed in the apparatus. The siren shall be mounted in the cab and shall include a noise-canceling microphone.

SIREN SPEAKER:

One (1) Whelen Model SA315 100 watt siren speaker shall be installed in the apparatus bumper.

BACKUP ALARM:

One (1) 12 volt electronic backup alarm shall be incorporated on the apparatus. The backup alarm shall be a minimum of 97db and switched with the backup light circuitry.

TURN SIGNALS-MIDSHIP:

One (1) S34 Series amber LED midship turn light shall be mounted on each side of the apparatus ahead of the rear wheels.

ICC LIGHTING:

Tecniq S34 Series LED Clearance lights shall be installed on the apparatus. They shall be hermetically sealed cartridge lights for ease of service and durability.

LED REAR LICENSE PLATE BRACKET:

There shall be a Cast Products LED license plate bracket provided at the rear of the apparatus.

ENGINE COMPARTMENT LIGHT:



The engine compartment shall incorporate one (1) E10 Series LED light. The light shall be switched with the pump panel lights.

PUMP COMPARTMENT LIGHT:

One (1) 5" T44 Series LED light shall be installed in the pump compartment. The light shall be switched with pump panel lights.

HAZARD LIGHT:

A red, LED flashing light located in the driving compartment shall be illuminated automatically whenever the apparatus parking brake is not fully engaged and any passenger or equipment compartment door is open, any ladder or equipment rack is not in the stowed position, a stabilizer system is deployed, a powered light tower is extended, or any other device is opened, extended, or deployed that creates a hazard or is likely to cause damage to the apparatus if the apparatus is moved. The light shall be marked "Do Not Move Apparatus When Light Is On".

LED COURTESY LIGHTS (UNDER CARRIAGE LIGHTING):

One (1) 5" 12-volt T44 Series LED light shall be located under each cab door and one (1) shall be located below the rear tail step in the center. All ground area lighting shall be controlled by the master switch and shall be switched with the parking brake.

In addition to the 5" lights, clear LED strip lights shall be provided integral to the rub rails on each side. The strip lights shall face downward and be activated with the balance of the undercarriage lighting.

LED TAILBOARD COURTESY LIGHTS:

Two (2) S34 Series LED courtesy lights shall be mounted one (1) each side low on the rear panel. The lights shall illuminate the rear tailboard. They shall be switched with the parking brake.

LED RUNNING BOARD COURTESY LIGHTS:

One (1) S34 Series LED courtesy light shall be mounted on each side low on the front of the body. Each light shall illuminate the running board area. The lights shall be switched with the parking brake.

SCENE LIGHTS:

Four (4) LED scene light(s), Whelen Model 9SC0ENZR with 6500 lumen output, shall be mounted in the specified location(s). Each scene light shall be switched from the cab console.



Each light shall be mounted utilizing a chrome plated flange.

SIDE SCENE LIGHT LOCATION(S): Two (2) Each Side

SCENE LIGHTS:

Two (2) LED scene light(s), Whelen Model 9SC0ENZR with 6500 lumen output, shall be mounted in the specified location(s). Each scene light shall be switched from the cab console.

Each light shall be mounted utilizing a chrome plated flange.

REAR SCENE LIGHT LOCATION(S): One (1) Each Side

HOSEBED STRIP LIGHTING - LED:

Two (2) E45 Series LED Strip lights shall be provided at the front of the apparatus hose bed. The lights shall be switched with the parking brake.

12 VOLT BROW LIGHT - LED:

One (1) 21" FireTech Model FT-MB-2.18-FT-* 19,008 lumen LED light bar shall be mounted above the center of the windshield. The light shall be switched from the in-cab switching console.

Each Firetech Hi-Viz scene light shall be white in color.

BACK-UP CAMERA: IN STOCK

There shall be one (1) RV Cams Voyager Color Observation back-up camera system installed on the apparatus. The system includes one (1) 7" mirror mount color video monitor, color camera, three (3) camera input receiver, and camera cable.

The camera shall feature one-way audio from the rear of the apparatus to the cab.

BRACKETING:

GRAB HANDLES:

Two (2) 18" knurled bright stainless steel 1¼" O.D. grab rails shall be installed vertically at the rear of the apparatus.

Each grab handle shall have a natural stainless steel finish

GRAB HANDLE:

One (1) 48" knurled bright stainless steel 1¼" O.D. grab rail shall be installed horizontally below the apparatus hose bed.

Each grab handle shall have a natural stainless steel finish

WHEEL CHOCKS:

One (1) pair of Worden Safety Model WC2556A one-piece rubber wheel chocks shall be provided with the apparatus. Each chock features a molded in grab handle, an elbow fixture for rope or chain attachment, and utilizes a very sticky live rubber to ensure high coefficient of friction.

FINISH:

APPARATUS BODY FINISH:

The final finish of the apparatus shall conform to fire apparatus standards, exhibiting excellent gloss durability and color retention properties.

PREPARATION:

Since the removal of all contaminants and oxidation is essential to the final effect of a finish system, the apparatus shall be pre-cleaned with wax and grease remover and towel dried prior to evaporation.

A 10-step standard body preparation shall be completed.

When the substrate is prepared, the entire body shall be cleaned by washing again with wax and grease remover and towel dried.

PRETREAT AND PRIMERS:

The pretreat and primer applications shall be made in two (2) independent steps. A application of a combined pretreat/primer product will not be allowed as a substitute.

The prepared substrate shall be pretreated with Acid Curing 2 Component Transparent Primer. This pretreat shall be designed to provide corrosion protection and to create an adhesive bond between the



substrate and the surface applications.

To enhance adhesion and top coat gloss, a 2 component epoxy primer shall be applied.

All the primed surfaces shall be sanded smooth, thus removing all texture and surface imperfections and creating a finish base that will meet the rigid requirements of the fire and emergency services.

TOP COATS:

Two (2) coats (0.5 - 2.0 mils) urethane base coat shall be applied in a professional manner. After the base coats have cured properly, two (2) coats of a high solids urethane clear coat shall be applied.

All surface imperfections shall be removed by buffing and polishing.

PAINT WARRANTY:

The apparatus shall be covered by a ten -(10) year paint warranty. Following are the covered defects and exclusions.

Covered Defects shall include only the following list of defects:

- Peeling or delaminating of the topcoat and/or other layers of paint.
- Cracking or checking.
- Loss of gloss caused by cracking, checking or hazing.

Defects resulting from the following conditions are excluded from the Warranty:

- Hazing, chalking or loss of gloss caused by improper care, abrasive polishes, cleaning agents, heavy-duty pressure washing, or aggressive mechanical wash systems
- Rock chips are not covered under this warranty.
- Paint deteriorating caused by abuse, scratches, chips, gloss reduction, accidents, acid rain, chemical fallout or acts of nature
- Claims presented without proper Warranty documentation
- Failure on finishes performed by Non-PPG Commercial Certified Technicians
- Failures on finishes due to inadequate film builds
- Failures due to improper cleaning or surface preparation or failure to follow the product use instructions

The front corners of the body shall remain natural finish #4 stainless steel. The material be full height and shall wrap around each corner to the compartment door frame.



The rear corners of the body shall remain natural finish #4 stainless steel. The material be full height and shall wrap around each corner to the compartment door frame.

The rear wheel housing and center door posts on each side shall be #4 finish stainless steel

The compartment header on each side above the door openings shall be #4 finish stainless steel

COMPARTMENT INTERIOR FINISH:

The interior of the compartments shall be natural finish stainless steel

APPARATUS COLOR:

The color of the apparatus shall be as follows:

COLOR: _____

CAB LETTERING:

Vinyl lettering as described below shall be applied to the chassis cab door, one (1) each side. Each letter shall be 2½" to 3½" high and hand applied.

Vinyl letters/numbers shall be applied to the chassis cab fender area, one (1) each side. Each letter/number shall be 2½" to 3½" high and hand applied.

The lettering vinyl style shall be simulated gold leaf.

The lettering font style shall be Eurostile Bold.

The lettering font highlight type shall be shadow.

LAMINATION WARRANTY:

The apparatus shall be covered by a three (3) year warranty against defects in material and workmanship with the graphics process

REFLECTIVE STRIPING:

The finished apparatus shall be striped with 6" reflective Scotchlite striping.



The reflective striping shall be white in color.

REFLECTIVE STRIPING IN THE CAB:

Two-inch red and white striped retro-reflective material shall be placed on the inside of each opening cab door. The material will be at least 96 square inches, meeting current NFPA standards.

DIAMOND GRADE CHEVRON STRIPING:

The rear of the apparatus shall be striped with Diamond Grade retro-reflective striping. The striping shall be applied in a chevron pattern sloping downward and away from the centerline of the apparatus at a 45° angle. The Chevron striping shall be applied in the following locations: all vertical surfaces at the rear, from the tail step to the top of the body

The striping shall be single color alternating between red #3992 and fluorescent yellow-green #3983.

EQUIPMENT:

One (1) bottle of touch up paint for each color on the apparatus

One (1) bag of hardware - nuts, bolts, drill, and tap.

Two (2) 10' Length(s) of 6" diameter hard suction hose, coupled 6" LHF x 6" RLM. (Not rated for hydrants)

One (1) Fol-Da-Tank(s) #FDT-2100, steel frame, 22 ounce red HPR material. The tank shall include liner pick-up handles.

Two (2) Alexis Spanner Wrench Set, includes mounting plate and four (4) super spanner wrenches, **Mounted.**

ONE AT THE PUMP PANEL, ONE APPARATUS REAR

ITEM IN STOCK

LOCATION: _____

NFPA EQUIPMENT CLARIFICATION:



 Alexis Fire Equipment
109 East Broadway / Alexis, IL 61412
 800-322-2284  sales@alexisfire.com
 AlexisFire.com

Any equipment specified in the “Equipment” section (e.g. hose, nozzles, adapters, AED, traffic cones, traffic safety vests, etc.) of NFPA 1900 Sections 8.4 and A.8.4 tables a, bc, and c for each apparatus classification which is not specified in this proposal shall be considered to be customer supplied and installed.



HOSE CAPACITIES

DWG NO.

T-N45

11/6/2024

Customer Alexis Fire Equip
 Calculated By M. Tinkham

Contract No. 2675
 Rev. No. 0

HOSE BED

Length	119	
Width	78	
Height	13	
Cu. Ft.	69.83	0.00

Total **69.83**

Hose Size				
Amount				
DF	0	0	0	0
Cu. Ft.	0.00	0.00	0.00	0.00

Total **0.00**
 Need **0.00**

MATTYDALES

Length	73	73	73
Width	4.75	4.5	4.5
Height	26	26	26
Cu. Ft.	5.22	4.94	4.94

Total **15.10**

Hose Size	2 1/2	1 3/4	1 3/4
Amount	150	200	200
DF	41	26	26
Cu. Ft.	3.56	3.01	3.01

Total **9.58**

CARTRIDGE LAYS

Length			
Width			
Height			
Cu. Ft.	0.00	0.00	0.00

Total **0.00**

Hose Size			
Amount			
DF	0	0	0
Cu. Ft.	0.00	0.00	0.00

Total **0.00**

HOSE TRAYS

Length			
Width			
Height			
Cu. Ft.	0.00	0.00	0.00

Total **0.00**

Hose Size			
Amount			
DF	0	0	0
Cu. Ft.	0.00	0.00	0.00

Total **0.00**

HOSE WELLS

Length			
Width			
Height			
Cu. Ft.	0.00	0.00	0.00

Total **0.00**

Hose Size			
Amount			
DF	0	0	0
Cu. Ft.	0.00	0.00	0.00

Total **0.00**

Standard Hose Dimensions per NFPA (2003 Edition)

1 3/4" lays 3 1/4" wide	DF=	26	1" FORESTRY lays 1 3/4" wide	DF=	10
2" (ANGUS) lays 3 3/4" wide	DF=	32	1 1/2" FORESTRY 2 1/2" wide	DF=	14
2 1/2" lays 4 1/2" wide	DF=	41			
3" lays 5 1/4" wide	DF=	50			
4" lays 6 1/2" wide	DF=	58			
5" lays 8" wide - Angus	DF=	96			
5" lays 8-1/2" wide - Cotton	DF=	102			
6" lays 9 1/2" wide	DF=	108			

Prepared for:
 JEFF MORRIS
 ALEXIS FIRE EQUIPMENT CO
 (BB)
 109 EAST BROADWAY
 ALEXIS, IL 61412
 Phone: 309-937-3800

Prepared by:
 Duane Schaefer
 TRANSCHICAGO TRUCK
 GROUP
 776 N. YORK STREET
 ELMHURST, IL 60126
 Phone: 815-509-9079

S P E C I F I C A T I O N P R O P O S A L

Description	Weight Front	Weight Rear
Price Level		
M2 PRL-28M (EFF:MY25 ORDERS)		
Data Version		
SPECPRO21 DATA RELEASE VER 049		
Vehicle Configuration		
M2 112 PLUS CONVENTIONAL CHASSIS	8,244	6,026
2025 MODEL YEAR SPECIFIED		
SET BACK AXLE - TRUCK		
STRAIGHT TRUCK PROVISION, NON-TOWING		
LH PRIMARY STEERING LOCATION		
General Service		
TRUCK CONFIGURATION		
DOMICILED, USA 50 STATES (INCLUDING CALIFORNIA AND CARB OPT-IN STATES)		
EPA EMISSIONS CERTIFICATION FOR 50 STATE REGISTRATION - CARB EXEMPT, FIRE, EMERGENCY AND MILITARY VEHICLES ONLY (INCLUDES 6X4 INCH LABEL ON LOWER FORWARD OF DRIVER DOOR)		
NONE		
FIRE SERVICE		
EMERGENCY VEHICLES BUSINESS SEGMENT		
LIQUID BULK COMMODITY		
TERRAIN/DUTY: 100% (ALL) OF THE TIME, IN TRANSIT, IS SPENT ON PAVED ROADS		
MAXIMUM 8% EXPECTED GRADE		
SMOOTH CONCRETE OR ASPHALT PAVEMENT - MOST SEVERE IN-TRANSIT (BETWEEN SITES) ROAD SURFACE		
FREIGHTLINER LEVEL II WARRANTY		
EXPECTED FRONT AXLE(S) LOAD : 16000.0 lbs		



Prepared for:
 JEFF MORRIS
 ALEXIS FIRE EQUIPMENT CO
 (BB)
 109 EAST BROADWAY
 ALEXIS, IL 61412
 Phone: 309-937-3800

Prepared by:
 Duane Schaefer
 TRANSCHICAGO TRUCK
 GROUP
 776 N. YORK STREET
 ELMHURST, IL 60126
 Phone: 815-509-9079

Description	Weight Front	Weight Rear
EXPECTED REAR DRIVE AXLE(S) LOAD : 31000.0 lbs		
EXPECTED GROSS VEHICLE WEIGHT CAPACITY : 47000.0 lbs		

Truck Service

FIRE TANK - NO MAIN DRIVELINE DRIVEN SPLIT-SHAFT PTO/PUMP
 EXPECTED TRUCK BODY LENGTH : 16.0 ft
 ALEXIS FIRE EQUIPMENT COMPANY
 APPROVAL TO SHARE SPEC WITH TEM
 EXPECTED BODY/PAYLOAD CG HEIGHT ABOVE FRAME "XX" INCHES : 32.0 in

Engine

CUM L9 450EV HP @ 2100 RPM; 2200 GOV RPM, 1250 LB-FT @ 1200 RPM, R/F/E	-850	-70
--	------	-----

Electronic Parameters

68 MPH ROAD SPEED LIMIT
 CRUISE CONTROL SPEED LIMIT SAME AS ROAD SPEED LIMIT
 PTO MODE BRAKE OVERRIDE - SERVICE BRAKE APPLIED
 PTO RPM WITH CRUISE SET SWITCH - 1100 RPM
 PTO RPM WITH CRUISE RESUME SWITCH - 1100 RPM
 PTO MODE CANCEL VEHICLE SPEED - 5 MPH
 PTO GOVERNOR RAMP RATE - 250 RPM PER SECOND
 FUEL DOSING OF AFTERTREATMENT ENABLED IN PTO MODE-CLEANS HYDROCARBONS AT HIGH TEMPERATURES ONLY
 ONE TEM PTO SPEED
 PTO SPEED 1 SETTING - 750 RPM
 PTO MINIMUM RPM - 700
 REGEN INHIBIT SPEED THRESHOLD - 5 MPH
 PTO 1, WITH SWITCH, TEM SUPPLIED REQUEST AND INTERLOCKS, WITH PTO CONNECTIONS, STATIONARY INTERLOCKS

Engine Equipment

EPA 2010/GHG 2024 CONFIGURATION
 STANDARD OIL PAN



Prepared for:
 JEFF MORRIS
 ALEXIS FIRE EQUIPMENT CO
 (BB)
 109 EAST BROADWAY
 ALEXIS, IL 61412
 Phone: 309-937-3800

Prepared by:
 Duane Schaefer
 TRANSCHICAGO TRUCK
 GROUP
 776 N. YORK STREET
 ELMHURST, IL 60126
 Phone: 815-509-9079

Description	Weight Front	Weight Rear
ENGINE MOUNTED OIL CHECK AND FILL		
SIDE OF HOOD AIR INTAKE WITH NFPA COMPLIANT EMBER SCREEN AND FIRE RETARDANT DONALDSON AIR CLEANER		
LN 12V 325 AMP BLP4002H BRUSHLESS PAD ALTERNATOR WITH REMOTE SENSE AND LAMP TERMINAL	10	
(2) DTNA GENUINE, FLOODED STARTING, MIN 2000CCA, 370RC, THREADED STUD BATTERIES	-40	-10
BATTERY BOX FRAME MOUNTED		
STANDARD BATTERY JUMPERS		
SINGLE BATTERY BOX FRAME MOUNTED LH SIDE UNDER CAB		
WIRE GROUND RETURN FOR BATTERY CABLES WITH ADDITIONAL FRAME GROUND RETURN		
NON-POLISHED BATTERY BOX COVER		
POSITIVE LOAD DISCONNECT WITH CAB MOUNTED CONTROL SWITCH MOUNTED OUTBOARD DRIVER SEAT	2	
POSITIVE AND NEGATIVE POSTS FOR JUMPSTART LOCATED ON FRAME NEXT TO STARTER	2	
PROGRESSIVE LOW VOLTAGE DISCONNECT AT 12.3 VOLTS FOR DESIGNATED CIRCUITS		
CUMMINS TURBOCHARGED 18.7 CFM AIR COMPRESSOR WITH INTERNAL SAFETY VALVE		
STANDARD MECHANICAL AIR COMPRESSOR GOVERNOR		
AIR COMPRESSOR DISCHARGE LINE		
GVG, FIRE AND EMERGENCY SERVICE VEHICLES ENGINE WARNING		
C-BRAKE BY JACOBS WITH LOW/OFF/HIGH BRAKING DASH SWITCH	80	
RH OUTBOARD UNDER STEP MOUNTED HORIZONTAL AFTERTREATMENT SYSTEM ASSEMBLY WITH RH HORIZONTAL TAILPIPE EXITING FORWARD OF REAR TIRES	10	5
ENGINE AFTERTREATMENT DEVICE, AUTOMATIC OVER THE ROAD ACTIVE REGENERATION AND VIRTUAL REGENERATION REQUEST SWITCH IN CLUSTER AND DASH MOUNTED INHIBIT SWITCH		
STANDARD EXHAUST SYSTEM LENGTH		
RH HORIZONTAL TAILPIPE, EXIT FORWARD OF REAR TIRES	20	20

Application Version 11.9.805
 Harwington CT MY25 M2112
 ChecCam L9 RC...



07/17/2024 8:16 PM

Page 4 of 24

Prepared for:
 JEFF MORRIS
 ALEXIS FIRE EQUIPMENT CO
 (BB)
 109 EAST BROADWAY
 ALEXIS, IL 61412
 Phone: 309-937-3800

Prepared by:
 Duane Schaefer
 TRANSCHICAGO TRUCK
 GROUP
 776 N. YORK STREET
 ELMHURST, IL 60126
 Phone: 815-509-9079

Description	Weight Front	Weight Rear
6 GALLON DIESEL EXHAUST FLUID TANK		
100 PERCENT DIESEL EXHAUST FLUID FILL		
LH MEDIUM DUTY STANDARD DIESEL EXHAUST FLUID TANK LOCATION		
STANDARD DIESEL EXHAUST FLUID PUMP MOUNTING		
STANDARD DIESEL EXHAUST FLUID TANK CAP		
HIGH SPEED AIR POWERED ON/OFF ENGINE FAN CLUTCH		
AUTOMATIC FAN CONTROL WITHOUT DASH SWITCH, NON ENGINE MOUNTED		
CUMMINS SPIN ON FUEL FILTER		
COMBINATION FULL FLOW/BYPASS OIL FILTER		
FLEETGUARD PLAIN COOLANT FILTER		
1300 SQUARE INCH ALUMINUM RADIATOR	-20	
ANTIFREEZE TO -34F, OAT (NITRITE AND SILICATE FREE) EXTENDED LIFE COOLANT		
GATES BLUE STRIPE COOLANT HOSES OR EQUIVALENT		
CONSTANT TENSION HOSE CLAMPS FOR COOLANT HOSES		
ALUMINUM FLYWHEEL HOUSING		
ELECTRIC GRID AIR INTAKE WARMER		
DELCO 12V 38MT HD STARTER WITH INTEGRATED MAGNETIC SWITCH	-10	
Transmission		
ALLISON 3000 EVS AUTOMATIC TRANSMISSION WITH PTO PROVISION	-80	-20

Transmission Equipment

ALLISON VOCATIONAL PACKAGE 198 -
 AVAILABLE ON 3000/4000 PRODUCT FAMILIES
 WITH VOCATIONAL MODEL EVS
 ALLISON VOCATIONAL RATING FOR FIRE
 TRUCK/EMERGENCY VEHICLE APPLICATIONS
 AVAILABLE WITH ALL PRODUCT FAMILIES
 PRIMARY MODE GEARS, LOWEST GEAR 1,
 START GEAR 1, HIGHEST GEAR 6, AVAILABLE
 FOR 3000/4000 PRODUCT FAMILIES ONLY
 SECONDARY MODE GEARS, LOWEST GEAR 1,
 START GEAR 1, HIGHEST GEAR 6, AVAILABLE
 FOR 3000/4000 PRODUCT FAMILIES ONLY



Prepared for:
 JEFF MORRIS
 ALEXIS FIRE EQUIPMENT CO
 (BB)
 109 EAST BROADWAY
 ALEXIS, IL 61412
 Phone: 309-937-3800

Prepared by:
 Duane Schaefer
 TRANSCHICAGO TRUCK
 GROUP
 776 N. YORK STREET
 ELMHURST, IL 60126
 Phone: 815-509-9079

Description	Weight Front	Weight Rear
S5 PERFORMANCE LIMITING PRIMARY SHIFT SCHEDULE, AVAILABLE FOR 3000/4000 PRODUCT FAMILIES ONLY		
S5 PERFORMANCE LIMITING SECONDARY SHIFT SCHEDULE, AVAILABLE FOR 3000/4000 PRODUCT FAMILIES ONLY		
2200 RPM PRIMARY MODE SHIFT SPEED		
2200 RPM SECONDARY MODE SHIFT SPEED		
ENGINE BRAKE RANGE PRESELECT RECOMMENDED BY DTNA AND ALLISON, THIS DEFINED BY ENGINE AND VOCATIONAL USAGE		
ENGINE BRAKE RANGE ALTERNATE PRESELECT RECOMMENDED BY DTNA AND ALLISON, THIS DEFINED BY ENGINE AND VOCATIONAL USAGE		
FUEL SENSE 2.0 DISABLED - PERFORMANCE - TABLE BASED		
DRIVER SWITCH INPUT - DEFAULT - NO SWITCHES		
PUMP MODE INPUT ENABLED 3RD/4TH LOCKUP WIRED ON TCM INPUT AJ/BQ - ALLISON 5TH GEN TRANSMISSIONS		
4TH RANGE INDICATION ON TCM OUTPUT C - ALLISON 5TH GEN TRANSMISSIONS		
QUICKFIT BODY LIGHTING CONNECTOR UNDER CAB, WITH BLUNTCUTS		
ELECTRONIC TRANSMISSION WIRING TO CUSTOMER INTERFACE CONNECTOR		
CUSTOMER INSTALLED CHELSEA 870 SERIES PTO		
PTO MOUNTING, LH SIDE OF MAIN TRANSMISSION ALLISON		
MAGNETIC PLUGS, ENGINE DRAIN, TRANSMISSION DRAIN, AXLE(S) FILL AND DRAIN		
PUSH BUTTON ELECTRONIC SHIFT CONTROL, DASH MOUNTED		
TRANSMISSION PROGNOSTICS - ENABLED 2013		
WATER TO OIL TRANSMISSION COOLER, IN RADIATOR END TANK	15	
TRANSMISSION OIL CHECK AND FILL WITH ELECTRONIC OIL LEVEL CHECK		
SYNTHETIC TRANSMISSION FLUID (TES-295 COMPLIANT)		

Front Axle and Equipment

Application Version 11.9.805
 Harwington CT MY25 M2112
 ChecCam L9 RC...



07/17/2024 8:16 PM

Prepared for:
 JEFF MORRIS
 ALEXIS FIRE EQUIPMENT CO
 (BB)
 109 EAST BROADWAY
 ALEXIS, IL 61412
 Phone: 309-937-3800

Prepared by:
 Duane Schaefer
 TRANSCHICAGO TRUCK
 GROUP
 776 N. YORK STREET
 ELMHURST, IL 60126
 Phone: 815-509-9079

	Description	Weight Front	Weight Rear
	DETROIT DA-F-16.0-5 16,000# FL1 71.0 KPI/3.74 DROP SINGLE FRONT AXLE	190	
	MERITOR 16.5X6 Q+ CAST SPIDER CAM FRONT BRAKES, DOUBLE ANCHOR, FABRICATED SHOES	10	
	FIRE AND EMERGENCY SEVERE SERVICE, NON-ASBESTOS FRONT LINING		
	CAST IRON OUTBOARD FRONT BRAKE DRUMS		
	FRONT OIL SEALS		
	VENTED FRONT HUB CAPS WITH WINDOW, CENTER AND SIDE PLUGS - OIL		
	STANDARD SPINDLE NUTS FOR ALL AXLES		
	MERITOR AUTOMATIC FRONT SLACK ADJUSTERS		
	TRW TAS-85 POWER STEERING	40	
	POWER STEERING PUMP		
	2 QUART SEE THROUGH POWER STEERING RESERVOIR		
	CURRENT AVAILABLE SYNTHETIC 75W-90 FRONT AXLE LUBE		
Front Suspension			
	16,000# FLAT LEAF FRONT SUSPENSION	260	
	GRAPHITE BRONZE BUSHINGS WITH SEALS - FRONT SUSPENSION		
	FRONT SUSPENSION WITH LEFT HAND OFFSET SHACKLE BRACKET	4	
	FRONT SHOCK ABSORBERS		
Rear Axle and Equipment			
N	CUMMINS-MERITOR RS-30-185 31,000# U- SERIES FIRE/EMERGENCY SERVICE SINGLE REAR AXLE		-2,030
	5.86 REAR AXLE RATIO		
	IRON REAR AXLE CARRIER WITH STANDARD AXLE HOUSING		
	MXL 176T MERITOR EXTENDED LUBE MAIN DRIVELINE WITH HALF ROUND YOKES	-25	-25
	DRIVER CONTROLLED TRACTION DIFFERENTIAL - SINGLE REAR AXLE		20
	(1) DRIVER CONTROLLED DIFFERENTIAL LOCK REAR VALVE FOR SINGLE DRIVE AXLE		
	INDICATOR LIGHT FOR EACH DIFFERENTIAL LOCKOUT SWITCH, ENGAGE <5 MPH, DISENGAGE >25 MPH		



Prepared for:
 JEFF MORRIS
 ALEXIS FIRE EQUIPMENT CO
 (BB)
 109 EAST BROADWAY
 ALEXIS, IL 61412
 Phone: 309-937-3800

Prepared by:
 Duane Schaefer
 TRANSCHICAGO TRUCK
 GROUP
 776 N. YORK STREET
 ELMHURST, IL 60126
 Phone: 815-509-9079

Description	Weight Front	Weight Rear
MERITOR 16.5X7 P CAST SPIDER CAM REAR BRAKES, DOUBLE ANCHOR, CAST SHOES		30
FIRE AND EMERGENCY SEVERE SERVICE NON-ASBESTOS REAR BRAKE LINING		
BRAKE CAMS AND CHAMBERS ON FORWARD SIDE OF DRIVE AXLE(S)		
WEBB CAST IRON REAR BRAKE DRUMS		50
REAR OIL SEALS		
BENDIX EVERSURE LONGSTROKE 1-DRIVE AXLE SPRING PARKING CHAMBERS		-20
HALDEX AUTOMATIC REAR SLACK ADJUSTERS		
CURRENT AVAILABLE SYNTHETIC 75W-90 REAR AXLE LUBE		
Rear Suspension		
31,000# FLAT LEAF SPRING REAR SUSPENSION WITH HELPER AND RADIUS ROD FOR FIRE/EMERGENCY SERVICE		140
SPRING SUSPENSION - NO AXLE SPACERS		
STANDARD AXLE SEATS IN AXLE CLAMP GROUP		
FORE/AFT CONTROL RODS		
Pusher / Tag Equipment		
NO PUSHER/TAG BRAKE DUST SHIELDS		
Brake System		
AIR BRAKE PACKAGE		
WABCO 4S/4M ABS WITH TRACTION CONTROL WITH ATC SHUT OFF SWITCH		
REINFORCED NYLON, FABRIC BRAID AND WIRE BRAID CHASSIS AIR LINES		
FIBER BRAID PARKING BRAKE HOSE		
STANDARD BRAKE SYSTEM VALVES		
STANDARD AIR SYSTEM PRESSURE PROTECTION SYSTEM		
STD U.S. FRONT BRAKE VALVE		
RELAY VALVE WITH 5-8 PSI CRACK PRESSURE, NO REAR PROPORTIONING VALVE		
BW AD-9SI BRAKE LINE AIR DRYER WITH HEATER		
AIR DRYER MOUNTED INBOARD ON LH RAIL		



Prepared for:
 JEFF MORRIS
 ALEXIS FIRE EQUIPMENT CO
 (BB)
 109 EAST BROADWAY
 ALEXIS, IL 61412
 Phone: 309-937-3800

Prepared by:
 Duane Schaefer
 TRANSCHICAGO TRUCK
 GROUP
 776 N. YORK STREET
 ELMHURST, IL 60126
 Phone: 815-509-9079

Description	Weight Front	Weight Rear
STEEL AIR TANKS MOUNTED AFT INSIDE AND/OR BELOW FRAME JUST FORWARD OF REAR SUSPENSION, NO TRIPLE OR TORPEDO TANKS PULL CABLES ON ALL AIR RESERVOIR(S)		
Trailer Connections		
NO TRAILER AIR HOSE NO AIR HOSE HANGER NO TRAILER ELECTRICAL CABLE		
Wheelbase & Frame		
4725MM (186 INCH) WHEELBASE		
7/16X3-9/16X11-1/8 INCH STEEL FRAME (11.11MMX282.6MM/0.437X11.13 INCH) 120KSI	130	190
1/4 INCH (6.35MM) C-CHANNEL INNER FRAME REINFORCEMENT	180	370
1975MM (78 INCH) REAR FRAME OVERHANG		
FRAME OVERHANG RANGE: 71 INCH TO 80 INCH	-30	130
CALC'D BACK OF CAB TO REAR SUSP C/L (CA) : 120.47 in		
CALCULATED EFFECTIVE BACK OF CAB TO REAR SUSPENSION C/L (CA) : 117.47 in		
CALC'D FRAME LENGTH - OVERALL : 293.94 in		
CALCULATED FRAME SPACE LH SIDE : 83.79 in		
CALCULATED FRAME SPACE RH SIDE : 87.85 in		
SQUARE END OF FRAME		
FRONT CLOSING CROSSMEMBER		
STANDARD WEIGHT ENGINE CROSSMEMBER		
STANDARD CROSSMEMBER BACK OF TRANSMISSION		
STANDARD MIDSHIP #1 CROSSMEMBER(S)		
STANDARD REAR MOST CROSSMEMBER		
STANDARD SUSPENSION CROSSMEMBER		
Chassis Equipment		
THREE-PIECE 14 INCH CHROME STEEL BUMPER WITH COLLAPSIBLE ENDS AND LH WING CUTOUT FOR FEDERAL MS100/ES100/ES100C SPEAKER		
REMOVABLE FRONT TOW/RECOVERY DEVICE, STORED ON CHASSIS FRAME	15	



Prepared for:
 JEFF MORRIS
 ALEXIS FIRE EQUIPMENT CO
 (BB)
 109 EAST BROADWAY
 ALEXIS, IL 61412
 Phone: 309-937-3800

Prepared by:
 Duane Schaefer
 TRANSCHICAGO TRUCK
 GROUP
 776 N. YORK STREET
 ELMHURST, IL 60126
 Phone: 815-509-9079

Description	Weight Front	Weight Rear
MICHELIN XZU-S2 315/80R22.5 20 PLY RADIAL FRONT TIRES	100	
MICHELIN X WORKS XDY 315/80R22.5 20 PLY RADIAL REAR TIRES		232
Hubs		
CONMET PRESET PLUS PREMIUM IRON FRONT HUBS		
WEBB IRON REAR HUBS		70
Wheels		
ALCOA ULTRA ONE 89U64X 22.5X9.00 10-HUB PILOT 5.99 INSET ALUMINUM FRONT WHEELS	-28	
ALCOA ULTRA ONE 89U64X 22.5X9.00 10-HUB PILOT 5.99 INSET ALUMINUM REAR WHEELS		-56
POLISHED DISC SIDE FRONT WHEELS WITH DURA-BRIGHT FINISH		
POLISHED OUTER (DISHED SIDE) REAR WHEELS WITH OUTER ONLY DURA-BRIGHT FINISH		
BENDIX SMARTIRE TIRE PRESSURE MONITORING SYSTEM WHEEL/RIM MOUNTED SENSORS, ALL AXLES		8
FRONT WHEEL MOUNTING NUTS		
REAR WHEEL MOUNTING NUTS		
NYLON WHEEL GUARDS FRONT AND REAR ALL INTERFACES		
Cab Exterior		
112 INCH BBC FLAT ROOF ALUMINUM CONVENTIONAL CAB		
AIR CAB MOUNTING		
CAB ROOF REINFORCEMENTS FOR ROOF MOUNTED COMPONENTS	2	
NONREMOVABLE BUGSCREEN MOUNTED BEHIND GRILLE		
BOLT-ON MOLDED FLEXIBLE FENDER EXTENSIONS	10	
SAFETY YELLOW LH AND RH INTERIOR GRAB HANDLES AND LH AND RH EXTERIOR GRAB HANDLES WITH SINGLE RUBBER INSERT		
HOOD MOUNTED CHROMED PLASTIC GRILLE		
CHROME HOOD MOUNTED AIR INTAKE GRILLE		
FIBERGLASS HOOD		



Prepared for:
 JEFF MORRIS
 ALEXIS FIRE EQUIPMENT CO
 (BB)
 109 EAST BROADWAY
 ALEXIS, IL 61412
 Phone: 309-937-3800

Prepared by:
 Duane Schaefer
 TRANSCHICAGO TRUCK
 GROUP
 776 N. YORK STREET
 ELMHURST, IL 60126
 Phone: 815-509-9079

Description	Weight Front	Weight Rear
HOOD LINER, ADDED FIREWALL AND FLOOR HEAT INSULATION	5	
DUAL 25 INCH ROUND STUTTER TONE HOOD MOUNTED AIR HORNS WITH DUAL LANYARDS	8	
SINGLE ELECTRIC HORN		
DUAL HORN SHIELDS		
REAR LICENSE PLATE MOUNT END OF FRAME		
LED HEADLIGHT ASSEMBLY AND INCANDESCENT MARKER/TURN LAMP WITH CHROME BEZEL		
LED AERODYNAMIC MARKER LIGHTS		
DAYTIME RUNNING LIGHTS		
OMIT STOP/TAIL/BACKUP LIGHTS AND PROVIDE WIRING WITH SEPARATE STOP/TURN WIRES TO 4 FEET BEYOND END OF FRAME		-5
STANDARD FRONT TURN SIGNAL LAMPS		
AUTOMATIC ON/OFF, ENGINE COMPARTMENT, HOOD ACTIVATED WORK LIGHT WITH MANUAL OVERRIDE	1	
DUAL WEST COAST BRIGHT FINISH HEATED MIRRORS WITH LH AND RH REMOTE		
DOOR MOUNTED MIRRORS		
102 INCH EQUIPMENT WIDTH		
LH AND RH 8 INCH BRIGHT FINISH CONVEX MIRRORS MOUNTED UNDER PRIMARY MIRRORS		
STANDARD SIDE/REAR REFLECTORS		
RH AFTERTREATMENT SYSTEM CAB ACCESS WITH POLISHED DIAMOND PLATE COVER		
63X14 INCH TINTED REAR WINDOW		
TINTED DOOR GLASS LH AND RH WITH TINTED OPERATING WING WINDOWS		
RH AND LH ELECTRIC POWERED WINDOWS		
1-PIECE SOLAR GREEN GLASS WINDSHIELD		
2 GALLON WINDSHIELD WASHER RESERVOIR WITHOUT FLUID LEVEL INDICATOR, FRAME MOUNTED		

Cab Interior

RUGGED TRIM PACKAGE
 GRAY & CARBON VINYL INTERIOR "RUGGED"
 CARBON WITH PREMIUM GUNMETAL ACCENT (RUGGED)



Prepared for:
 JEFF MORRIS
 ALEXIS FIRE EQUIPMENT CO
 (BB)
 109 EAST BROADWAY
 ALEXIS, IL 61412
 Phone: 309-937-3800

Prepared by:
 Duane Schaefer
 TRANSCHICAGO TRUCK
 GROUP
 776 N. YORK STREET
 ELMHURST, IL 60126
 Phone: 815-509-9079

Description	Weight Front	Weight Rear
MOLDED PLASTIC DOOR PANEL		
MOLDED PLASTIC DOOR PANEL		
BLACK MATS WITH SINGLE INSULATION		
(1)DASH MOUNTED 12V POWER OUTLET, (1)DASH MOUNTED DUAL USB-C OUTLET		
FORWARD ROOF MOUNTED CONSOLE		
CENTER STORAGE CONSOLE MOUNTED ON BACKWALL	20	
LH AND RH KICKPLATES		
DIGITAL ALARM CLOCK IN DRIVER DISPLAY		
(2) CUP HOLDERS LH AND RH DASH		
M2/SD DASH		
5 LB. FIRE EXTINGUISHER	10	
HEATER, DEFROSTER AND AIR CONDITIONER		
STANDARD HVAC DUCTING WITH SNOW SHIELD FOR FRESH AIR INTAKE		
MAIN HVAC CONTROLS WITH RECIRCULATION SWITCH		
STANDARD HEATER PLUMBING		
VALEO HEAVY DUTY A/C REFRIGERANT COMPRESSOR		
BINARY CONTROL, R-134A		
PREMIUM INSULATION		
SOLID-STATE CIRCUIT PROTECTION AND FUSES		
12V NEGATIVE GROUND ELECTRICAL SYSTEM		
PREMIUM LED CAB LIGHTING		
NO SECURITY DEVICE		
ALL UNIT(S) KEYED ALIKE WITH CUSTOMER SPECIFIED KEY NUMBER FT1014		
KEY QUANTITY OF 4		
LH AND RH ELECTRIC DOOR LOCKS WITH AUTO UNLOCK FEATURE WHEN DOOR IS SET FROM OPEN TO CLOSED POSITION		
TRIANGULAR REFLECTORS KIT WITHOUT FLARES SHIPPED LOOSE IN CAB	10	
SEATS INC 911 UNIVERSAL SERIES HIGH BACK AIR SUSPENSION DRIVER SEAT WITH NFPA 1901-2009/2016 COMPLIANT SEAT SENSOR	50	



Prepared for:
 JEFF MORRIS
 ALEXIS FIRE EQUIPMENT CO
 (BB)
 109 EAST BROADWAY
 ALEXIS, IL 61412
 Phone: 309-937-3800

Prepared by:
 Duane Schaefer
 TRANSCHICAGO TRUCK
 GROUP
 776 N. YORK STREET
 ELMHURST, IL 60126
 Phone: 815-509-9079

Description	Weight Front	Weight Rear
SEATS INC 911 UNIVERSAL SERIES HIGH BACK AIR SUSPENSION PASSENGER SEAT WITH NFPA 1901-2009/2016 COMPLIANT SEAT SENSOR	40	15
LH AND RH INTEGRAL DOOR PANEL ARMRESTS		
BLACK CORDURA PLUS CLOTH DRIVER SEAT COVER		
BLACK CORDURA PLUS CLOTH PASSENGER SEAT COVER		
NFPA 1901-2009 HIGH VISIBILITY ORANGE SEAT BELTS		
ADJUSTABLE TILT AND TELESCOPING STEERING COLUMN		
4-SPOKE 18 INCH (450MM) BLACK STEERING WHEEL WITH SWITCHES		
DRIVER AND PASSENGER INTERIOR SUN VISORS		
INTERFACE CONNECTORS AND WIRING FOR CUSTOMER PROVIDED LED STEP LIGHTING		

Instruments & Controls

FULLY CONFIGURABLE CENTER INSTRUMENT PANELS
 ENGINE REMOTE INTERFACE WITH PARK BRAKE INTERLOCK
 BRIGHT ARGENT FINISH GAUGE BEZELS
 LOW AIR PRESSURE INDICATOR LIGHT AND AUDIBLE ALARM
 DUAL NEEDLE PRIMARY AND SECONDARY AIR PRESSURE GAUGE
 ELECTRONIC AIR RESTRICTION INDICATOR DISPLAYED IN DRIVER DISPLAY
 ELECTRONIC CRUISE CONTROL WITH CONTROLS ON STEERING WHEEL SPOKES
 KEY OPERATED IGNITION SWITCH AND INTEGRAL START POSITION; 4 POSITION OFF/RUN/START/ACCESSORY
 PREMIUM INSTRUMENT CLUSTER WITH 5.0 INCH TFT COLOR DISPLAY
 DIGITAL PANEL LAMP DIMMER SWITCH IN DRIVER DISPLAY
 HEAVY DUTY ONBOARD DIAGNOSTICS INTERFACE CONNECTOR LOCATED BELOW LH DASH
 2 INCH ELECTRIC FUEL GAUGE



Prepared for:
 JEFF MORRIS
 ALEXIS FIRE EQUIPMENT CO
 (BB)
 109 EAST BROADWAY
 ALEXIS, IL 61412
 Phone: 309-937-3800

Prepared by:
 Duane Schaefer
 TRANSCHICAGO TRUCK
 GROUP
 776 N. YORK STREET
 ELMHURST, IL 60126
 Phone: 815-509-9079

	Description	Weight Front	Weight Rear
	ENGINE REMOTE INTERFACE WITH ONE OR MORE SET SPEEDS		
	QUICKFIT POWERTRAIN INTERFACE CONNECTOR UNDER CAB WITH BLUNTCUTS		
	NO ADDITIONAL EXTRA SWITCH ACCUATORS		
	QUICKFIT PROGRAMMABLE INTERFACE CONNECTOR 1 UNDER CAB, CONNECTOR 2 BETWEEN SEATS, W/BLUNTCUTS		
	ENGINE REMOTE INTERFACE CONNECTOR AT POWERTRAIN INTERFACE CONNECTOR		
	ELECTRICAL ENGINE COOLANT TEMPERATURE GAUGE		
	DIGITAL TRANSMISSION OIL TEMPERATURE IN DRIVER DISPLAY		
	ELECTRONIC OUTSIDE TEMPERATURE SENSOR DISPLAY IN DRIVER MESSAGE CENTER		
	ENGINE AND TRIP HOUR METERS INTEGRAL WITHIN DRIVER DISPLAY		
	PTO CONTROLS FOR ENHANCED VEHICLE ELECTRIC/ELECTRONIC ARCHITECTURE		
	NO OBSTACLE DETECTION SYSTEM		
	NO REVERSE PROXIMITY SENSOR		
	NO DR ASSIST SYSTEM		
	(1) BACKUP CAMERA-END OF FRAME MOUNTED WITH 15 FOOT EXTRA LONG CABLE COILED AT END OF FRAME		
	ELECTRONIC STABILITY CONTROL,4X2 W/SAFETY MIN BODY WEIGHT EXCEEDS 4,000LBS REQ		
	NO LANE DEPARTURE WARNING SYSTEM		
	ELECTRIC ENGINE OIL PRESSURE GAUGE		
N	LEFTHAND/RIGHTHAND OVERHEAD INSTRUMENT PANEL BLANK		
	1 QUIKFIT PROGRAMABLE MODULE (QPMXMC) W/ (8) 20AMP FUSED RELAYS		
	NFPA VEHICLE DATA RECORDER AND SEATBELT DISPLAY		
	RAM MOUNT OVERHEAD CONSOLE WITH POWER AND GROUND		
	7" B-PANEL INTERACTIVE TOUCHSCREEN DISPLAY W/ USB-C, APPLE CARPLAY, ANDROID AUTO, BLUETOOTH/AM/FM/SXM/WB, MICROPHONE		
	DASH MOUNTED RADIO		



Prepared for:
 JEFF MORRIS
 ALEXIS FIRE EQUIPMENT CO
 (BB)
 109 EAST BROADWAY
 ALEXIS, IL 61412
 Phone: 309-937-3800

Prepared by:
 Duane Schaefer
 TRANSSHICAGO TRUCK
 GROUP
 776 N. YORK STREET
 ELMHURST, IL 60126
 Phone: 815-509-9079

Description	Weight Front	Weight Rear
(2) RADIO SPEAKERS IN CAB		
NO AM/FM RADIO ANTENNA		
SHARKFIN MULTI-BAND ANTENNA: AM/FM/WEATHERBAND, WIFI/BLUETOOTH, SDAR/SIRIUSXM, GNSS/GPS		
INTEROPERABLE SDAR ANTENNA		
STANDARD RADIO WIRING WITH STEERING WHEEL CONTROLS		
ELECTRONIC MPH SPEEDOMETER WITH SECONDARY KPH SCALE, WITHOUT ODOMETER		
STANDARD VEHICLE SPEED SENSOR		
ELECTRONIC 3000 RPM TACHOMETER		
DETROIT CONNECT PLATFORM HARDWARE		
3 YEARS DAIMLER CONNECTIVITY BASE PACKAGE ON (FEATURES VARY BY MODEL) POWERED BY DETROIT CONNECT ON CUMMINS ENGINES		
TMC RP1226 ACCESSORY CONNECTOR LOCATED BEHIND PASSENGER SIDE REMOVEABLE DASH PANEL		
IGNITION SWITCH CONTROLLED ENGINE STOP		
NO HARDWIRE SWITCH #1		
NO HARDWIRE SWITCH #2		
NO HARDWIRE SWITCH #3		
NO HARDWIRE SWITCH #4		
PRE-TRIP INSPECTION FEATURE FOR EXTERIOR LAMPS AND SERVICE BRAKES		
(2) OVERHEAD MOUNTED LANYARD CONTROLS: (1) OFFICER AIR HORN AND (1) DRIVER AIR HORN		
NO TRAILER HAND CONTROL BRAKE VALVE		
DIGITAL TURBO AIR PRESSURE IN DRIVER DISPLAY		
DIGITAL VOLTAGE DISPLAY INTEGRAL WITH DRIVER DISPLAY		
SINGLE ELECTRIC WINDSHIELD WIPER MOTOR WITH DELAY WHEN PARK BRAKE SET, TRANSITION TO SLOWEST SPEED		
ROTARY HEADLAMP SWITCH, MARKER LIGHTS/HEADLIGHTS SWITCH WITH PULL OUT FOR OPTIONAL FOG/ROAD LAMPS		
ONE VALVE PARKING BRAKE SYSTEM WITH WARNING INDICATOR		



Prepared for:
 JEFF MORRIS
 ALEXIS FIRE EQUIPMENT CO
 (BB)
 109 EAST BROADWAY
 ALEXIS, IL 61412
 Phone: 309-937-3800

Prepared by:
 Duane Schaefer
 TRANSSHICAGO TRUCK
 GROUP
 776 N. YORK STREET
 ELMHURST, IL 60126
 Phone: 815-509-9079

Description	Weight Front	Weight Rear
SELF CANCELING TURN SIGNAL SWITCH WITH DIMMER, HEADLAMP FLASH, WASH/WIPE/INTERMITTENT		
INTEGRAL ELECTRONIC TURN SIGNAL FLASHER WITH 40 AMP (20 AMP PER SIDE) TRAILER LAMP CAPACITY		

Design

TWO COLOR CUSTOM PAINT

Color

CAB COLOR A: L3781EY VIPER RED ELITE EY
 CAB COLOR B: L5460EY PLATINUM PEARL METALLIC ELITE EY
 CHASSIS PAINT: N2648EA CANDY APPLE RED ELITE SS
 NO CAB/BODY EXTERIOR DECALS
 STANDARD E COAT/UNDERCOATING

Extended Front Axle Coverage

AXLE: DETROIT FRONT ONLY: HD MODERATE 5 YEARS/100,000 MILES/161,000 KM EXTENDED AXLE COVERAGE

Certification / Compliance

U.S. FMVSS CERTIFICATION, EXCEPT SALES CABS AND GLIDER KITS

Secondary Factory Options

CORPORATE PDI CENTER IN-SERVICE ONLY
 JACKSHAFT ASSEMBLIES ARE FOR TEMPORARY USE AND SHOULD ONLY BE USED FOR SHIPPING TO THE CUSTOMER/BODY BUILDER

TOTAL VEHICLE SUMMARY

Weight Summary

	Weight Front	Weight Rear	Total Weight
Factory Weight ⁺	8391 lbs	5076 lbs	13467 lbs
Total Weight⁺	8391 lbs	5076 lbs	13467 lbs

Application Version 11.9.805
 Harwington CT MY25 M2112
 ChecCam L9 RC...



07/17/2024 8:16 PM

Page 17 of 24

Prepared for:
JEFF MORRIS
ALEXIS FIRE EQUIPMENT CO
(BB)
109 EAST BROADWAY
ALEXIS, IL 61412
Phone: 309-937-3800

Prepared by:
Duane Schaefer
TRANSCHICAGO TRUCK
GROUP
776 N. YORK STREET
ELMHURST, IL 60126
Phone: 815-509-9079

Extended Warranty

CUM 2017 L9: HD1 MD DTY 5 YEARS / 100,000 MILES / 161,000 KM
EXTENDED WARRANTY. FEX APPLIES

CUM 2017 L9: AT3 MD DTY 5 YEARS / 100,000 MILES / 161,000 KM
AFTERTREATMENT. FEX APPLIES

TC4: US HD STANDARD/MODERATE VOCATIONAL 7 YEARS/100,000
MILES/161,000 KM EXTENDED TRUCK COVERAGE

AXLE: NON-DETROIT SINGLE REAR ONLY: HD MODERATE 5
YEARS/100,000 MILES/161,000 KM EXTENDED COVERAGE

TOWING: 1 YEAR/UNLIMITED MILES/KM EXTENDED TOWING
COVERAGE \$1200 CAP FEX APPLIES

(+) Weights shown are estimates only.

If weight is critical, contact Customer Application Engineering.

(***) All cost increases for major components (Engines, Transmissions, Axles, Front and Rear Tires) and government mandated requirements, tariffs, and raw material surcharges will be passed through and added to factory invoices.



Prepared for:
 JEFF MORRIS
 ALEXIS FIRE EQUIPMENT CO
 (BB)
 109 EAST BROADWAY
 ALEXIS, IL 61412
 Phone: 309-937-3800

Prepared by:
 Duane Schaefer
 TRANSCHICAGO TRUCK
 GROUP
 776 N. YORK STREET
 ELMHURST, IL 60126
 Phone: 815-509-9079

D I M E N S I O N S

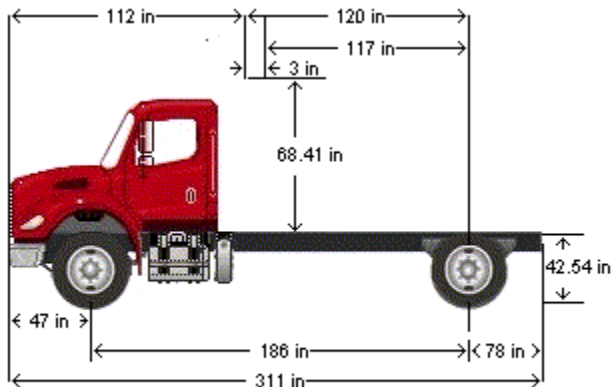

VEHICLE SPECIFICATIONS SUMMARY - DIMENSIONS

Model	M2112
Wheelbase (545)	4725MM (186 INCH) WHEELBASE
Rear Frame Overhang (552)	1975MM (78 INCH) REAR FRAME OVERHANG
Fifth Wheel (578)	NO FIFTH WHEEL
Mounting Location (577)	NO FIFTH WHEEL LOCATION
Maximum Forward Position (in)	0
Maximum Rearward Position (in)	0
Amount of Slide Travel (in)	0
Slide Increment (in)	0
Desired Slide Position (in)	0.0
Cab Size (829)	112 INCH BBC FLAT ROOF ALUMINUM CONVENTIONAL CAB
Sleeper (682)	NO SLEEPER BOX/SLEEPERCAB
Exhaust System (016)	RH OUTBOARD UNDER STEP MOUNTED HORIZONTAL AFTERTREATMENT SYSTEM ASSEMBLY WITH RH HORIZONTAL TAILPIPE EXITING FORWARD OF REAR TIRES



Prepared for:
 JEFF MORRIS
 ALEXIS FIRE EQUIPMENT CO
 (BB)
 109 EAST BROADWAY
 ALEXIS, IL 61412
 Phone: 309-937-3800

Prepared by:
 Duane Schaefer
 TRANSCHICAGO TRUCK
 GROUP
 776 N. YORK STREET
 ELMHURST, IL 60126
 Phone: 815-509-9079

TABLE SUMMARY - DIMENSIONS

Dimensions	Inches
Bumper to Back of Cab (BBC)	112.4
Bumper to Centerline of Front Axle (BA)	46.9
Front Axle to Back of Cab (AC)	65.6
Min. Cab to Body Clearance (CB)	3.0
Back of Cab to Centerline of Rear Axle(s) (CA)	120.5
Effective Back of Cab to Centerline of Rear Axle(s) (Effective CA)	117.5
Back of Cab Protrusions (Exhaust/Intake) (CP)	2.0
Back of Cab Protrusions (Side Extenders/Trim Tab) (CP)	0.0
Back of Cab Protrusions (CNG Tank)	0.0
Back of Cab Clearance (CL)	3.0
Back of Cab to End of Frame	198.3
Cab Height (CH)	68.4
Wheelbase (WB)	186.0
Frame Overhang (OH)	77.8
Overall Frame Length	293.9
Overall Length (OAL)	310.7
Rear Axle Spacing	0.0
Unladen Frame Height at Centerline of Rear Axle	42.5

Performance calculations are estimates only. If performance calculations are critical, please contact Customer Application Engineering.



Prepared for:
 JEFF MORRIS
 ALEXIS FIRE EQUIPMENT CO
 (BB)
 109 EAST BROADWAY
 ALEXIS, IL 61412
 Phone: 309-937-3800

Prepared by:
 Duane Schaefer
 TRANSCHICAGO TRUCK
 GROUP
 776 N. YORK STREET
 ELMHURST, IL 60126
 Phone: 815-509-9079

G V W R

VEHICLE SPECIFICATIONS SUMMARY - GVWR

Model M2112
 Cab Size (829)..... 112 INCH BBC FLAT ROOF ALUMINUM CONVENTIONAL CAB
 Expected Front Axle(s) Load (lbs)..... 16000.0
 Expected Pusher Axle(s) Load (lbs)..... 0.0
 Expected Rear Axle(s) Load (lbs)..... 31000.0
 Expected Tag Axle(s) Load (lbs)..... 0.0
 Expected GVW (lbs)..... 47000
 Expected GCW (lbs)..... 0.0
 Front Axle (400)..... DETROIT DA-F-16.0-5 16,000# FL1 71.0 KPI/3.74 DROP SINGLE FRONT AXLE
 Front Suspension (620)..... 16,000# FLAT LEAF FRONT SUSPENSION
 Front Hubs (418)..... CONMET PRESET PLUS PREMIUM IRON FRONT HUBS
 Front Disc Wheels (502)..... ALCOA ULTRA ONE 89U64X 22.5X9.00 10-HUB PILOT 5.99 INSET ALUMINUM FRONT WHEELS
 Front Tires (093)..... MICHELIN XZU-S2 315/80R22.5 20 PLY RADIAL FRONT TIRES
 Front Brakes (402)..... MERITOR 16.5X6 Q+ CAST SPIDER CAM FRONT BRAKES, DOUBLE ANCHOR, FABRICATED SHOES
 Steering Gear (536)..... TRW TAS-85 POWER STEERING
 Rear Axle (420)..... CUMMINS-MERITOR RS-30-185 31,000# U-SERIES FIRE/EMERGENCY SERVICE SINGLE REAR AXLE
 Rear Suspension (622)..... 31,000# FLAT LEAF SPRING REAR SUSPENSION WITH HELPER AND RADIUS ROD FOR FIRE/EMERGENCY SERVICE
 Rear Hubs (450)..... WEBB IRON REAR HUBS
 Rear Disc Wheels (505)..... ALCOA ULTRA ONE 89U64X 22.5X9.00 10-HUB PILOT 5.99 INSET ALUMINUM REAR WHEELS
 Rear Tires (094)..... MICHELIN X WORKS XDY 315/80R22.5 20 PLY RADIAL REAR TIRES
 Rear Brakes (423)..... MERITOR 16.5X7 P CAST SPIDER CAM REAR BRAKES, DOUBLE ANCHOR, CAST SHOES
 Pusher / Tag Axle (443)..... NO PUSHER OR TAG AXLE
 Pusher / Tag Suspension (626)..... NO PUSHER OR TAG SUSPENSION
 Pusher / Tag Hubs (449)..... NO PUSHER OR TAG HUBS
 Dead/Pusher/Tag Disc Wheels (509)..... NO PUSHER/TAG DISC WHEELS
 Pusher / Tag Tires (095)..... NO PUSHER/TAG TIRES
 Pusher / Tag Brakes (456)..... NO PUSHER/TAG BRAKES



Prepared for:
 JEFF MORRIS
 ALEXIS FIRE EQUIPMENT CO
 (BB)
 109 EAST BROADWAY
 ALEXIS, IL 61412
 Phone: 309-937-3800

Prepared by:
 Duane Schaefer
 TRANSCHICAGO TRUCK
 GROUP
 776 N. YORK STREET
 ELMHURST, IL 60126
 Phone: 815-509-9079

TABLE SUMMARY - GVWR

	Front	Rear
Axle Component Weight Ratings		
Axles	16000	31000
Suspension	16000	31000
Hubs	23000	31000
Brakes	20000	32500
Wheels	20000	40000
Tires	20000	33080
Power Steering	18000	N/A
GAWR (per axle)	16000	31000
GAWR (per axle system)	16000	31000
Expected Load (per axle system)	16000	31000
GVWR due to Frame	90000	
GVWR due to Transmission	300000	
Vehicle GVWR Summary		
Calculated GVWR	47000	
Expected GVWR	47000	
<i>All weights displayed in pounds</i>		

Performance calculations are estimates only. If performance calculations are critical, please contact Customer Application Engineering.



Prepared for:
 JEFF MORRIS
 ALEXIS FIRE EQUIPMENT CO
 (BB)
 109 EAST BROADWAY
 ALEXIS, IL 61412
 Phone: 309-937-3800

Prepared by:
 Duane Schaefer
 TRANSCHICAGO TRUCK
 GROUP
 776 N. YORK STREET
 ELMHURST, IL 60126
 Phone: 815-509-9079

F R A M E R B M

VEHICLE SPECIFICATIONS SUMMARY - FRAME RBM

Wheelbase (545)4725MM (186 INCH) WHEELBASE
 Frame Rails (546)..... 7/16X3-9/16X11-1/8 INCH STEEL FRAME (11.11MMX282.6MM/0.437X11.13 INCH) 120KSI(546)
 Yield Strength (psi) 120000
 Section Modulus (per rail) (cu in) 21.6
 RBM (per rail) (lbf-in) 2592000
 Inner Frame Reinforcement (547)..... 1/4 INCH (6.35MM) C-CHANNEL INNER FRAME REINFORCEMENT
 Outer Frame Reinforcement (548)..... NO OUTER FRAME REINFORCEMENT

TABLE SUMMARY - FRAME RBM

Item	Description / Value
Wheelbase	4725MM (186 INCH) WHEELBASE
Frame	7/16X3-9/16X11-1/8 INCH STEEL FRAME (11.11MMX282.6MM/0.437X11.13 INCH) 120KSI
Inner Frame Reinforcement	1/4 INCH (6.35MM) C-CHANNEL INNER FRAME REINFORCEMENT
Outer Frame Reinforcement	NO OUTER FRAME REINFORCEMENT
Yield Strength (psi)	120000
Section Modulus - per rail (cu. in.)	31.00
Frame RBM - per rail (lbf-in)	3715200

Performance calculations are estimates only. If performance calculations are critical, please contact Customer Application Engineering.



Prepared for:
 JEFF MORRIS
 ALEXIS FIRE EQUIPMENT CO
 (BB)
 109 EAST BROADWAY
 ALEXIS, IL 61412
 Phone: 309-937-3800

Prepared by:
 Duane Schaefer
 TRANSCHICAGO TRUCK
 GROUP
 776 N. YORK STREET
 ELMHURST, IL 60126
 Phone: 815-509-9079

TURNING RADIUS

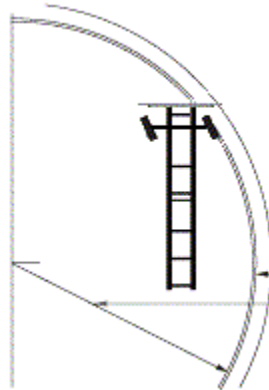

Turning radius graphic and data provided strictly for comparisons between model configurations. Weather, road surfaces, and tire treads affect the results. It is strongly suggested that actual vehicles be measured before constructing any roads/driveways using this information. For specific figures regarding your configuration, please contact your CAE representative.

	Dimensions	Tolerance
Wall to Wall Diameter (ft)	58.0	+/- 3.0
Curb to Curb Diameter (ft)	55.9	+/- 3.0
Turning Radius (ft)	27.4	+/- 1.5

VEHICLE SPECIFICATIONS SUMMARY - TURNING RADIUS

Model	M2112
Cab Size (829).....	112 INCH BBC FLAT ROOF ALUMINUM CONVENTIONAL CAB
Wheelbase (545)	4725MM (186 INCH) WHEELBASE
Front Tires (093).....	MICHELIN XZU-S2 315/80R22.5 20 PLY RADIAL FRONT TIRES
Width (in)	12.5
Front Axle (400).....	DETROIT DA-F-16.0-5 16,000# FL1 71.0 KPI/3.74 DROP SINGLE FRONT AXLE
Kingpin Intersection (in)	71
Bumper (556)	THREE-PIECE 14 INCH CHROME STEEL BUMPER WITH COLLAPSIBLE ENDS AND LH WING CUTOUT FOR FEDERAL MS100/ES100/ES100C SPEAKER
Width (in)	92.5
Bumper Miter to Front Axle (in)	27.56
Primary Steering Location (003)	LH PRIMARY STEERING LOCATION
Steering Gear (536).....	TRW TAS-85 POWER STEERING
Dual Steering Gear	NONE
Ram.....	NONE
Rear Axle (420)	CUMMINS-MERITOR RS-30-185 31,000# U-SERIES FIRE/EMERGENCY SERVICE SINGLE REAR AXLE
Axle Spacing (624)	NO AXLE SPACING

Performance calculations are estimates only. If performance calculations are critical, please contact Customer Application Engineering.

