

3000-GALLON TANKER DEMO 2333

DAKOTA FIRE PROTECTION DISTRICT / DAKOTA, ILLINOIS



ALEXIS



THANK YOU TO THE DAKOTA FIRE PROTECTION DISTRICT FOR THE PURCHASE OF THIS UNIT.



TECHNICAL SPECIFICATIONS

- Freightliner M2 106 Tandem 2-Door Chassis
- Cummins L9, 350-HP Diesel Engine
- Allison 3000 EVS Automatic Transmission
- Heavy Duty Stainless Steel Body and sub-frame
- ROM Roll Up Doors
- 3000-Gallon Poly Tank
- One (1) 4" Fireman's Friend Tank fill, rear
- One (1) Newton 10" square manual swivel dump with 36" extension
- Darley PSM 1250-GPM PTO Pump
- Left side intermediate pump operator's panel
- Three (3) 2 1/2" Discharges, two (2) left side and one (1) right side
- One (1) 3" Discharge, right side
- One (1) 1 1/2" and one (1) 2 1/2" Mattydale Preconnects, behind cab
- One (1) 2 1/2" Gated Suction, left side
- Two (2) Dual bottle Air bottle compartments, one (1) each side wheel well
- Three (3) Walk-away air pack brackets, left side compartment
- Roll out drop down folding tank storage, left side compartment op
- Suction hose storage, right side compartment top under tank "T"
- Ladder brackets, right side
- One (1) Hose storage box, rear tailstep area
- Manual battery recharge shoreline connection
- Air coupling for external air compressor
- One (1) Audiovox Back-up Camera system with 7" color monitor
- Code-3 Electronic Siren with 100-watt Code-3 speaker
- Code-3 LED Scene Light Package
- Code-3 LED Warning Light Package
- Diamond Grade Chevron pattern striping, rear
- 10' 2" Overall height
- 31' 6" Overall length
- 236" Wheelbase
- 170.45" Cab to Axle
- 16,000 FAWR
- 40,000 RAWR
- 56,000 GVWR



To view more photos and download spec sheet, please visit us at AlexisFire.com.

CUSTOMER APPROVAL SIGNATURE: _____ DATE: _____

ALEXIS-2333

IN THE EVENT THERE ARE DISCREPANCIES BETWEEN THE DRAWING AND THE SPECIFICATIONS, THE SPECIFICATIONS SHALL PREVAIL.

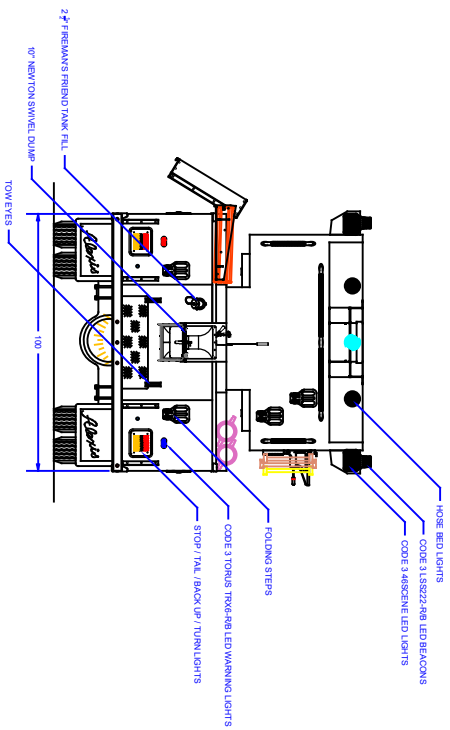
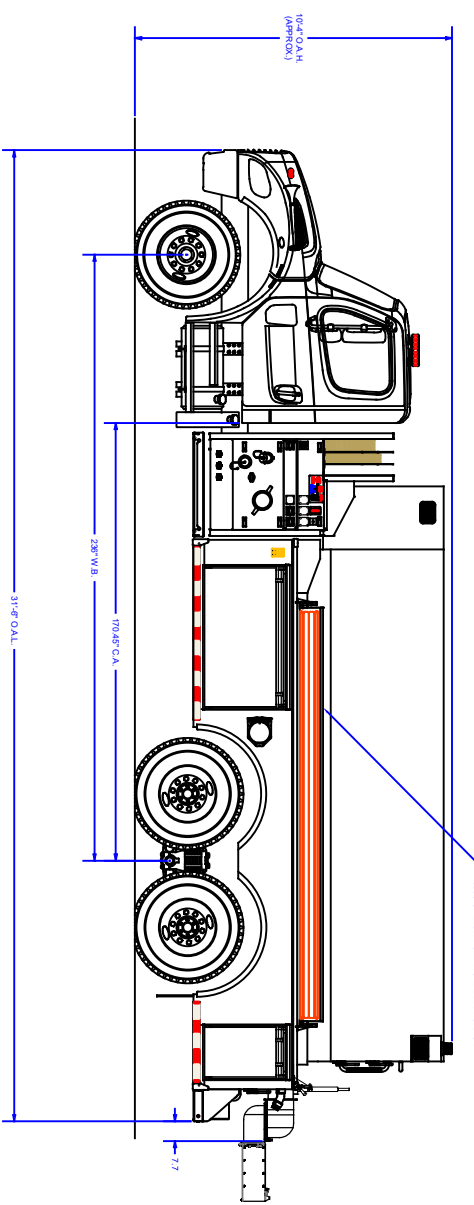
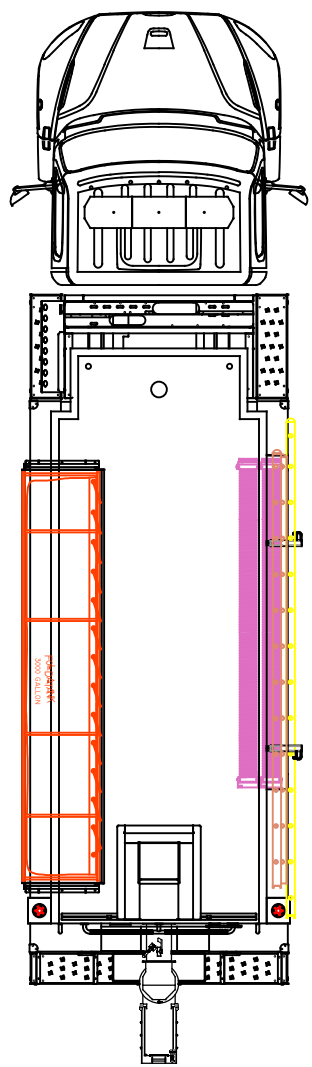
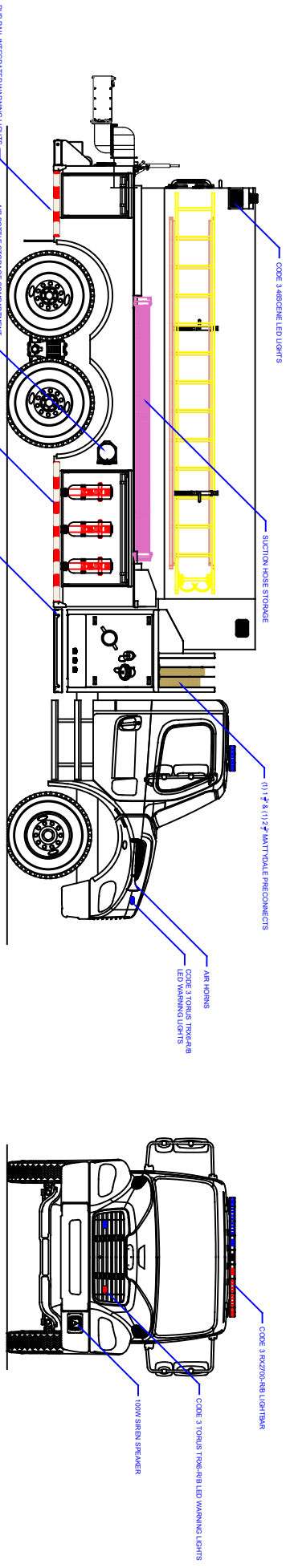

COMPARTMENT DIMENSIONS

Control Unit:	Apparatus Type:	COMP #
Control Location: Under Tank	Tanker	LI & RI
Pump Drive: DTG	Chassis: Freightliner 2-Door	L2 & R2
Pump Make: Darby	Tank Capacity: 3000	
Pump Model: PSM		
Pump GPM: 1500	Material: Stainless Steel	

UNLESS OTHERWISE SPECIFIED, DIMENSIONS ARE IN INCHES. TOLERANCES ARE AS SHOWN. ALL DIMENSIONS ARE TO CENTERLINE UNLESS NOTED OTHERWISE.

ALEXIS FIRE EQUIPMENT CO.
 P.O. BOX 569, ALEXIS, ILLINOIS 61812

WETSIDE TANKER
 DAKOTA FIRE PROT DIST
 DAKOTA, IL

DATE: 6/26/17
 DRAWN BY: M.TINKHAM
 CHECKED BY: D
 CONTACT # 2333

SIZE SCALE: 1/2" = 1'
 SHEET: 1 OF 2