

2000-GALLON TANKER

CHELSEA AREA FIRE AUTHORITY / CHELSEA, MICHIGAN



ALEXIS

THANK YOU TO THE CHELSEA AREA FIRE AUTHORITY FOR THE PURCHASE OF THIS UNIT.



TECHNICAL SPECIFICATIONS

- Freightliner 114SD 2-Door Chassis
- Cummins L9, 450-HP Diesel Engine
- Allison 3000 EVS Automatic Transmission
- Heavy Duty Stainless steel Body and Sub-Frame
- ROM Roll Up Doors
- 2000-Gallon Wet side Poly Tank
- One (1) Newton 10" square manual swivel dump with 36" extension
- One (1) 2 1/2" Fire Programs tank fill, rear
- Darley PSM 1500-GPM Pump
- Left side Intermediate pump panel with slide out platform
- Three (3) 2 1/2" Discharges, two (2) left side and one (1) right side
- One (1) 3" Discharge with 5" Storz, right side
- One (1) 2 1/2" Gated Suction, left side
- One (1) 2 1/2" and one (1) 1 1/2" Mattydale Preconnect
- One (1) Electric Booster Reel with 150' of 1" hose, ahead of hosebed
- Ladder, Suction hose and Pike pole storage, right side
- Custom Roll out Drop down Tool storage, left side compartment top
- Manual shoreline receptacle
- Air coupling for external compressor
- Floor Mounted console for emergency switches
- Whelen Electronic Siren with 100-watt Whelen speaker
- Whelen LED and FireTech LED Scene Light Package
- Whelen LED Warning Light Package
- Diamond Grade Chevron striping, rear
- 10' Overall height
- 26' 6" Overall length
- 200" Wheelbase
- 134.4" Cab to Base
- 14,600 FAWR
- 30,000 RAWR
- 44,600 GVWR



To view more photos and download spec sheet, please visit us at AlexisFire.com.

CUSTOMER APPROVAL SIGNATURE: _____ DATE: _____

AFE-2358

IN THE EVENT THERE ARE DISCREPANCIES BETWEEN THE DRAWING AND THE SPECIFICATIONS, THE SPECIFICATIONS SHALL PREVAIL.

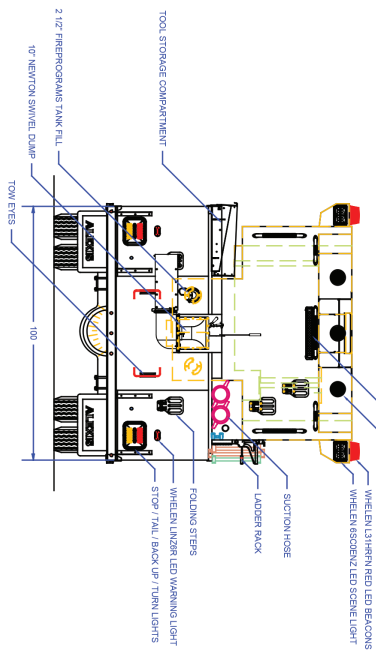
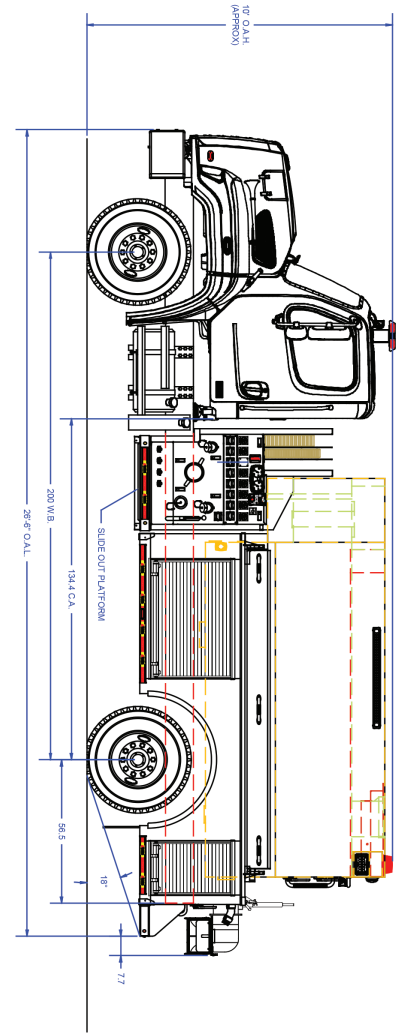
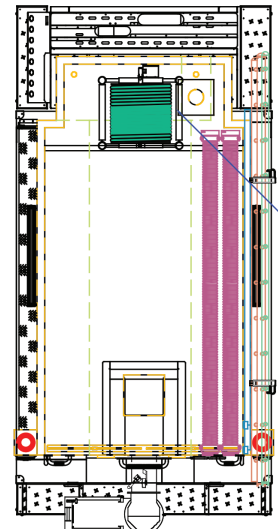
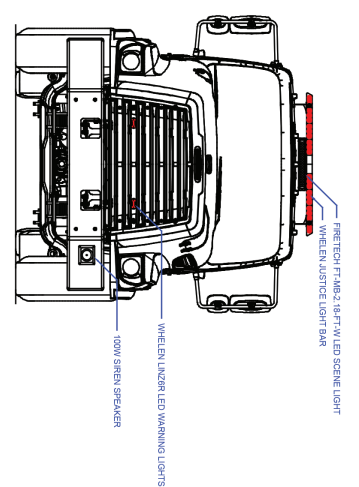
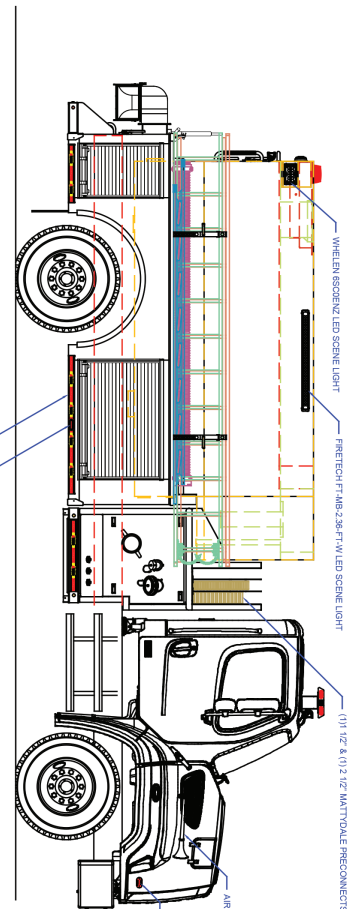

COMPARTMENT DIMENSIONS

DOOR OPENING SIZES
45" WIDE X 27" HIGH X 26" DEEP
19" WIDE X 27" HIGH X 26" DEEP

ALEXIS FIRE EQUIPMENT CO.
 P.O. BOX 549, ALEXIS, ILLINOIS 62412

CHELSEA FIRE AUTHORITY
 CHELSEA, MI

PROJECT: T-197
 DRAWING: T-197-11
 CONTRACT #: 2358

REVISION HISTORY	CONTROL INFO.	APPARATUS TYPE	TANKER
DESCRIPTION	CONTROL LOCATION	CHASSIS	FRIGHTLINER 2-DOOR
DATE	PUMP DRIVE	TANK CAPACITY	2000
DRAWN	PUMP MODEL	MATERIAL	STAINLESS STEEL
PUMP OPER.			

8 7 6 5 4 3 2 1

A B C D