



STANDARD FEATURES:

- Heavy Duty 14 gauge 304, #4 finish stainless steel body
- Stainless Steel Sub frame
- ROM Roll Up Doors
- 650, 750, 1000, or 1250 Gallon Poly Tank
- Darley PSM, 1250-GPM Pump
- Top Mount or Side Control Pump operator's panel
- Two (2) 2 ½" Discharges, one (1) each side
- Two (2) 3" Discharges, one (1) rear and one (1) deck gun over pump
- Two (2) 1 ½" Mattydale preconnect module, behind chassis cab
- One (1) 2 ½" Gated Suction, left side
- Ladder storage through tank with rear access
- Hypalon Hose bed and preconnect covers
- One (1) AFE stainless steel top access ladder, rear mounted
- Whelen or Code 3 LED Warning Light Package
- Whelen or Code 3 Electronic Siren with 100-watt speaker
- Diamond Grade Chevron pattern striping, rear

AVAILABLE OPTIONS:

- 1500 GPM Pump
- 1250 GPM PTO Pump
- Heated Pump Enclosure
- Foam System
- Front Suction
- Right Side LDH Discharge
- Bumper Preconnect
- Booster Reel
- Heavy Duty .190" Aluminum Body with Galvanized Steel Subframe
- Front Turret (available on PTO Application or Mobile Pump option)
- Wheel Well Air Bottle Compartments
- Shelves and trays in compartments
- HIVIZ LED Scene Lighting
- 120 Volt Electrical System (Hydraulic or Portable Generator)
- Varying Preconnect Options
- Painted Roll Up Doors

SIDE CONTROL COMMERCIAL CHASSIS

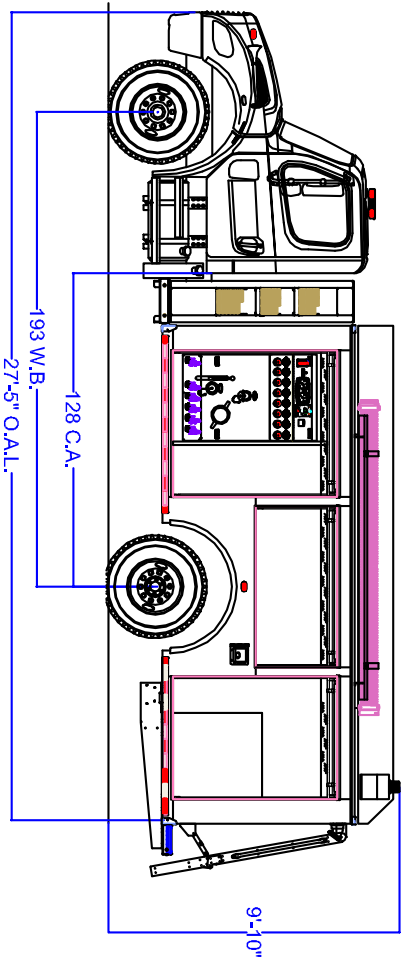

SIDE CONTROL CUSTOM CHASSIS

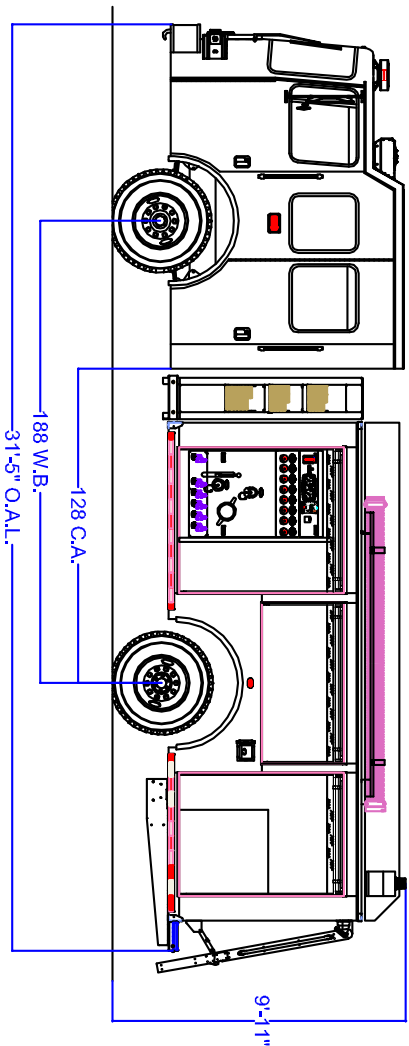

TOP CONTROL COMMERCIAL CHASSIS

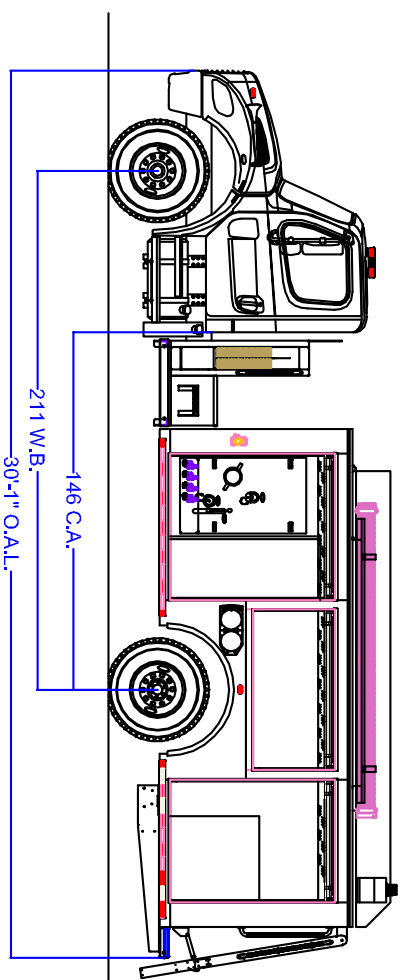

TOP CONTROL CUSTOM CHASSIS

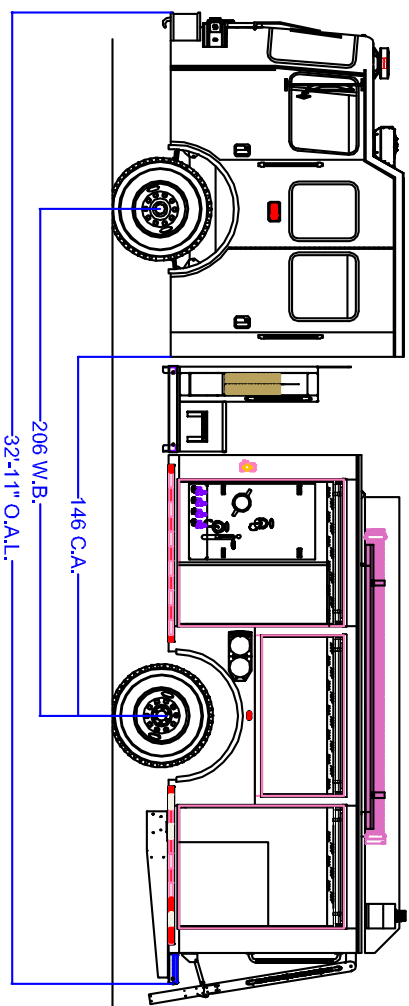

1000 GALLON

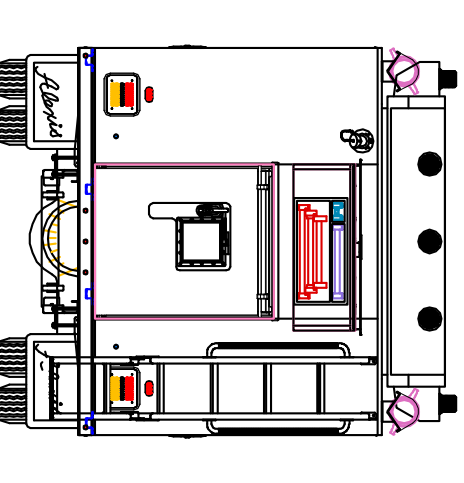

650/750 GALLON

