

12' RESPONSE ONE #5785

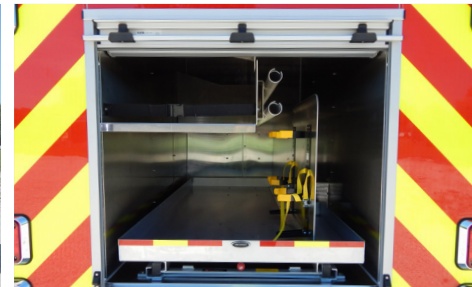

TECHNICAL SPECIFICATIONS

- Ford F-550 4x4 Super Duty Crew Cab Chassis
- 6.7L Power Stroke V8 Turbo Diesel Engine
- TorqShift 10-Speed Automatic Transmission
- Heavy Duty Stainless Steel Body and Sub-Frame
- Four (4) Person Cab
- One (1) Back-Up Camera with Ford Dash Mounted Display
- ROM Painted Roll-Up Doors
- One (1) 500# Roll-Out Tray with Shelf, L1 Compartment
- One (1) 500# Roll-Out Tray, R1 Compartment
- Transverse Stokes and Backboard Storage Rack, L1/R1 Compartments
- One Hinged Aluminum Tool Board, R2 Compartment
- One (1) 1000# Roll-Out Tray with Two Walk-Away Air Pack Brackets, Rear Compartment
- Little Giant Ladder Storage Shelf, Rear Compartment
- Two (2) Single Bottle Wheel Well Storage Compartments, Right Side
- Progressive Dynamics Battery Charger with Kussmaul 120V 20A Super Auto Eject, Left Side Above Rear Wheel Well
- Whelen Warning Light Package
- Akron Telescopic Lights, One (1) Each side Ahead of the Body
- FireTech Scene Lights
- Rub Rails with Ground and Warning Lights
- Two (2) Air Horns, Bumper Mounted
- Whelen Electric Siren & 100 W Speaker
- Two (2) Federal Signal Rumbler Speakers
- Front, Side Tie-Off Points, and Rear Receivers with Winch Wiring
- Diamond Grade Chevron Striping, Rear
- 8' 5" Overall Height
- 25' 5" Overall Length
- 7,500 FAWR
- 14,700 RAWR
- 19,500 GVWR



CUSTOMER APPROVAL SIGNATURE: _____ DATE: _____

ATHENS-0006

IN THE EVENT THERE ARE DISCREPANCIES BETWEEN THE DRAWING AND THE SPECIFICATIONS THE SPECIFICATIONS SHALL PREVAIL.

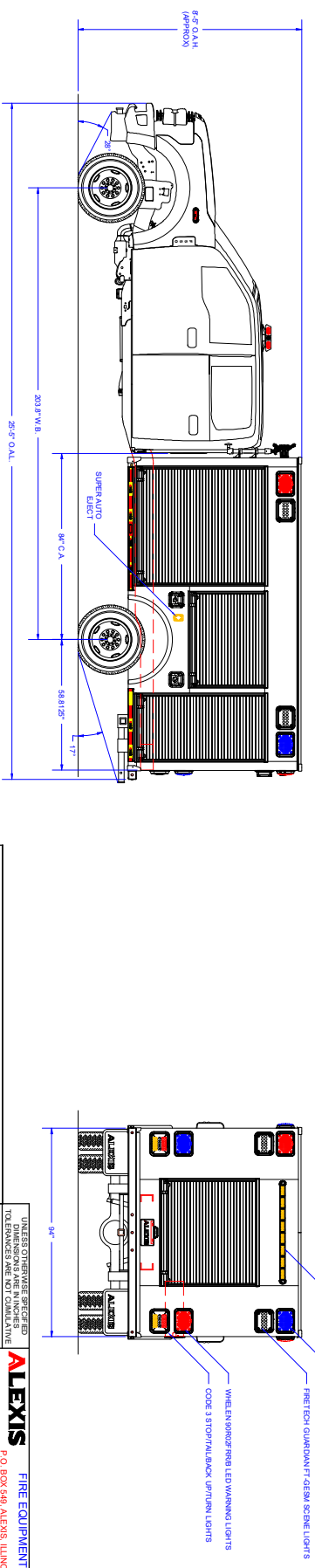
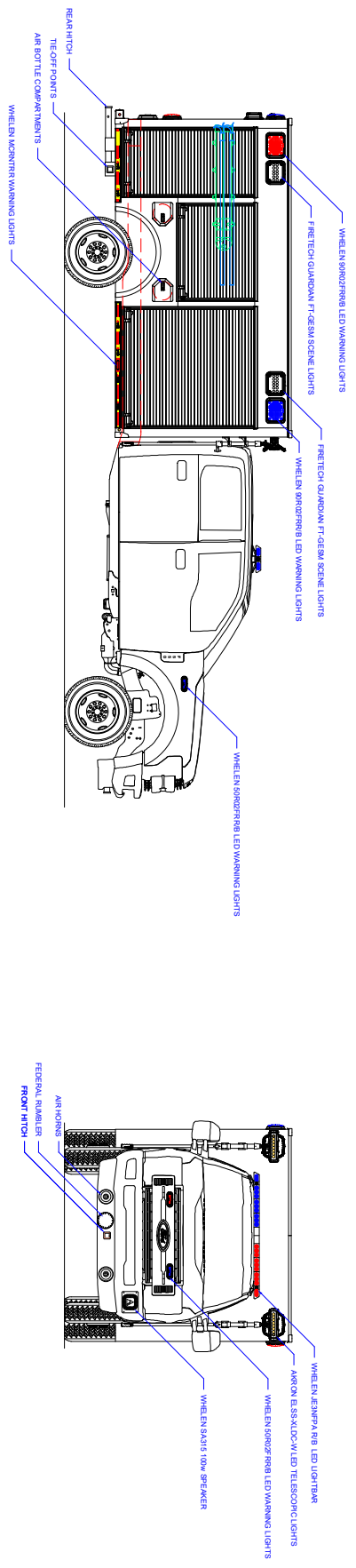

COMPARTMENT DIMENSIONS

COMP #	DOOR OPENING SIZES
L1 & R1	51" WIDE X 53" HIGH X 21" TRANSVERSE DEEP
L2 & R2	41" WIDE X 29" HIGH X 21" DEEP
L3 & R3	28" WIDE X 53" HIGH X 21" DEEP
REAR	46" WIDE X 39" HIGH X 80" DEEP

REVISION HISTORY

REV	DESCRIPTION	DATE	DMN	Pump Info.
05	SALES UPDATE	10/1/21	JMH	Control Location: None
04	SALES UPDATE	9/27/21	JMH	Pump Driver: None
03	SALES UPDATE	9/22/21	JMH	Chassis: Ford 4-Door
02	SALES UPDATE	5/19/21	JMH	Tank Capacity: None
01	SALES UPDATE	5/17/21	JMH	Pump Model: None

UNLESS OTHERWISE SPECIFIED DIMENSIONS ARE IN MILLIMETERS (IN CHINESE DIMENSIONS ARE NOT QUANTIFIABLE)

ALEXIS FIRE EQUIPMENT CO.
P.O. BOX 549, ATHENS, ILLINOIS 61412

12" RESPONSE 1
ATHENS, ILL.