

PICK-UP BRUSH TRUCK

ALTONA FIRE PROTECTION DISTRICT / ALTONA, ILLINOIS



ALEXIS

THANK YOU TO THE ALTONA FIRE PROTECTION DISTRICT FOR THE PURCHASE OF THIS UNIT.



TECHNICAL SPECIFICATIONS

- Ford F-350 4x4 SRW 2-door pick-up 8-foot box
- Ford 6.2L V8, 385-HP Gasoline Engine
- Ford Torqshift 6-speed Automatic Transmission
- Headache rack front of pick-up box
- 300-Gallon Poly skid Tank
- Darley 1 ½ AGE Pump with 20-HP Honda Gasoline Engine
- One (1) 1 ½" Discharge, rear
- One (1) 1" Booster line with 10-ft of hose
- One (1) Akron front bumper Turret remote controlled from the cab
- Ranch Hand Legend replacement bumper with brush guard and receiver
- One (1) Warn Zeon 10, 10,000-lb winch
- Trident "Foamate" Class A Around the pump Foam system with pick-up tube
- One (1) Hannay Electric booster reel with 150-ft of 1" hose
- One (1) Hose tray, right side of tank
- Code-3 Electronic Siren with Code-3 100-watt speaker
- One (1) Golight spotlight with in-cab remote control
- One (1) Fire Research swivel LED Work Light
- Code-3 LED Warning Light Package
- Diamond Grade Chevron striping, rear
- 142" Wheelbase
- 5,600 FAWR
- 7,230 RAWR
- 11,300 GVWR

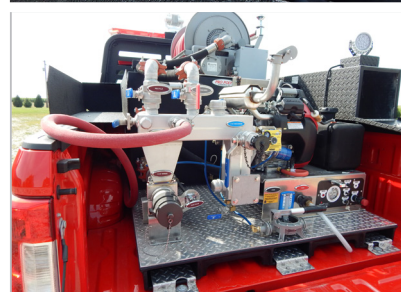
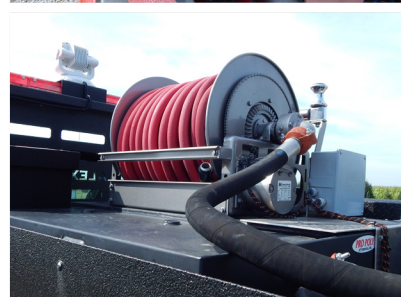

To view more photos and download spec sheet, please visit us at AlexisFire.com.

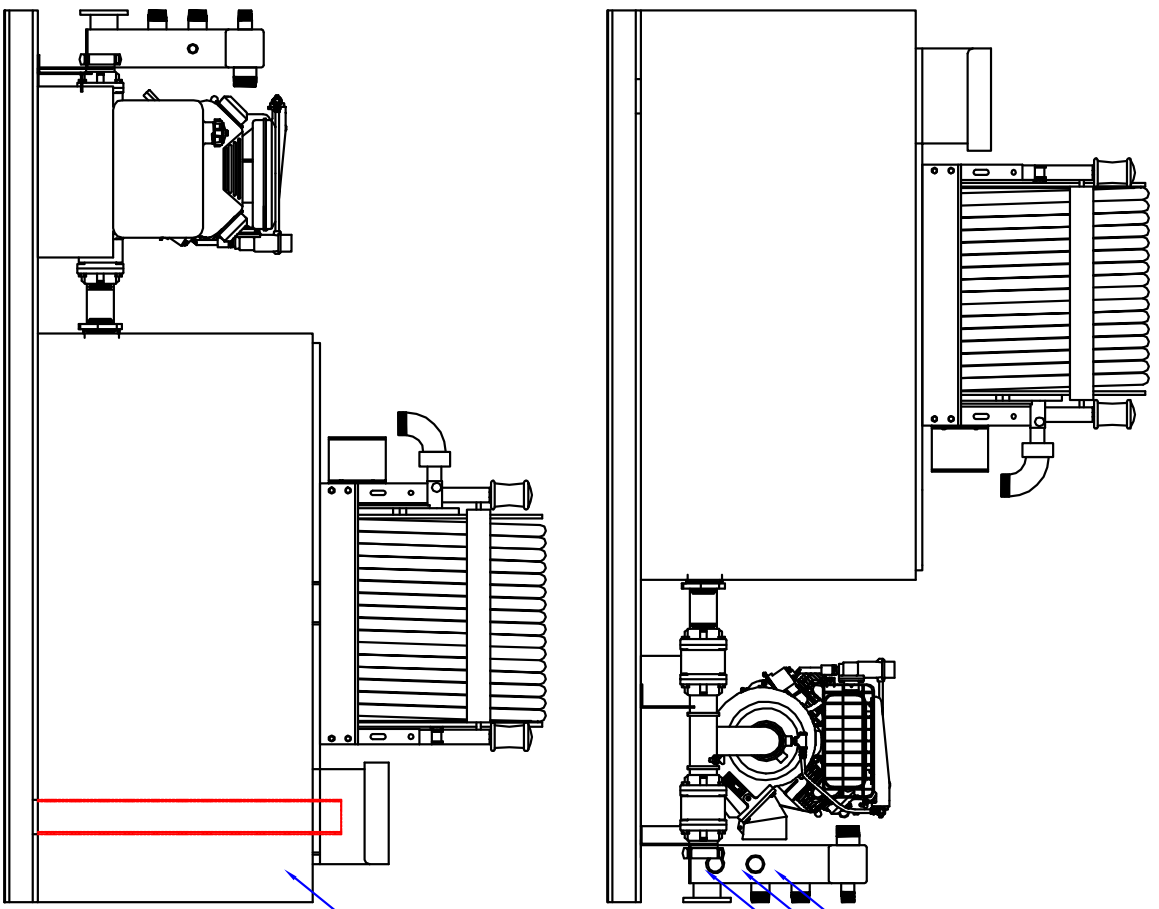

300 GALLON
SKID TANK

1.5" DISCHARGE
1" BOOSTER LINE
2.5" TANK VALVE

DARLEY 1.5 AGP
PUMP

HANNAY BOOSTER REEL
150' OF 1" HOSE

HONDA 20HP
ENGINE

