

BRUSH TRUCK

HENRY FIRE PROTECTION DISTRICT / HENRY, IL



ALEXIS



THANK YOU TO HENRY FIRE PROTECTION DISTRICT FOR THE PURCHASE OF THIS UNIT.



TECHNICAL SPECIFICATIONS

- Ford F-550 XL, 4x4 4-Door DRW Chassis
- Ford Power Stroke 6.7L V8, 330-HP Diesel Engine
- Ford TorqShift 6-speed Automatic Transmission
- Heavy Duty 3/16" Aluminum Body
- Two (2) compartments with two (2) lift up doors each
- Backboard storage compartment for two (2) backboards, left side with rear access
- Warn stainless steel brush guard with wrap around and front receiver
- Reese Type rear trailer hitch/winch receiver with electrical connections
- 400-Gallon Poly Skid Tank
- Darley 11/2 AGE Pump with 20-HP Honda gasoline engine
- Two (2) 1" booster lines with 10-ft of hose each
- One (1) 2 1/2" rear Discharge
- Two (2) Electrically controlled spray booms, front bumper
- One (1) 2 1/2" Gated Suction, rear
- One (1) Hannay Electric Booster Reel with 150-ft of 1" hose
- Progressive Dynamics on-board battery charger
- Kussmaul Super Auto Eject 120-volt shoreline connection
- Floor mounted console for electrical switches with map/binder storage, cab
- One (1) Gooseneck style map light, cab
- Whelen Electronic Dual Siren with two (2) 100-watt Whelen speakers
- Two (2) Whelen LED Scene Lights, rear
- Two (2) Akron Extenda-Lite 12-volt Revel LED Telescopic Scene lights
- Whelen LED Warning Light Package
- Chevron pattern striping, rear
- 8' 6" Overall height
- 22' 9" Overall length
- 179.8" Wheelbase
- 60" Cab to Axle

- 7,500 FAWR
- 14,706 RAWR
- 19,500 GVWR

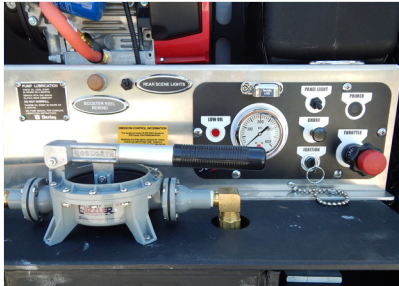

To view more photos and download flyer, please visit us at AlexisFire.com.

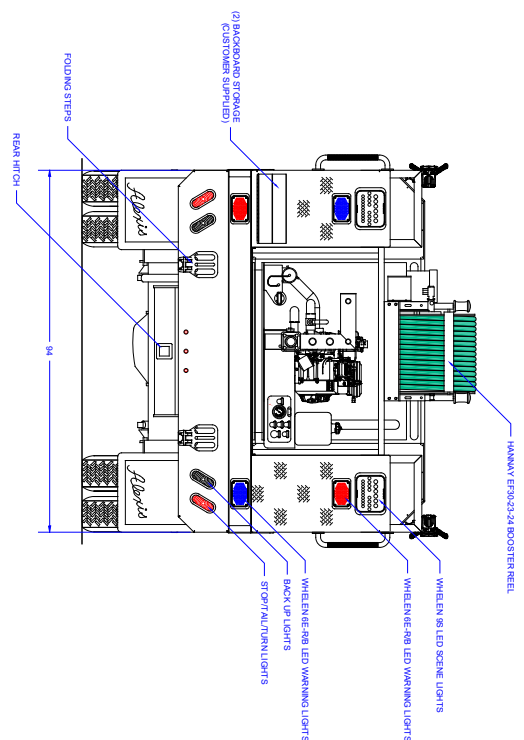
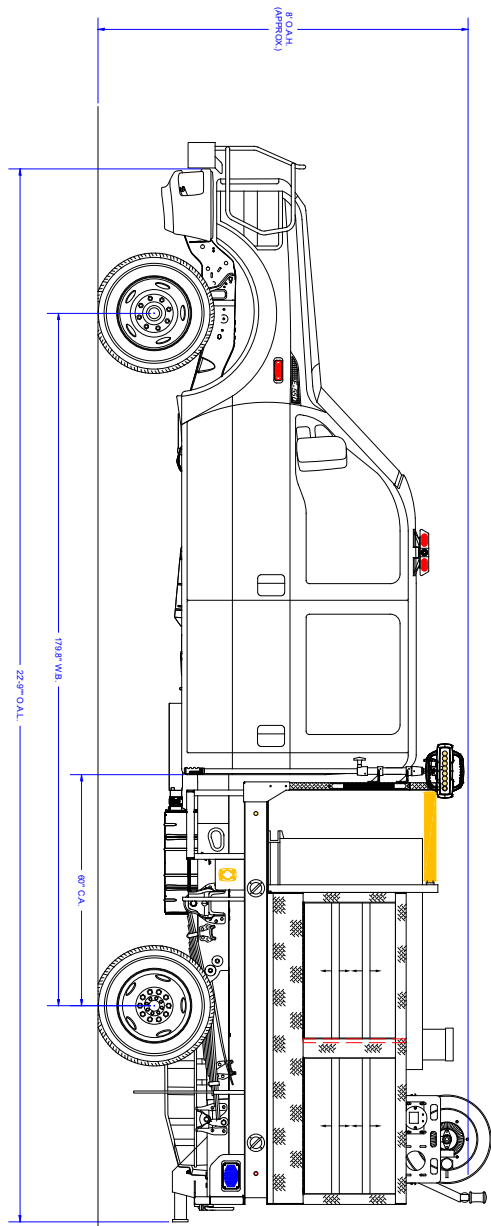
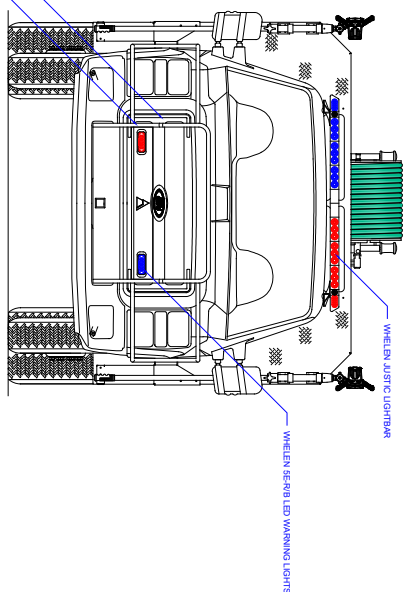
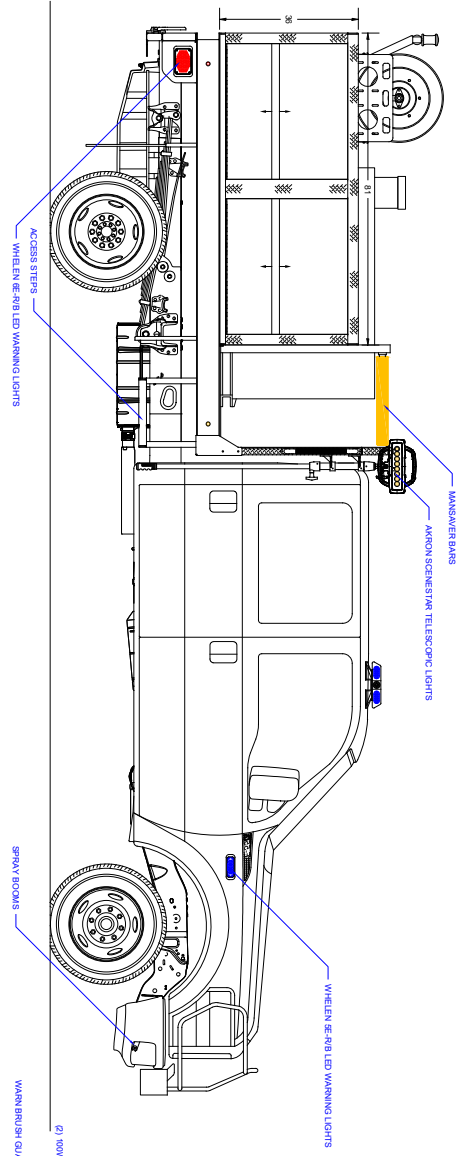

REVISION HISTORY	
REV 02	DESCRIPTION: PRELIMINARY CHANGES
REV 01	DESCRIPTION: SHEET UPDATES

Pump Info:	
Control Location:	Rear
Pump Drive:	
Chassis:	Ford 4-Door
Tank Capacity:	400
Pump Model:	
Pump GPM:	
Material:	Aluminum

COMPARTMENT DIMENSIONS	
Apparatus Type:	Brush Truck
COMP #	L1 & L2
DOOR OPENING SIZES	R1 & R2
35" WIDE X 23" HIGH X 17" DEEP	
35" WIDE X 31" HIGH X 17" DEEP	

UNLESS OTHERWISE SPECIFIED
DIMENSIONS ARE IN INCHES AND DECIMAL FRACTIONS ARE NOT CUMULATIVE
TOLERANCES ARE NOT CUMULATIVE
FRACTIONAL: 1/16 METRIC: 1.0mm

Henry FIRE EQUIPMENT CO.
P.O. BOX 560 ALENIS, ILLINOIS 61412

BRUSH TRUCK
HENRY FIRE PROTECTION DISTRICT
HENRY, ILLINOIS

DATE: 7/18/16
DRAWN BY: MTINKHAM
CHECKED BY: SK856
SHEET 1 OF 2

CUSTOMER APPROVAL SIGNATURE: _____ DATE: _____

IN THE EVENT THERE ARE DISCREPANCIES BETWEEN THE DRAWING AND THE SPECIFICATIONS, THE SPECIFICATIONS SHALL PREVAIL.

HENRY-002