

# 3000-GALLON TANKER

PLEASANT PLAINS TOWNSHIP FIRE DEPARTMENT / BALDWIN, MICHIGAN



# ALEXIS



THANK YOU TO THE PLEASANT PLAINS TOWNSHIP FIRE DEPARTMENT FOR THE PURCHASE OF THIS UNIT.



## TECHNICAL SPECIFICATIONS

- International HV607 Tandem 2-Door Chassis
- Cummins L9, 450-HP Diesel Engine
- Allison 3000 EVS Automatic Transmission
- Heavy Duty Stainless Steel Body and Sub-frame
- ROM Roll Up Doors
- 3000-Gallon Wet side Poly Tank
- One (1) 2 1/2" Fire Programs Tank fill, rear
- One (1) Newtom 10" square manual swivel dump with 36" extension
- Darley PSM 1500-GPM PTO Pump
- Left side intermediate pump operator's panel
- Three (3) 2 1/2" Discharges, two (2) left side and one (1) right side
- One (1) 3" Discharge with 5" Storz, right side
- One (1) 1 1/2" and one (1) 2 1/2" Mattydale Preconnects, behind cab
- One (1) 2 1/2" Gated Suction, left side
- Folding Tank storage, right side compartment top
- Suction hose storage, left side compartment top
- Manual battery recharge shoreline connection
- Air coupling for external air compressor
- Floor mounted console for emergency switches, cab
- Whelen Electronic Siren with 100-watt Whelen speaker
- Whelen LED Scene Light Package, one (1) light each side and two (2) rear
- Whelen LED Warning Light Package
- Diamond Grade Chevron pattern striping, rear
- 10' 3" Overall height
- 31' 6" Overall length
- 238" Wheelbase
- 170.9" Cab to Axle
- 16,000 FAWR
- 40,000 RAWR
- 56,000 GVWR



To view more photos and download spec sheet, please visit us at [AlexisFire.com](http://AlexisFire.com).

CUSTOMER APPROVAL SIGNATURE: \_\_\_\_\_ DATE: \_\_\_\_\_

IN THE EVENT THERE ARE DISCREPANCIES BETWEEN THE DRAWING AND THE SPECIFICATIONS, THE SPECIFICATIONS SHALL PREVAIL.

**AFF-2371**

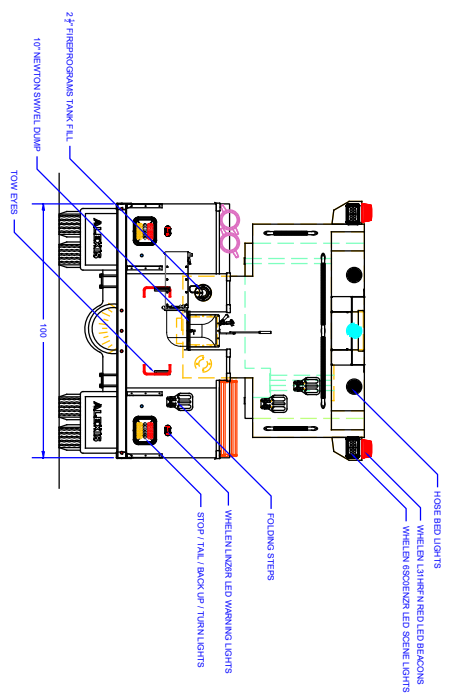
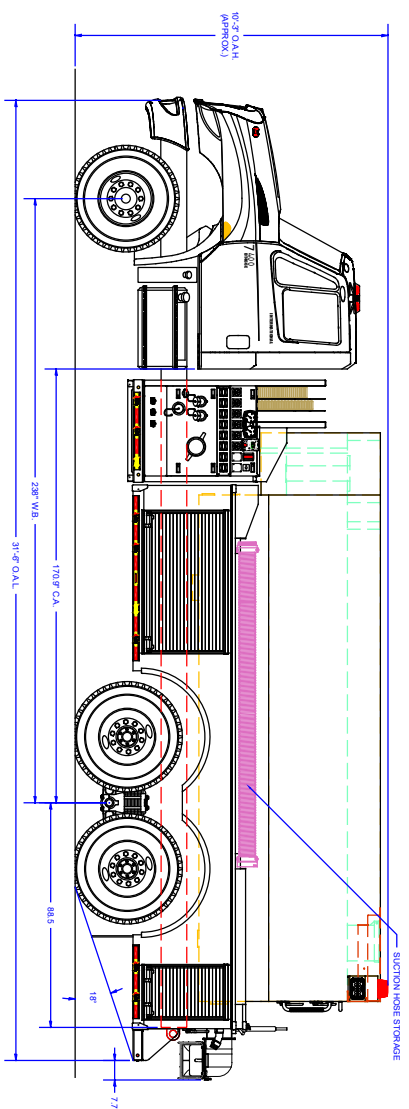
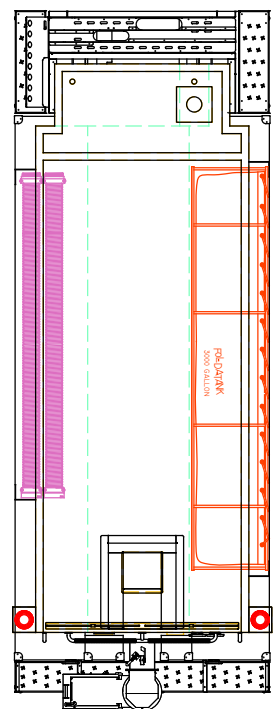
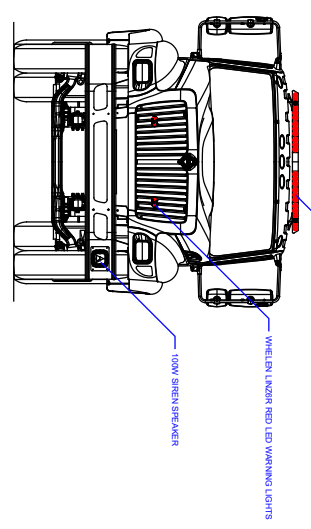
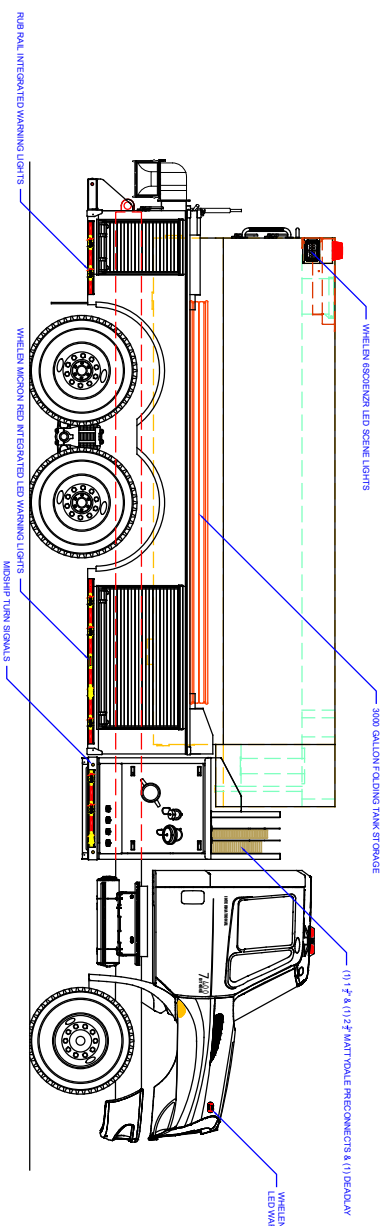

**COMPARTMENT DIMENSIONS**

Pump Info:		Control Location: Under Tank		Apparatus Type: Tanker	
Pump Drive: Split Shaft		Tank Capacity: 3000		Chassis: Navistar 2-Door	
Pump Make: Darley		Pump Model: PSM		Material: Stainless Steel	
Pump GPH: 1500		COMP #		DOOR OPENING SIZES	
REV		DESCRIPTION		DATE	
7		REVISON HISTORY		8/28/18	
6		DRAWING		M. BLISH	
5		MATERIAL		CONTRACT #	
4		L2 & L2		2371	
3		54" WIDE X 27" HIGH X 28" DEEP		SHEET #	
2		17" WIDE X 27" HIGH X 20" DEEP		1 OF 2	
1		100"		2371	

**ALEXIS FIRE EQUIPMENT CO.**  
 P.O. BOX 569, ALEXIS, ILLINOIS 62412

**ALEXIS FIRE EQUIPMENT**  
 ALEXIS, IL

**T-116**

UNLESS OTHERWISE SPECIFIED  
 DIMENSIONS ARE IN INCHES  
 FRACTIONAL & TYPING METRIC 2.5 mm

The copyright of this drawing and design  
 and the right of reproduction here in, whole  
 or in part, is reserved by Alexis Fire Equipment  
 Company, Inc.