

10-FOOT RESPONSE ONE

KANE COUNTY OFFICE OF EMERGENCY MANAGEMENT / GENEVA, IL



ALEXIS



THANK YOU TO KANE COUNTY OFFICE OF EMERGENCY MANAGEMENT FOR THE PURCHASE OF THIS UNIT.



TECHNICAL SPECIFICATIONS

- Ford F-450 XL Super Cab 4x4 DRW Chassis
- Ford 6.8L V-10, 288-HP Gasoline Engine
- Ford TorqShift 6-speed Automatic Transmission
- Heavy Duty Stainless Steel Body and sub-frame
- ROM Painted Roll Up Doors
- Reese type rear trailer hitch with electrical connections
- 1000-lb rear roll out compartment tray
- Turtle Tile on shelves and/or trays in each compartment
- Floor mounted console for emergency switches, cab
- Progressive Dynamics on-board battery charger
- Kusmaul Super Auto Eject 120-volt shoreline connection
- Honda 5000-watt gasoline generator with 120-volt electrical system
- Command Light Knight light tower with six (6) FRC Spectra 220-watt LED lights
- Whelen Electronic Siren with 100-watt Whelen speaker
- Whelen LED Warning Light Package
- Chevron pattern striping, rear
- 8' 1" Overall height
- 22' 4" Overall length
- 168" Wheelbase
- 60" Cab to Axle
- 5,200 FAWR
- 12,880 RAWR
- 16,500 GVWR



To view more photos and download flyer, please visit us at AlexisFire.com.

CUSTOMER APPROVAL SIGNATURE: _____ DATE: _____

KANE CO-0003

IN THE EVENT THERE ARE DISCREPANCIES BETWEEN THE DRAWING AND THE SPECIFICATIONS, THE SPECIFICATIONS SHALL PREVAIL.

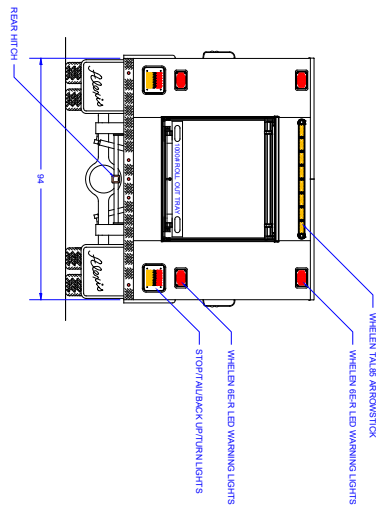
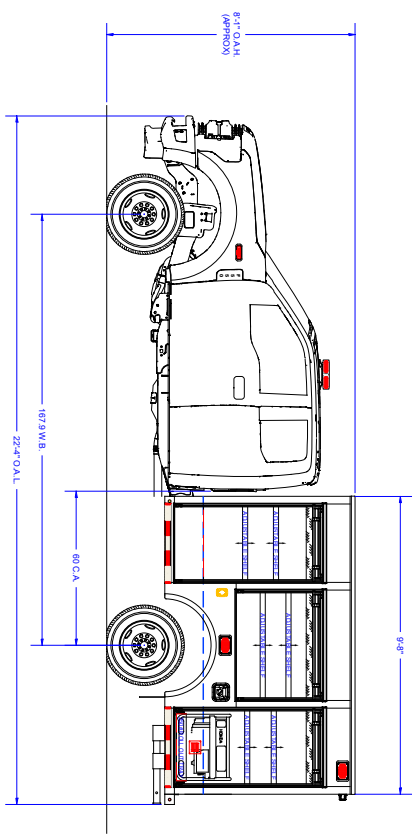
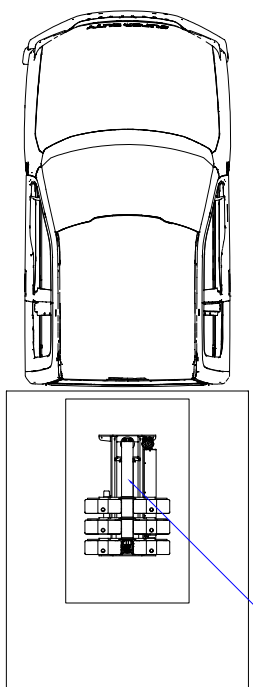
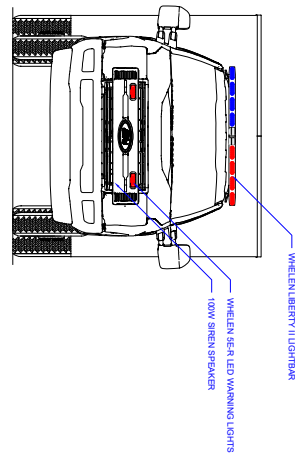
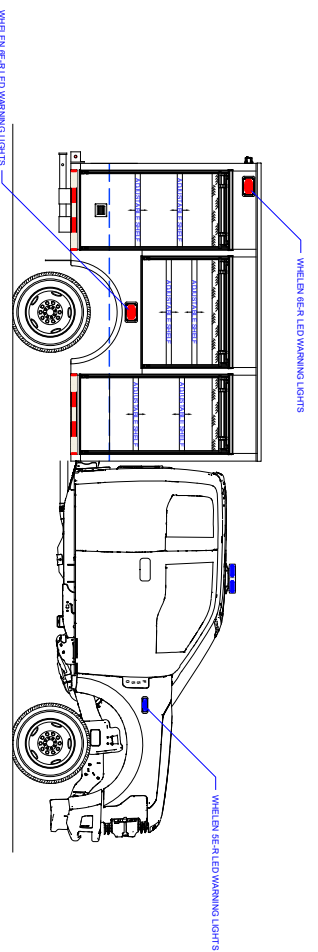

COMPARTMENT DIMENSIONS

COMP #	DOOR OPENING SIZES
L1 & R1	28" WIDE X 55" HIGH X 21" DEEP
L2 & R2	41" WIDE X 29" HIGH X 21" DEEP
L3 & R3	28" WIDE X 53" HIGH X 21" DEEP
REAR	46" WIDE X 39" HIGH X 50" DEEP

REV	DESCRIPTION	DATE	BY
02	SALES UPDATES	2/2/17	MCT
01	SALES UPDATES	12/31/17	MCT

Control Location	None
Pump Drive	None
Chassis	Navistar 2-Door
Tank Capacity	
Pump Model	None
Pump GPM	

Apparatus Type	Response 110' (60' C.A.)
Material	Stainless Steel

UNLESS OTHERWISE SPECIFIED, DIMENSIONS ARE IN INCHES (CONVERSIONS ARE NOT COMPLICATIVE)

FRSCTOOL 2.1.16 AMERIC 2.1.16

Firebits FIRE EQUIPMENT CO.
 P.O. BOX 568 ALEXIS, ILLINOIS 61412

RESPONSE ONE
 KANE COUNTY
 GENEVA, IL

SIZE SCALE: DWG/NO
 D 1/2" = 1'
 CONTRACT # 5760 SHEET 1 OF 2