

# 3000-GALLON PUMPER/TANKER

BRIMFIELD COMMUNITY FIRE DISTRICT / BRIMFIELD, IL



# ALEXIS



THANK YOU TO BRIMFIELD COMMUNITY FIRE DISTRICT FOR THE PURCHASE OF THIS UNIT.



## TECHNICAL SPECIFICATIONS

- Freightliner M2 106 2-Door Tandem Chassis
- Cummins ISL, 350-HP Diesel Engine
- Allison 3000 EVS Automatic Transmission
- Heavy Duty Stainless Steel Body
- ROM Roll Up Doors
- 3000-Gallon Wet Side Poly Tank
- One (1) 2 1/2" Fireman's Friend Tank fill, rear
- One (1) Newton 10" square manual swivel tank dump with 36" extension, rear
- Darley PSM, 1250-GPM Pump
- Pump Operator's panel under tank on left side
- Three (3) 2 1/2" Discharges, two (2) left side and one (1) right side
- One (1) 3" Discharge, right side
- One (1) 1 1/2" and one (1) 2 1/2" Mattydale Preconnects
- One (1) 2 1/2" Gated Suction, left side
- Folding Tank rack storage, top of compartments, right side
- Suction Hose storage tray, top of compartments, left side
- Floor mounted console for Emergency switches, cab
- Air coupling for external compressor
- Code 3 Electronic Siren with 100-watt Code 3 speaker
- Code 3 LED Scene Light Package
- Code 3 LED Warning Light Package
- Diamond Grade Chevron pattern striping, rear
- 9' 11" Overall height
- 33' 2" Overall length
- 248" Wheelbase
- 182.45" Cab to Axle
- 16,000 FAWR
- 40,000 RAWR
- 56,000 GVWR



To view more photos and download flyer, please visit us at [AlexisFire.com](http://AlexisFire.com).



8 7 6 5 4 3 2 1

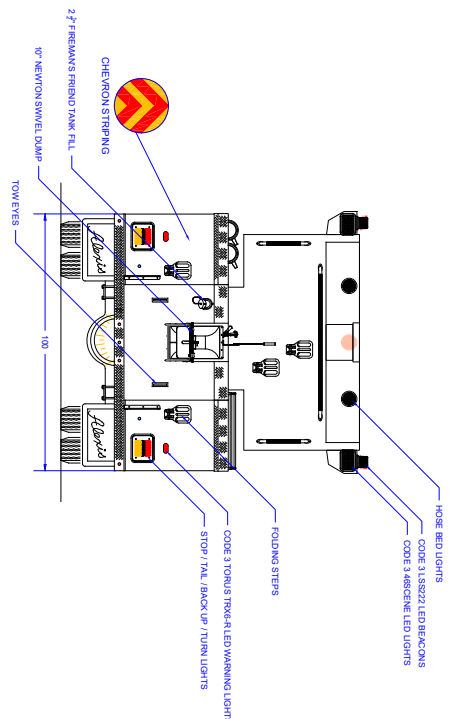
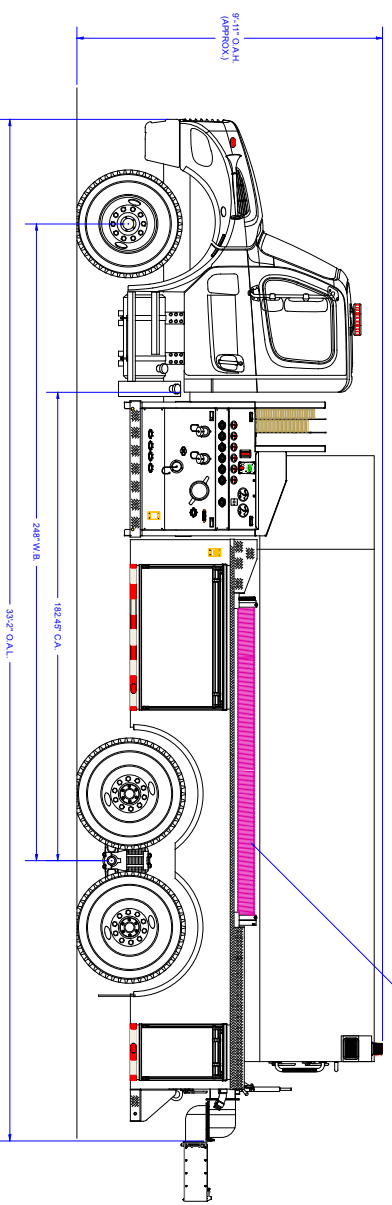
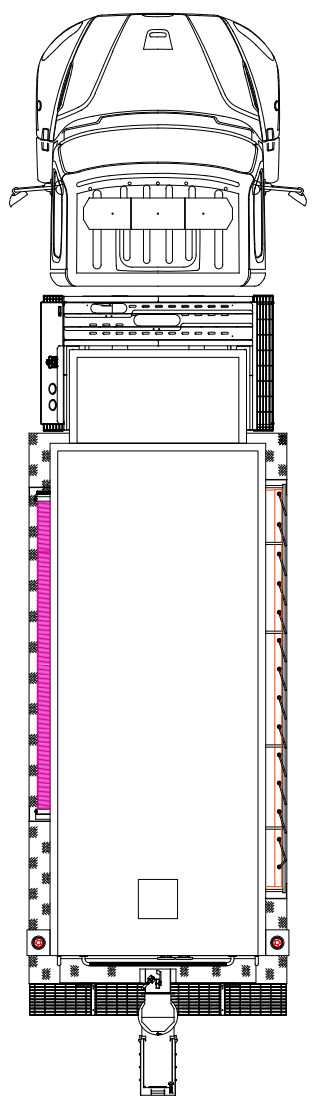
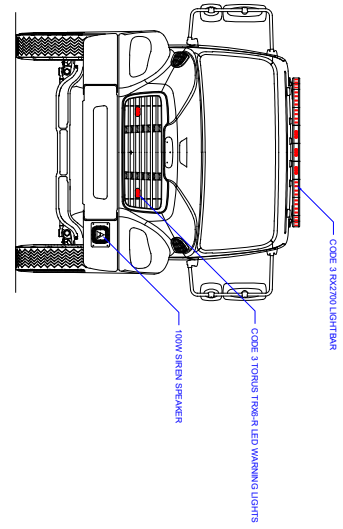
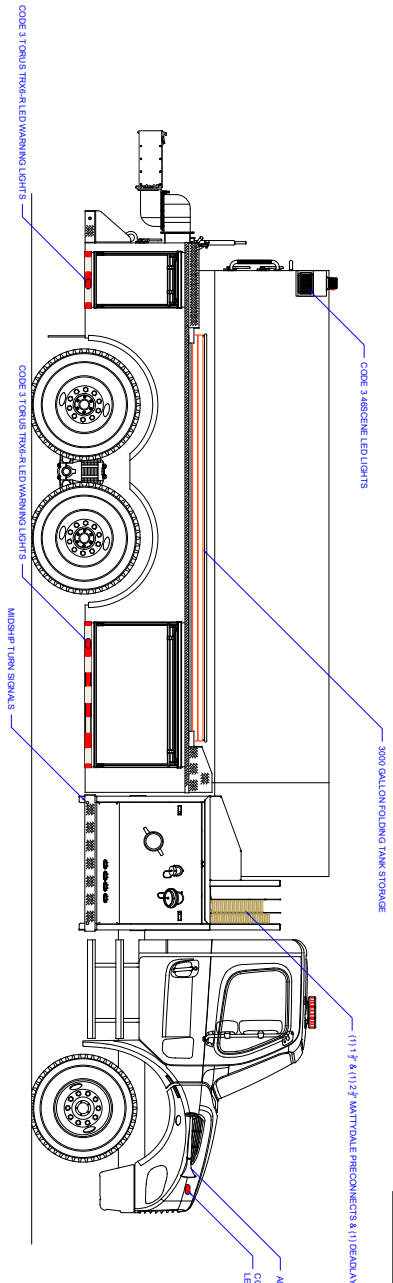

Pump Info:		Apparatus Type: Tanker
Control Location:	Under Tank	Chassis: Freightliner 2-Door
Pump Drive:	DTG	Tank Capacity: 3000
Pump Make:	Darby	
Pump Model:	PSM	
Pump GPM:	1250	

COMPARTMENT DIMENSIONS	
DOOR #	54" WIDE X 27" HIGH X 26" DEEP
LI & RI	19" WIDE X 27" HIGH X 26" DEEP
L2 & R2	

REV	DESCRIPTION	DATE	OWN	APP	MATERIAL
01	SALES INQUIRY	9/10/15	MLT	PMP	Stainless Steel

CUSTOMER APPROVAL SIGNATURE: \_\_\_\_\_ DATE: \_\_\_\_\_

IN THE EVENT THERE ARE DISCREPANCIES BETWEEN THE DRAWING AND THE SPECIFICATIONS, THE SPECIFICATIONS SHALL PREVAIL.

AFE-2279