

# 3000-GALLON TANKER



## ASHKUM TOWNSHIP FIRE PROTECTION DISTRICT ASHKUM, ILLINOIS

### TECHNICAL SPECS

- International 7500 2-Door Tandem Chassis
- MaxxForce 10, 350-HP Diesel Engine
- Allison 3000 EVS Automatic Transmission
- Heavy Duty 3/16" Aluminum Body
- ROM Roll Up Doors
- 3000-Gallon Wet side Poly Tank with 30-Gallon foam tank
- One (1) 10" Electric Newton swivel tank dump with 36" manual extension
- Two (2) 2 1/2" Fireman's Friend Tank fills, rear
- Waterous CXVK, 1000-GPM Pump
- Left side under tank pump operator's panel
- Two (2) 2 1/2" Discharges, left side
- One (1) 4" Discharge, right side
- One (1) 2 1/2" Gated Suction, left side
- One (1) 3" Discharge for Deck Gun
- Waterous Advantus 6 Foam system
- One (1) Akron FireFox front bumper turret with cab remote control
- Three (3) Mattydale Preconnects, two (2) 1 1/2" and one (1) 2 1/2", behind cab
- Kussmaul Air Eject, left side
- Folding tank storage rack for 3000-gallon tank, right side compartment top
- Suction hose storage tray, left side compartment top
- Ladder storage brackets, left side
- One (1) Audiovox back-up camera with 7" color monitor
- Federal Q2B mechanical siren, flush mounted front bumper
- Two (2) Air Horns, one (1) each side of hood
- Floor mounted console for emergency switches, cab
- Six (6) Federal GHSCENE lights, two (2) each side and two (2) rear
- Whelen LED Warning Light Package
- Chevron pattern striping, rear
- 9' 10" Overall height
- 30' 6" Overall length
- 221" Wheelbase
- 153.9" Cab to Axle
- 16,000 FAWR
- 40,000 RAWR
- 56,000 GVWR



To view more photos,  
visit [www.AlexisFire.com](http://www.AlexisFire.com)

WE WOULD LIKE TO THANK  
THE ASHKUM TOWNSHIP FIRE  
PROTECTION DISTRICT FOR  
THEIR BUSINESS.



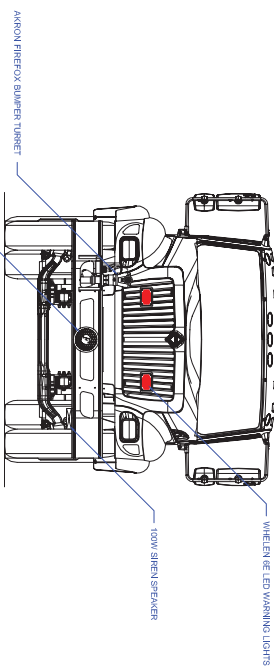
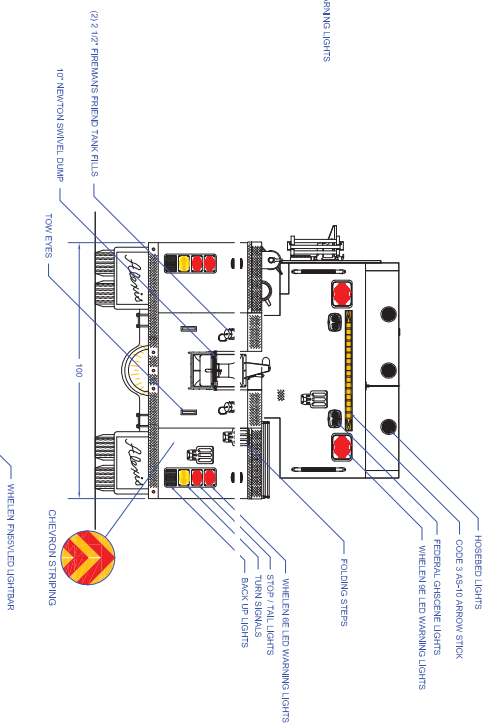
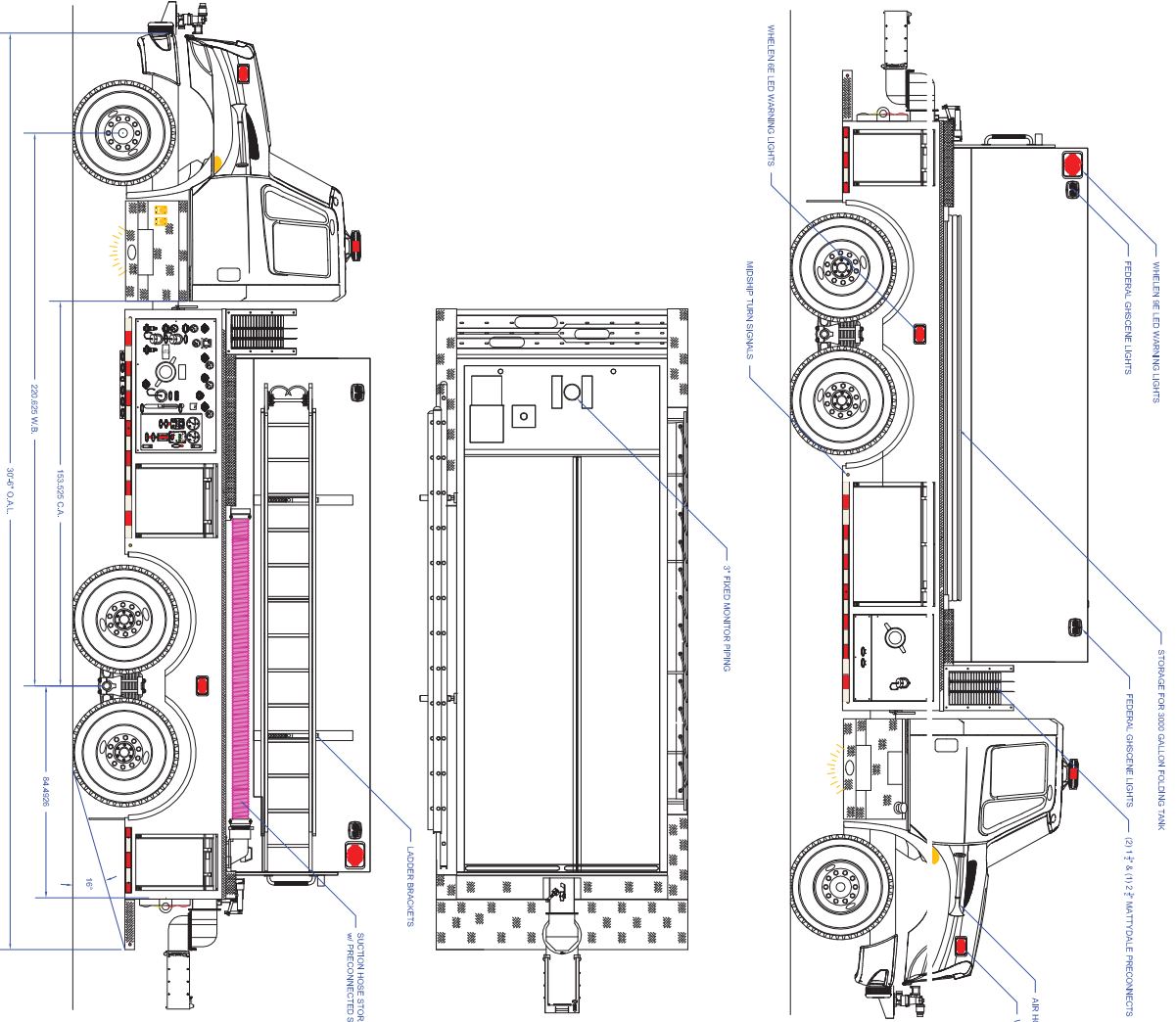

**COMPARTMENT DIMENSIONS**

| COMP #                              | DOOR OPENING SIZES             |
|-------------------------------------|--------------------------------|
| L1                                  | 27" WIDE X 27" HIGH X 26" DEEP |
| R1                                  | 45" WIDE X 27" HIGH X 26" DEEP |
| L2 & R2                             | 16" WIDE X 27" HIGH X 26" DEEP |
| UNLESS OTHERWISE SPECIFIED          |                                |
| DIMENSIONS ARE IN INCHES            |                                |
| TOLERANCES ARE AS FOLLOWS:          |                                |
| DIMENSIONAL ± 0.0625 ANGULAR ± 0.03 |                                |
| FUNCTIONAL ± 0.116 METRIC ± 0.6 mm  |                                |



**TANKER**  
 ASHKUM FIRE PROTECTION DIST.  
 ASHKUM, ILLINOIS

| REVISION HISTORY |                  |          | CUSTOMER APPROVAL SIGNATURE: |      |    | DATE: |  |  |
|------------------|------------------|----------|------------------------------|------|----|-------|--|--|
| REV              | DESCRIPTION      | DATE     | BY                           | DATE | BY |       |  |  |
| 01               | SALES UPDATES    | 10/30/21 | M.J.                         |      |    |       |  |  |
| 02               | CONTRACT UPDATES | 10/30/21 | REG                          |      |    |       |  |  |

| DATE | BY | DATE | BY |
|------|----|------|----|
|      |    |      |    |

| DESCRIPTION | DATE | BY |
|-------------|------|----|
| ASHKUM-0002 |      |    |

IN THE EVENT THERE ARE DISCREPANCIES BETWEEN THE DRAWING AND THE SPECIFICATIONS, THE SPECIFICATIONS SHALL PREVAIL.

| Pump Info:        |            | Apparatus Type: Tanker |                |
|-------------------|------------|------------------------|----------------|
| Control Location: | Under Tank | Chassis:               | Navigar 2-Door |
| Pump Drive:       | PTO        | Tank Capacity:         | 3000           |
| Pump Make:        | Various    | Material:              | Aluminum       |
| Pump Model:       | CX Series  |                        |                |
| Pump GPM:         | 1000       |                        |                |

| DATE | BY | DATE | BY |
|------|----|------|----|
|      |    |      |    |

| DATE | BY | DATE | BY |
|------|----|------|----|
|      |    |      |    |