

CUSTOMER APPROVAL SIGNATURE: \_\_\_\_\_ DATE: \_\_\_\_\_

DATE: \_\_\_\_\_

**ALEXIS D-0001**

IN THE EVENT THERE ARE DISCREPANCIES BETWEEN THE DRAWING AND THE SPECIFICATIONS, THE SPECIFICATIONS SHALL PREVAIL.

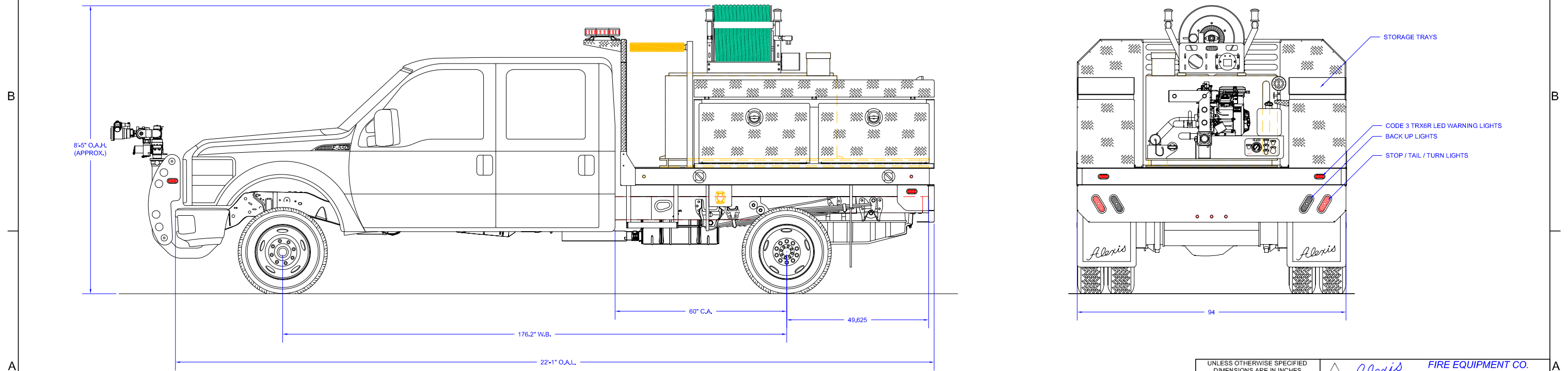
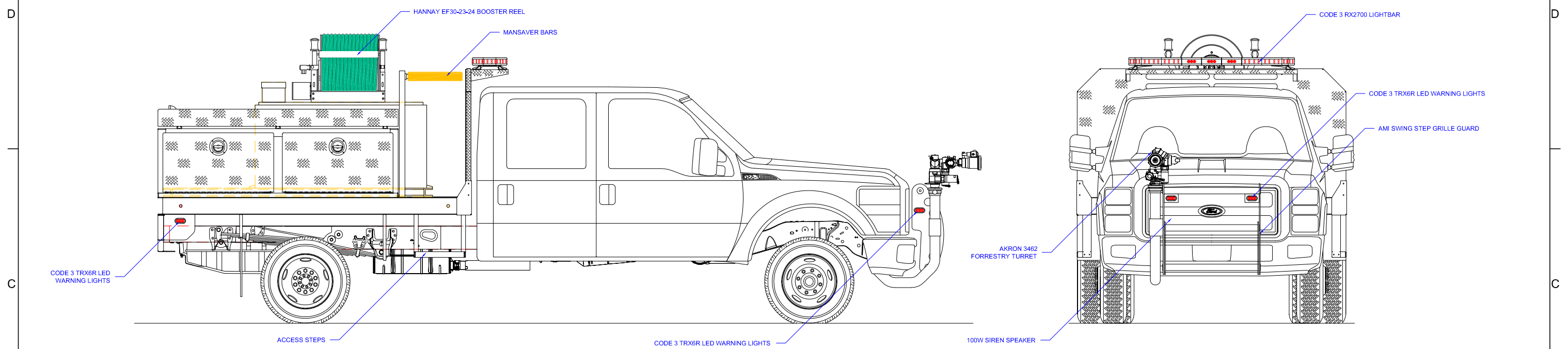

REVISION HISTORY			
REV	DESCRIPTION	DATE	DWN

<b>Pump Info:</b>		Apparatus Type: <b>Brush Truck</b>	
Control Location: <b>Rear</b>		Chassis: <b>Ford 4-Door</b>	
Pump Drive:		Tank Capacity: <b>300</b>	
Pump Make: <b>Skid - Gas</b>		Material: <b>Aluminum</b>	
Pump Model:			
Pump GPM:			

COMPARTMENT DIMENSIONS	
COMP #	DOOR OPENING SIZES
L1 & L2	36" WIDE X 19" HIGH X 17" DEEP
R1 & R2	36" WIDE X 19" HIGH X 17" DEEP

UNLESS OTHERWISE SPECIFIED DIMENSIONS ARE IN INCHES TOLERANCES ARE NOT CUMULATIVE  
 DECIMAL ± 0.062 ANGULAR ± 0.5°  
 FRACTIONAL ± 1/16 METRIC ± 1.6 mm

The copyright of this drawing and design and the right of reproduction there is vested in and belongs to Alexis Fire Equipment Co.

DRAWN: M.TINKHAM 3/2/16  
 MATERIAL: \_\_\_\_\_

**Alexis FIRE EQUIPMENT CO.**  
 P.O. BOX 549, ALEXIS, ILLINOIS 61412

**BRUSH TRUCK**  
 ALEXIS FIRE EQUIPMENT  
 ALEXIS, ILLINOIS

DWG NO: **SK-C25**

CONTRACT # SK821 SHEET 1 OF 2

CUSTOMER APPROVAL SIGNATURE:

DATE:

**ALEXIS D-0001**

IN THE EVENT THERE ARE DISCREPANCIES BETWEEN THE DRAWING AND THE SPECIFICATIONS, THE SPECIFICATIONS SHALL PREVAIL.

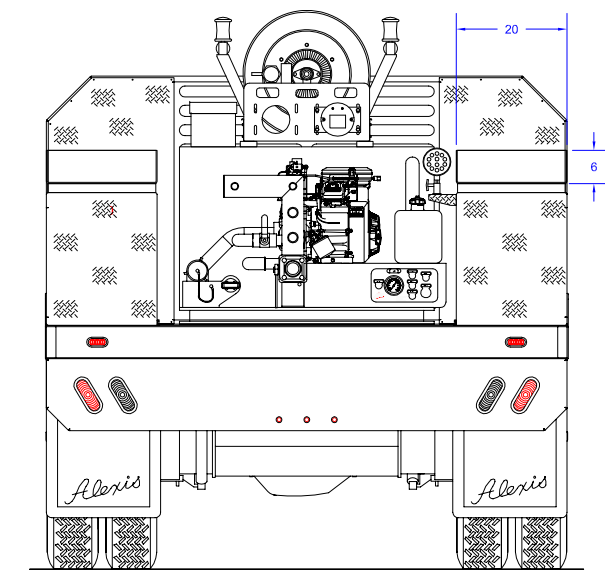
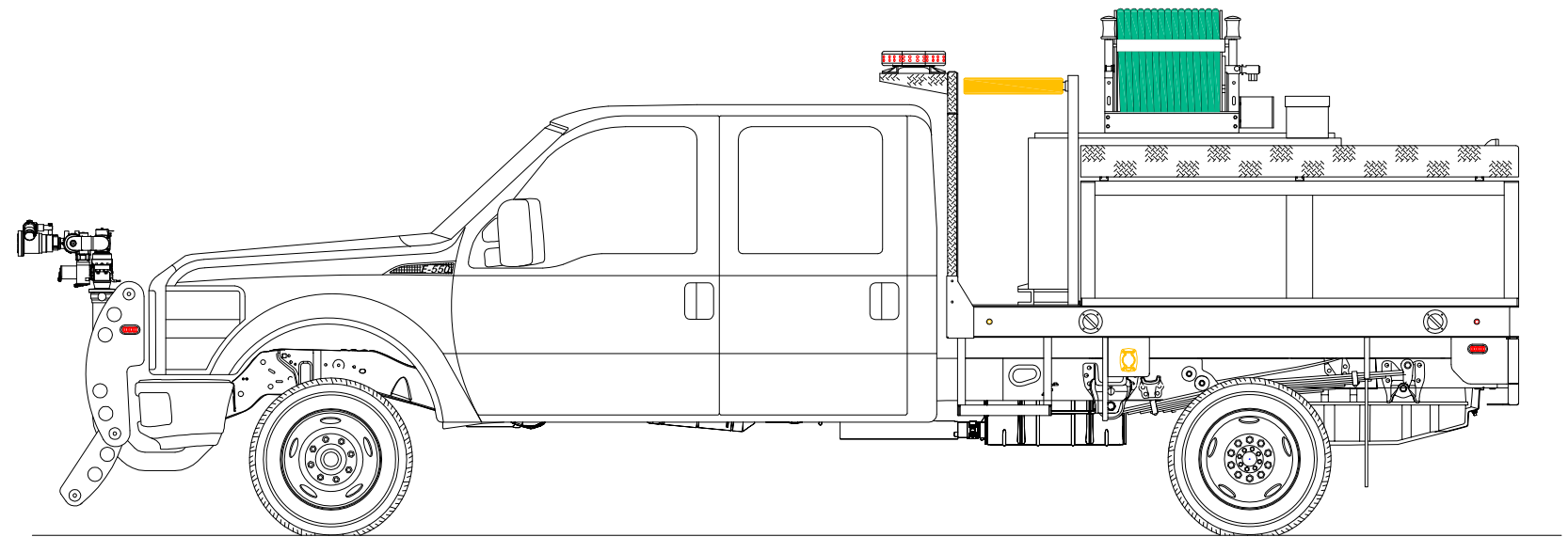
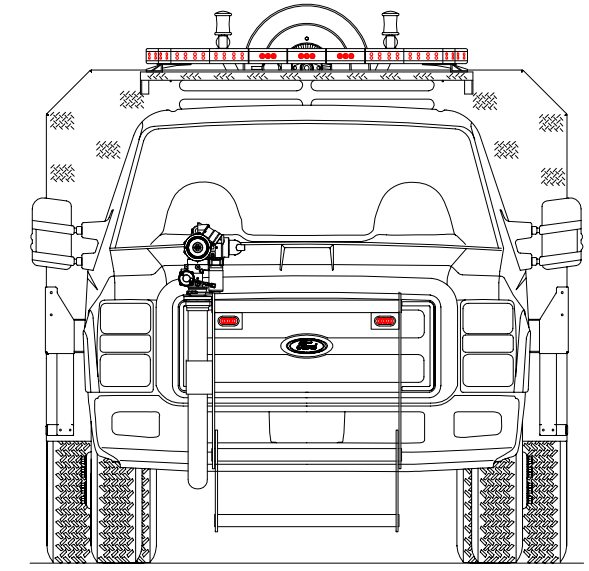
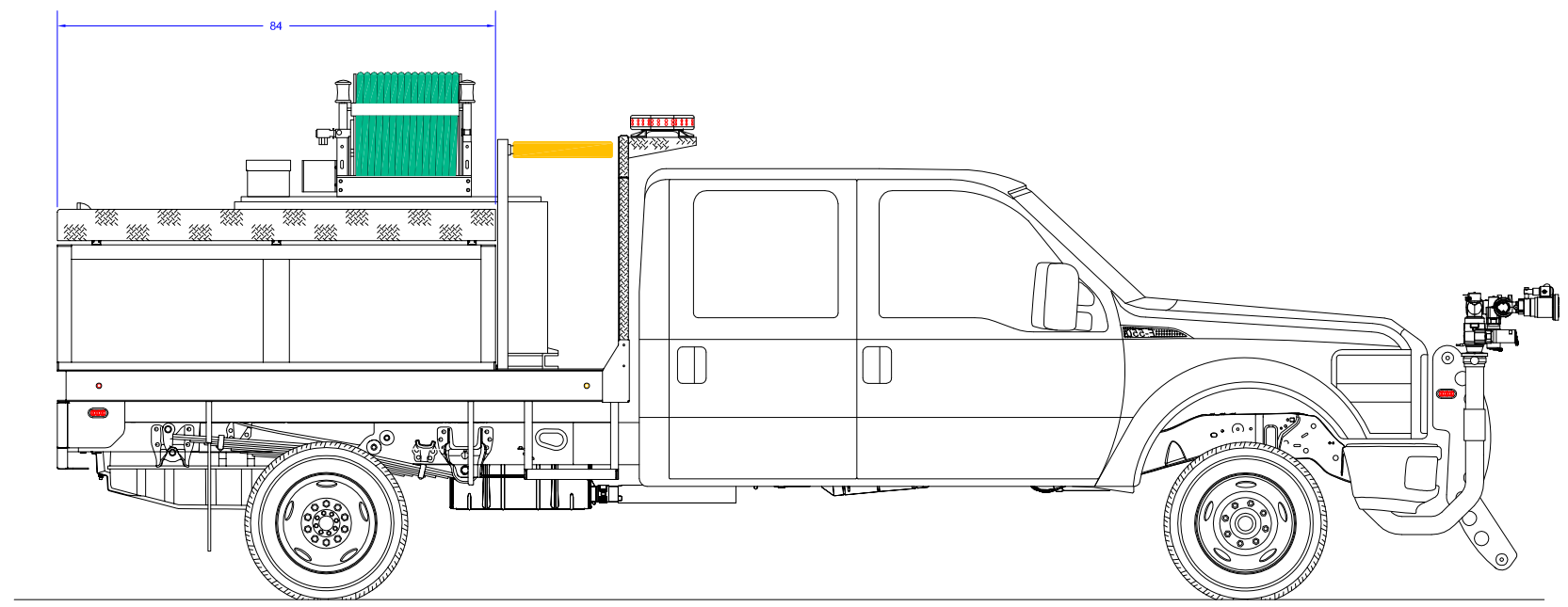

REVISION HISTORY			
REV	DESCRIPTION	DATE	DWN

<b>Pump Info:</b>		<b>Apparatus Type:</b> Brush Truck	
Control Location:	Rear	Chassis:	Ford 4-Door
Pump Drive:		Tank Capacity:	300
Pump Make:	Skid - Gas	Material:	Aluminum
Pump Model:			
Pump GPM:			

COMPARTMENT DIMENSIONS	
COMP #	DOOR OPENING SIZES
L1 & L2	36" WIDE X 19" HIGH X 17" DEEP
R1 & R2	36" WIDE X 19" HIGH X 17" DEEP

UNLESS OTHERWISE SPECIFIED DIMENSIONS ARE IN INCHES TOLERANCES ARE NOT CUMULATIVE  
 DECIMAL ± 0.062 ANGULAR ± 0.5°  
 FRACTIONAL ± 1/16 METRIC ± 1.6 mm

The copyright of this drawing and design and the right of reproduction there is vested in and belongs to Alexis Fire Equipment Co.

DRAWN	M.TINKHAM	3/2/16
MATERIAL		

**Alexis FIRE EQUIPMENT CO.**  
 P.O. BOX 549, ALEXIS, ILLINOIS 61412

**BRUSH TRUCK**  
 ALEXIS FIRE EQUIPMENT  
 ALEXIS, ILLINOIS

SIZE	SCALE	DWG NO
D	3/4" = 1'	SK-C25
CONTRACT #	SK821	SHEET 2 OF 2